



SHENZHEN TOPDOLEY TECHNOLOGY CO., LTD



Your Reliable Partner of Motion Control Parts

ABOUT US



A Professional and Reliable Motion Control Manufacturer

Shenzhen Topdoley Technology Co., Ltd is a high-tech enterprise with core servo drive technology. Adhering to the corporate spirit of integrity, pragmatism, hard work and innovation. As a national high-tech enterprise, we dedicated to the R&D, production and sales of DC servo motors, servo drives/system, gearboxes, AGV wheels and other core components.

Topdoley provides automation industry servo supporting solutions, especially has a leading position in electronic servo systems for mobile robots.

Topdoley always keep in mind that we must make continuous efforts to bring our customers greater and greater value through good quality products and services at the most reasonable prices.



DC Servo System Introduction

The DC servo system adopts advanced servo control technology, with a high-performance processor to provide users with a cost-effective servo control solution, pursuing the closest functionality and performance to the application while ensuring stability and reliability.

- High-speed Capabilities
 - Compact size design
 - powerful and efficient
 - Support RS-485, Modbus, CAN/CANopen, Ethercat protocols and equipped with advanced technology.
-





JD Series servo system

- CSP multi-axis synchronization can be realized to meet the needs of special scenes.
- Using advanced noise suppression technology, the product has low noise, low heat, and high efficiency.
- Approximate zero workpiece trajectory tracking.
- The constant torque output is stable, the speed is controllable and the position is accurate.

JD-3A Servo Driver Technical Parameters

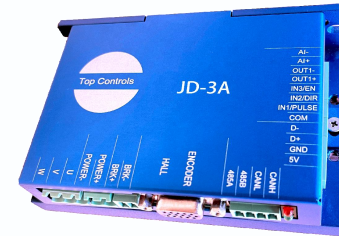

Model	JD-3A
Input Voltage Range	18-60VDC
Continuous Current	3A
Peak Current	9A
Motors Supported	Three phase BLDC motor with encoder
Feedback Supported	Incremental Encoder, Absolute encoder(NRZ)
Control Interface	Pulse, Analog, RS485
Inputs & Outputs	Analogy Input: AI, -10V~+10V Digital Input: 3 DI, 12-30V Digital Output: 1 DO, 12-30V
Protection	Overspeed / undervoltage/overcurrent/overload/encoder error/over position,etc.
Ambient Temperature	.-20~50°C (non-freezing), The average load should not exceed 80% of the rated, Above 40°C, please reduce the amount of use, the maximum temperature is 60°C(normal temperature version no load operation)
Working Environment Humidity	Less than 90% RH (no Dewing)

Dimension

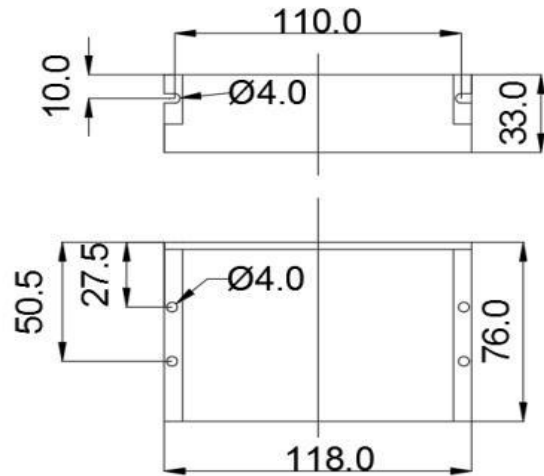

Drive Wiring

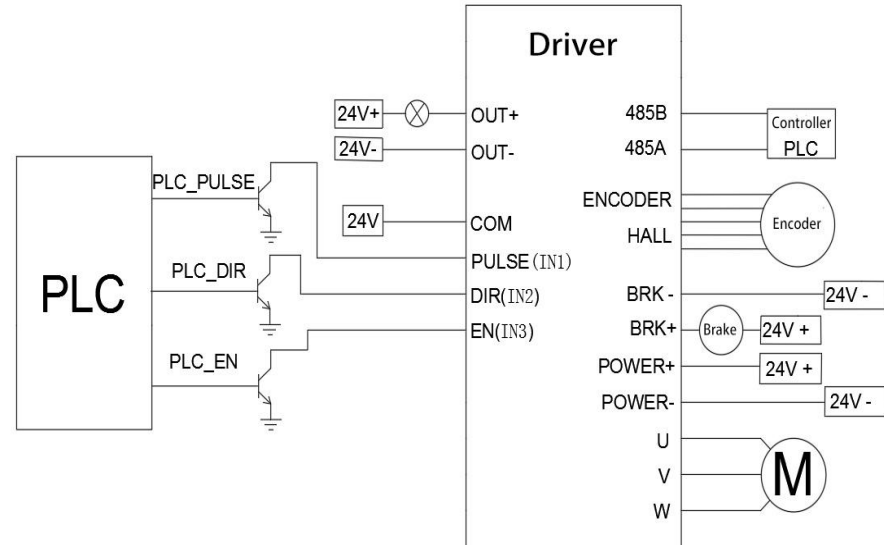

Order Information

Model	Voltage (V)	Peak Current (A)	Adaptable Motor	Encoder Option	Control Interface	Brake
JD-3A	18-60	9A	<ul style="list-style-type: none"> DC Servo Motor Brushless Motor with encoder 	<ul style="list-style-type: none"> Incremental Encoder Absolute encoder 	<ul style="list-style-type: none"> RS485 Pulse Analog 	<ul style="list-style-type: none"> No brake with brake

JD-6A Servo Driver Technical Parameters

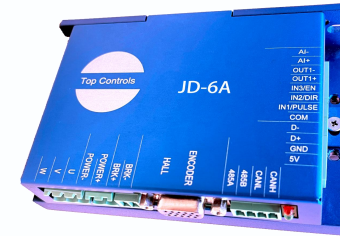

Model	JD-6A
Input Voltage Range	18-60VDC
Continuous Current	6A
Peak Current	18A
Motors Supported	Three phase BLDC motor with encoder
Feedback Supported	Incremental Encoder, Absolute encoder(NRZ)
Control Interface	Pulse, Analog, RS485, Canopen
Inputs & Outputs	Analogy Input: AI, -10V~+10V Digital Input: 3 DI, 12-30V Digital Output: 1 DO, 12-30V
Protection	Overspeed / undervoltage/overcurrent/overload/encoder error/over position, etc.
Ambient Temperature	.-20~50°C (non-freezing), The average load should not exceed 80% of the rated, Above 40°C, please reduce the amount of use, the maximum temperature is 60°C(normal temperature version no load operation)
Working Environment Humidity	Less than 90% RH (no Dewing)

Dimension

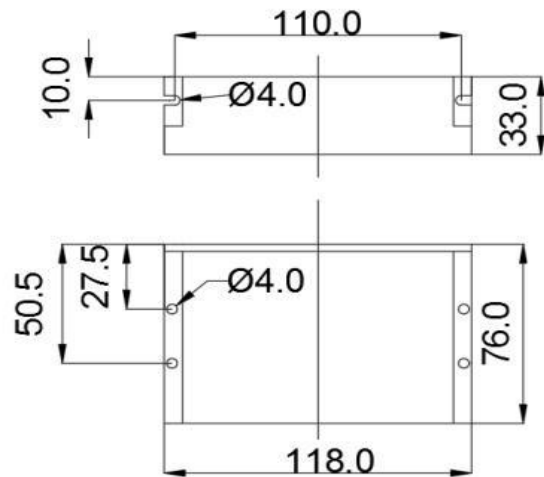

Drive Wiring

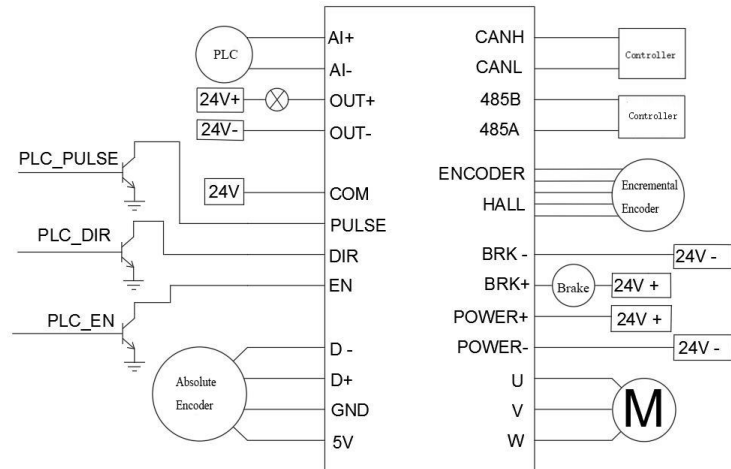

Order Information

Model	Voltage (V)	Peak Current (A)	Adaptable Motor	Encoder Option	Control Interface	Brake
JD-6A	18-60	18A	<ul style="list-style-type: none"> DC Servo motor Brushless motor with encoder 	<ul style="list-style-type: none"> Incremental encoder Absolute encoder 	<ul style="list-style-type: none"> RS485 Pulse Analog Canopen 	<ul style="list-style-type: none"> No brake With brake

JD-15A Servo Driver Technical Parameters



Model	JD-15A
Input Voltage Range	18-60VDC
Continuous Current	15A
Peak Current	30A
Motors Supported	Three phase BLDC motor with encoder
Feedback Supported	Incremental Encoder, Absolute encoder(NRZ)
Control Interface	Pulse, Analog, RS485, Canopen
Inputs & Outputs	Analogy Input: AI, -10V~+10V Digital Input: 3 DI, 12-30V Digital Output: 1 DO, 12-30V
Protection	Overspeed / undervoltage/overcurrent/overload/encoder error/over position, etc.
Ambient Temperature	.-20~50°C (non-freezing), The average load should not exceed 80% of the rated, Above 40°C, please reduce the amount of use, the maximum temperature is 60°C(normal temperature version no load operation)
Working Environment Humidity	Less than 90% RH (no Dewing)

Dimension

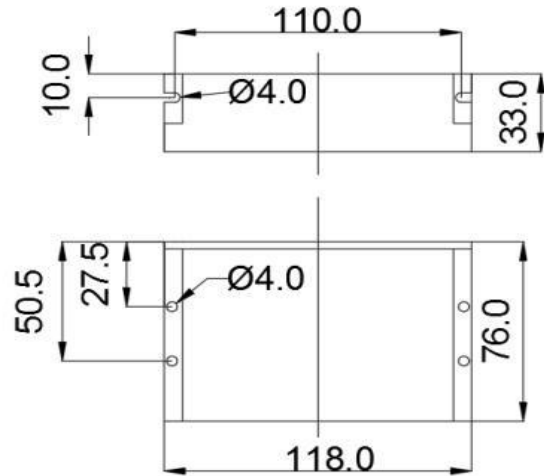

Drive Wiring

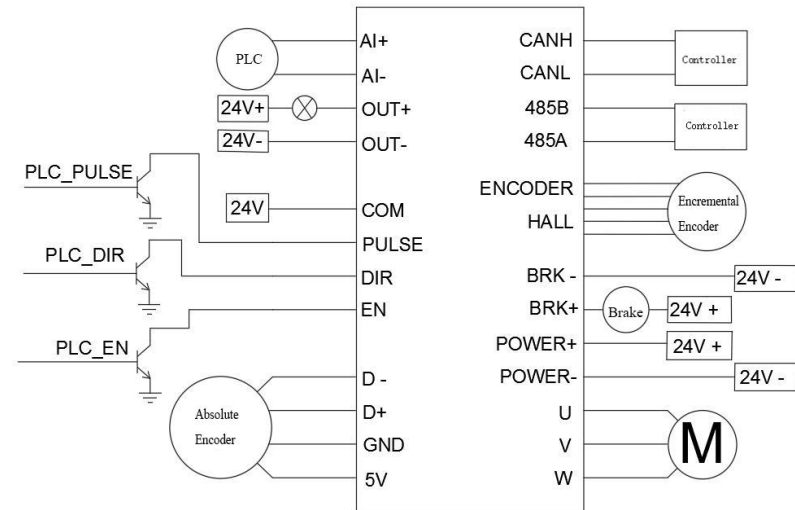

Order Information

Model	Voltage (V)	Peak Current (A)	Adaptable Motor	Encoder Option	Control Interface	Brake
JD-15	18-60	30A	<ul style="list-style-type: none"> DC Servo Motor Brushless Motor with encoder 	<ul style="list-style-type: none"> Incremental encoder Absolute encoder 	<ul style="list-style-type: none"> RS485 Pulse Analog Canopen 	<ul style="list-style-type: none"> No brake with brake



TD Series Servo system

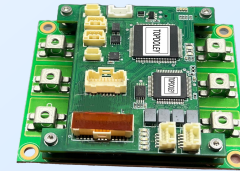

TD 40A Servo Driver Technical Parameters

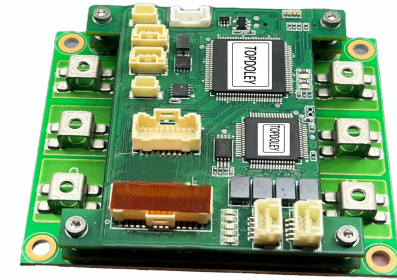

Model	TD-40A
Input Voltage Range	18-60VDC
Continuous Current	40A
Peak Current	80A
Motors Supported	Three phase BLDC motor with encoder
Feedback Supported	Incremental Encoder, Absolute encoder(NRZ)
Control Interface	Pulse, Analog, RS485, Canopen, Ethercat
Inputs & Outputs	Analogy Input: AI, -10V~+10V Digital Input: 3 DI, 12-30V Digital Output: 1 DO, 12-30V
Protection	Overspeed / undervoltage/overcurrent/overload/encoder error/over position,etc.
Ambient Temperature	.-20~50°C (non-freezing), The average load should not exceed 80% of the rated, Above 40°C, please reduce the amount of use, the maximum temperature is 60°C(normal temperature version no load operation)
Working Environment Humidity	Less then 90% RH (no Dewing)

TD 50A Servo Driver Technical Parameters

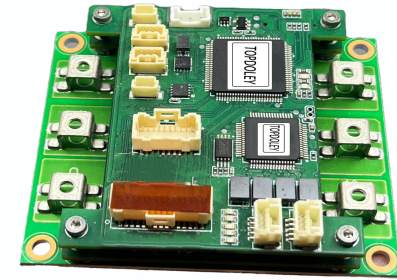

Model	TD-50A
Input Voltage Range	18-60VDC
Continuous Current	50A
Peak Current	100A
Motors Supported	Three phase BLDC motor with encoder
Feedback Supported	Incremental Encoder, Absolute encoder(NRZ)
Control Interface	Pulse, Analog, RS485, Canopen, Ethercat
Inputs & Outputs	Analogy Input: AI, -10V~+10V Digital Input: 3 DI, 12-30V Digital Output: 1 DO, 12-30V
Protection	Overspeed / undervoltage/overcurrent/overload/encoder error/over position,etc.
Ambient Temperature	.-20~50°C (non-freezing), The average load should not exceed 80% of the rated, Above 40°C, please reduce the amount of use, the maximum temperature is 60°C(normal temperature version no load operation)
Working Environment Humidity	Less than 90% RH (no Dewing)

DC Servo Motor Introduction

Our Servomotors have a higher torque density, they are together with our drive to serve the purpose of automation, which in turn is used in industrial processes to reduce cost and errors while improving accuracy and efficiency. The Servomotor runs stably and has low noise and vibration.

They are made for high performance applications where the most power in the smallest package size is critical.

Various encoder feedback options are available for our servomotors, based on the needs of the applications.

Options include incremental encoders, with a variety of resolutions, and absolute encoders, both single-turn and multi-turn.

High-torque brushless servo motors. SM series motors come in 40, 60, and 80 mm frame sizes with 10,000-count incremental commutating encoders and IP65 ratings on the motor body.



Name Ruling

SM	60	J	750	-48	30	O	I	A	5
①	②	③	④	⑤	⑥	⑦	⑧	⑨	⑩

①	Product mode	SM	HM	⑥	Maximum speed (*100rpm)	15=1500 rpm	30=3000rpm
②	Frame size	60=60(mm)	80=80(mm)	⑦	Encoder type	M=Magnetic encoder	O=Optical encoder
③	Interior series	J	Z	⑧	Encoder	I=Incremental 2500	A=Absolute encoder
④	Rated power	400	600	⑨	Brake	A=No brake	B=With brake
⑤	Rated voltage	24	48	⑩	Pole pairs	4	5

40 SERIES DC SERVO MOTORS

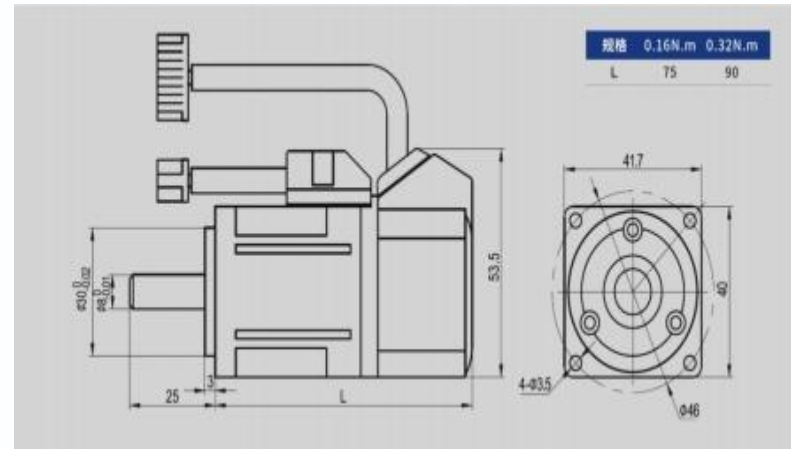

Motor Model	SM40X0050-24300IA4	SM40X0100-24300IA4	SM40X0050-48300IA4	SM40X0100-48300IA4
Rated Power(W)	50	100	50	100
Rated Voltage(V)	24	24	48	48
Rated Current(A)	2.6	5.2	1.1	2.5
Rated Speed(RPM)	3000	3000	3000	3000
Rated Torque(N.m)	0.16	0.32	0.16	0.32
Voltage Constant (V/1000r/min)	4	4	9.2	8.2
Torque Coefficient(N.m/A)	0.067	0.061	0.145	0.128
Rotor Inertia(KG.M2)	0.025 x 10 ⁻⁴	0.051 x 10 ⁻⁴	0.025 x 10 ⁻⁴	0.051 x 10 ⁻⁴
Line-line Resistance(Q)	1.39	0.49	6.75	2.2
Line-line Inductance(mH)	1.52	0.71	7.5	3
Electrical Time-constant(ms)	1.09	1.45	1.11	1.36
Encoder Line Number(PPR)	2500	2500	2500	
Insulation Class	ClassB(130°C)	ClassB(130°C)	ClassB(130°C)	
Safety Class	IP65	IP65	IP65	
Environment	Temperature: -20°C ~ +50°C Humidity Below 90%rh No Dewing			

60 SERIES DC SERVO MOTORS

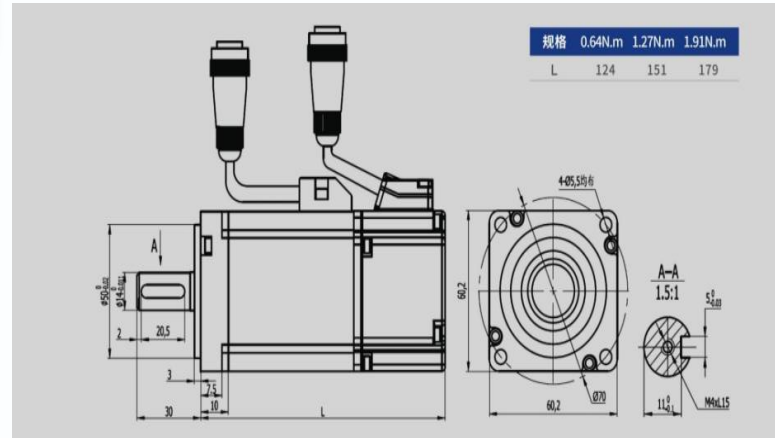

Motor Model	SM60X0200-4830IA4	SM60X0400-4830IA4	SM60X0600-4830IA4	SM60X0200-2430IA4
Rated Power(W)	200	400	600	200
Rated Voltage(V)	48	48	48	24
Rated Current(A)	5.7	11	14.5	12
Rated Speed(RPM)	3000	3000	3000	3000
Rated Torque(N.m)	0.64	1.27	1.91	0.637
Voltage Constant (V/1000r/min)	8	8	8.5	4
Torque Coefficient(N.m/A)	0.112	0.115	0.132	0.053
Rotor Inertia(KG.M2)	0.175x10-4	0.29x10-4	0.39 x 10-4	0.175x 10-4
Line-line Resistance(Q)	0.3	0.15	0.138	0.11
Line-line Inductance(mH)	1.378	0.708	0.64	0.42
Electrical Time-constant(ms)	4.59	4.72	4.64	3.81
Encoder Line Number(PPR)	2500	2500	2500	2500
Insulation Class	ClassB(130°C)	ClassB(130°C)	ClassB(130°C)	ClassF
Safety Class	IP65			
Environment	Temperature: -20°C ~ +50°C Humidity Below 90%rh No Dewing			

80 SERIES DC SERVO MOTORS

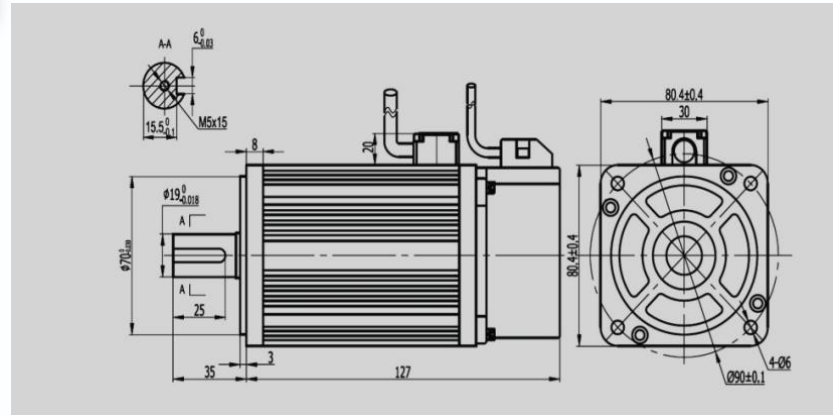

Motor Model	SM80X0400-24300IA4	SM80X0750-24300IA4	SM80X0400-48300IA4	SM80X0750-48300IA4	SM80X1000-48250IA4
Rated Power(W)	400	750	400	750	1000
Rated Voltage(V)	24	24	48	48	48
Rated Current(A)	20	34	10.9	19.5	27
Rated Speed(RPM)	3000	3000	3000	3000	2500
Rated Torque(N.m)	1.27	2.39	1.27	2.39	4
Voltage Constant (V/1000r/min)	4.5	4.6	7.2	7.4	9.2
Torque Coefficient(N.m/A)	0.063	0.07	0.115	0.123	0.148
Rotor Inertia(KG.M2)	1.05x10 ⁻⁴	1.82 x 10 ⁻⁴	1.05x 10 ⁻⁴	1.82 x 10 ⁻⁴	2.97x 10 ⁻⁴
Line-line Resistance(Q)	0.06	0.028	0.15	0.066	0.053
Line-line Inductance(mH)	0.093	0.054	0.27	0.151	0.131
Electrical Time-constant(ms)	1.55	1.93	1.8	2.29	2.47
Encoder Line Number(PPR)	2500	2500	2500	2500	2500
Insulation Class	ClassF	ClassF	ClassB(130°C)		
Safety Class	IP65				
Environment	Temperature: -20°C ~ +50°C Humidity Below 90%rh No Dewing				

AGV Drive Wheel Introduction

The AGV wheel is a critical component of Automated Guided Vehicles (AGVs), responsible for supporting, driving, and ensuring smooth movement. Our AGV wheels are designed with high-performance materials and advanced manufacturing techniques to ensure durability and stability. They are widely used in smart logistics, factory automation, and warehouse robotics.

- High Load Capacity – Made from high-strength materials such as polyurethane, rubber, or nylon to meet various load requirements.
- Low Noise Operation – Optimized wheel structure reduces noise levels, making it ideal for quiet environments.
- Wear-Resistant & Impact-Resistant – High-quality materials ensure excellent durability for long-term operation.
- Precision Driving – Integrated with precision bearings and motor-driven designs for accurate and efficient movement.
- Adaptability to Complex Surfaces – Designed with anti-slip and shock-absorbing features, making them suitable for smooth floors, metal surfaces, epoxy-coated floors, and other environments.



95 Series AGV Wheel Parameters

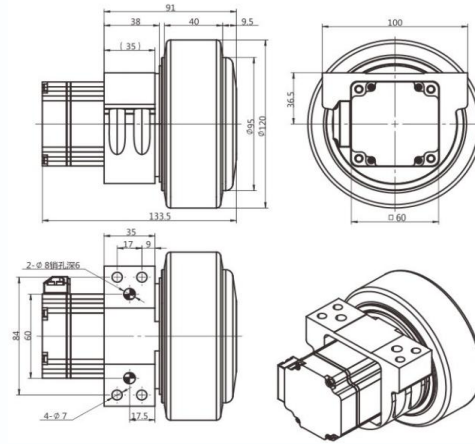
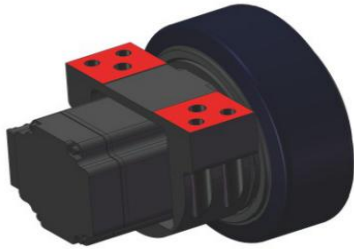

AGV Wheel	TD-AGVS-95-400-120	TD-AGVS-95-400-140
Power(W)	400	400
Rate Voltage(V)	48	48
Rate Current(A)	11.95	10.6
Rate Speed (r/min)	3000	3000
Rate Torque (N.m)	1.27	1.27
Wheel Diameter(mm)	120	120
Reducer Ratio	16/20/25/28/35/40/50/70	

125 Series AGV Wheel Parameters

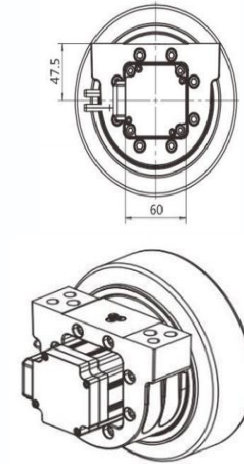
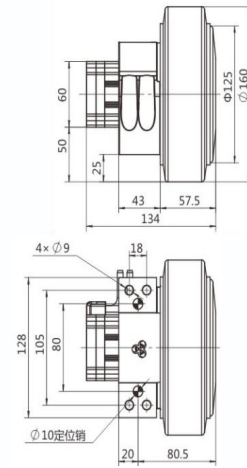
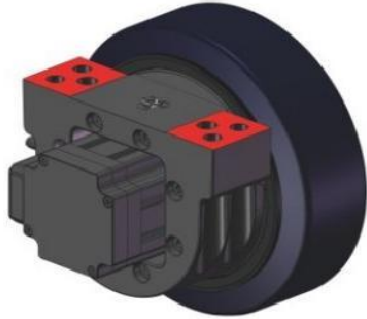

AGV Wheel	TD-AGVS-125-400-150	TD-AGVS-125-400-160	TD-AGVS-125-750-150	TD-AGVS-125-750-160
Power(W)	400	400	750	750
Rate Voltage(V)	48	48	48	48
Rate Current(A)	11.95	11.95	22.4	22.4
Rate Speed (r/min)	3000	3000	3000	3000
Rate Torque (N.m)	1.27	1.27	2.39	2.39
Wheel Diameter(mm)	125	125	125	125
Reducer Ratio	16/20/25/28/35/40/50/70			

150 Series AGV Wheel Parameters

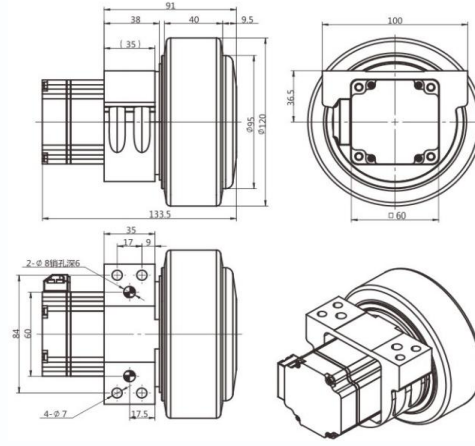

AGV Wheel	TD-AGVS-150-400-180	TD-AGVS-150-400-200	TD-AGVS-150-750-180	TD-AGVS-150-750-200
Power(W)	400	400	750	750
Rate Voltage(V)	48	48	48	48
Rate Current(A)	11.95	11.95	22.4	22.4
Rate Speed (r/min)	3000	3000	3000	3000
Rate Torque (N.m)	1.27	1.27	2.39	2.39
Wheel Diameter(mm)	150	150	150	150
Reducer Ratio	16/20/25/28/35/40/50/70			

165 Series AGV Wheel Parameters

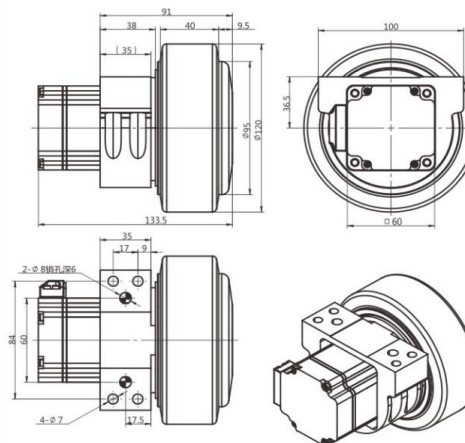

AGV Wheel	TD-AGVS-165-1500A-220	TD-AGVS-165-1500A-250
Power(W)	1500	1500
Rate Voltage(V)	48	48
Rate Current(A)	39	39
Rate Speed (r/min)	3000	3000
Rate Torque (N.m)	4.77	4.77
Wheel Diameter(mm)	220	220
Reducer Ratio	16/20/25/28/35/40/50/70	

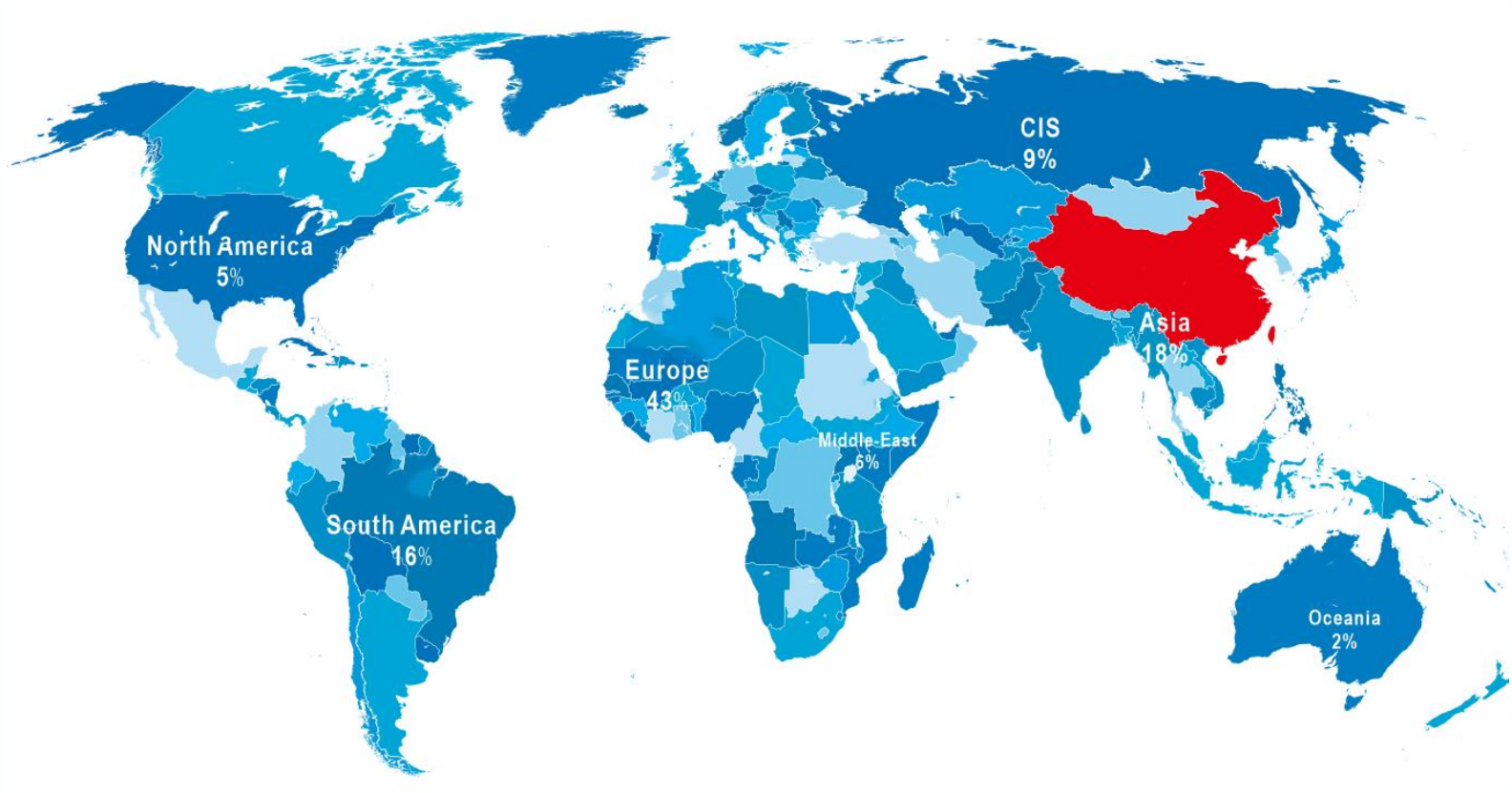

SHENZHEN TOPDOLEY TECHNOLOGY CO., LTD

Email: info@topdoley.com

Web: www.topdoley.com

Add: No. 2, Madi Street, Liuyue Community, Henggang Street, Longgang District, Shenzhen

Your Reliable Partner of Motion
Control Parts