

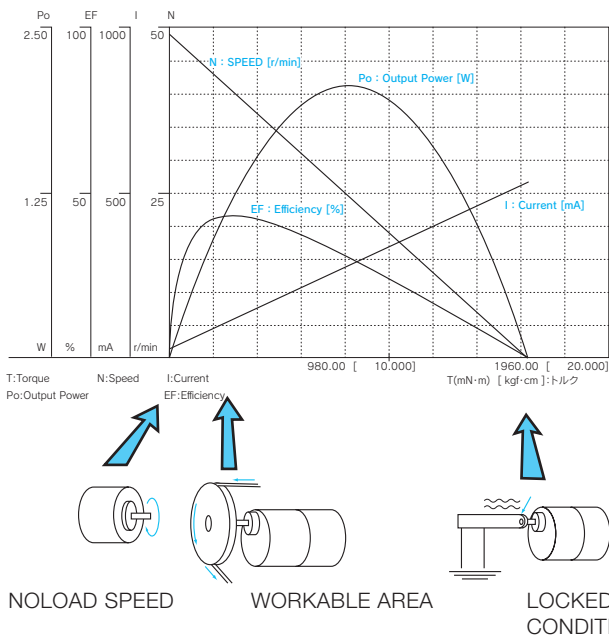

DC
GEARED
MOTOR

SPEED AND LOAD CHARACTERISTICS



The relationship between torque vs speed and current is linear as shown left ; as the load on a motor increases, speed will decrease.

The graph pictured here represents the characteristics of a typical motor.

As long as the motor is used in the area of high efficiency (as represented by the shaded area) long life and good performance can be expected. However, using the motor outside this range will result in high temperature rises and deterioration of motor parts.

If voltage in continuous applied to a motor in a locked rotor condition, the motor will heat up and fail in a relatively short time.

Therefore it is important that there is some form of protection against high temperature rises.

A motor's basic rating point is slightly lower than its maximum efficiency point.

Load torque can be determined by measuring the current drawn when the motor is attached to a machine whose actual load value is known.

We will select the most suitable motor for your application after receiving your information.

AS APPLIED VOLTAGE WILL BE CHANGED

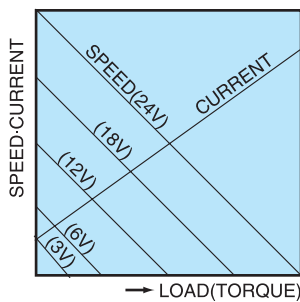

As shown left, if the applied voltage is changed, no load speed and starting torque also change in proportion to the voltage.

Speed characteristics at a given voltage are parallel to those at other voltages.

Thus, a DC motor can be used at a voltage lower than the rated voltage.

But, below 1000 rpm, the speed becomes unstable, and the motor will not run smoothly.

CHARACTERISTICS AND RATED PERFORMANCE OF A GEARED MOTOR

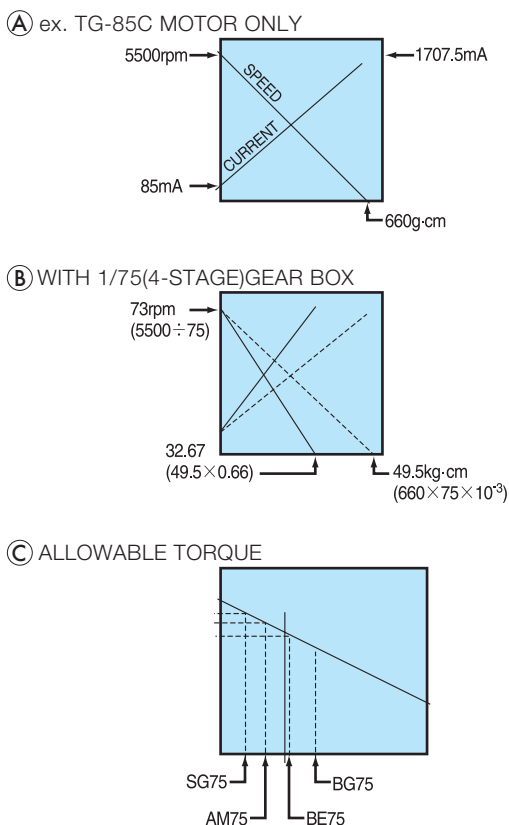

Speed reduction by means of a gear box results in increased torque.

The reduction/increase is determined by the gear ratio and efficiency of the gear box.

Over-all efficiency depends on the number of reduction stages : one average is 90% per stage. Therefore : a two stage reduction gives $90 \times 90 = 81\%$; 3 stages will be 72.9% and a 4-stage reduction 66%.

The above mechanical loss effects the stall torque as shown left.

Stall torque of a geared motor can be calculated using the following formula : —Motor stall torque × gear ratio × efficiency.

The output loading on a gear box must never exceed the manufactures "specified rated torque" as this will cause premature gear failure.

It is particularly important to observe this at slow output speeds when the calculated output torque exceeds the specified rated torque.

GEAR BOX CONSTRUCTION AND FEATURES

INTERMITTENT DUTY

(Suitable for less than 2sec.)
on & long enough off time)

STANDARD TYPE

GL, SS, LG, SG, AGD, WM, VG, VM, BG

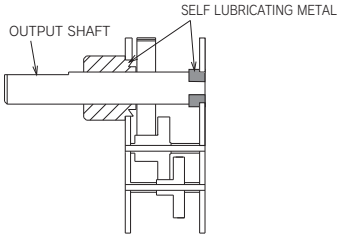
STANDARD GEAR MECHANISM
Other than the output gear, the gears rotate around a shaft that is fixed to the plate.

HEAVY LOAD

—self lubricating metal type.

SM, AMD, BE, BM, JM



—ballbearing at all stages

AP, BM

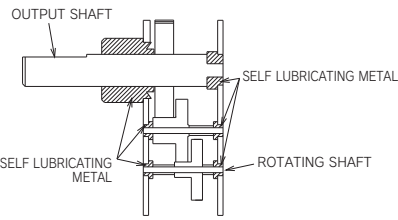
NON-LUBRICATED METAL BEARING GEAR MECHANISM
All gears, including the output gear, are attached to the shaft and supported by non-lubricated metal bearings. This type of mechanism is suitable for medium load applications and continuous duty cycle operation.

LOW COST VERSION—Plastic or sintered metal. **EU, RU, VG, LG**

COMPACT SIZE TYPE

—Planetary

GU, EU, RU, FU, KU, SU

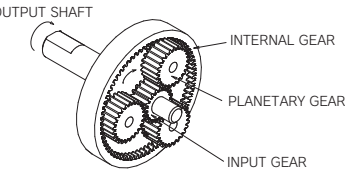
PLANETARY GEAR MECHANISM
A heavy duty type gear mechanism using 3 mating gears to transmit torque to the output shaft. This type of mechanism is suitable for limited space applications.

Protection against overload and locked rotor

When the rotor is locked and voltage is applied to the motor terminals, the temperature of the motor windings will rise and eventually short-circuit.

The time until a short-circuit condition appears differs per motor type.

It is recommended that the motor is protected against such an overload by means of a fuse, current limiter or mechanical protection.

Protection against RFI/EMI caused by PWM control

An internally installed suppressor reduces electrical commutation noise caused by the brushes. Depending on the requirements, extra precautions sometimes are recommended such as an external capacitor, or filter circuit.

When driven in PWM at certain Frequencies it may occur that a motor does not start due to the combination of driving frequency and internally fitted capacitive noise suppressor.

Precautions for instantaneous reversing and dynamic braking

When the power supply to the motor is switched off, it is advisable to allow the motor to stop rotating before reversing the supply polarity.

Failure to do this will result in a very high instantaneous current.

It is possible to stop the motor within a few revolutions by applying a short-circuit across the motor terminals immediately after the motor is switched off. This method is very effective but may shorten brush life.

Vertical mounting with shaft up

In some cases when a motor-gear is mounted in this position, traces of lubrication oil can contaminate the brushes and commutator thus shortening brush life or causing a short-circuit. Please contact us when vertical mounting is required.

Speed detection and control

A number of models can be provided with a magnetic or optical encoder.

Please contact us for detailed information and assistance.

NEW PRODUCT

TG-55LA

BUILT-IN DRIVE CIRCUIT, COMPACT, BRUSHLESS MOTOR.



Single motor specification

TYPE	RATED VOLTAGE (V)	NO-LOAD SPEED (r/min)	NO-LOAD CURRENT (mA)	TORQUE		RATED SPEED (r/min)	RATED CURRENT (mA)	DIRECTION OF ROTATION	WEIGHT (g)
				(mN · m)	(gf · cm)				
TG-55LA	24	3700	120	19.6	200	2400	420	BOTH DIRECTIONS	165

Single motor outline

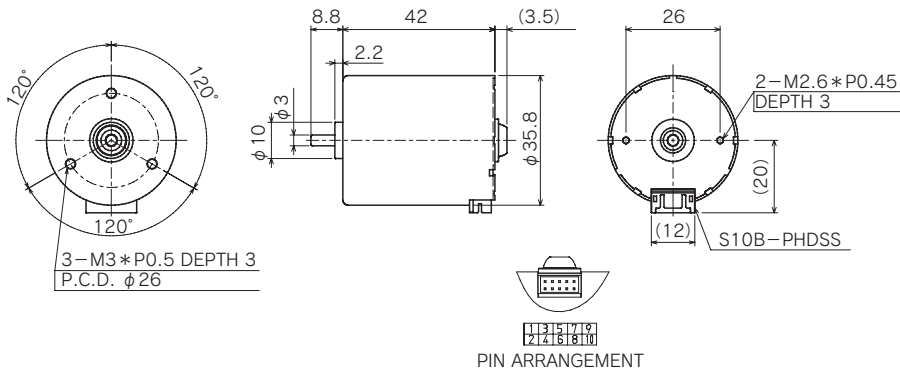

Reference Connection Diagram

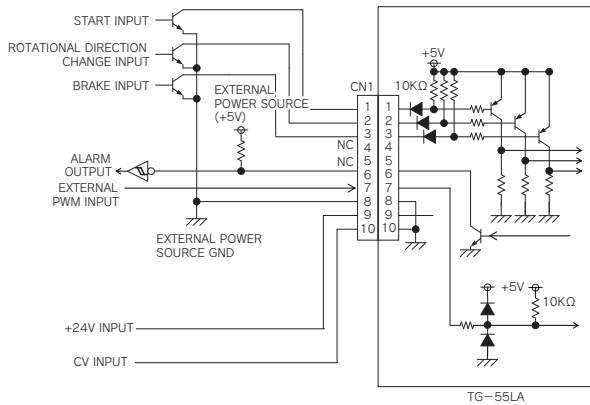

Input/Output Signal

PIN No.	SIGNAL NAME	CONTENT	
1	START INPUT	"H" : STOP "L" : ROTATIONAL MOVEMENT	
2	ROTATIONAL DIRECTION CHANGE INPUT*	"H" : CW ROTATION "L" : CCW ROTATION	"H" : OPEN "L" : 0 ~ 0.7 V INPUT CURRENT: 3 mA MAX.
3	BRAKE INPUT	SELECT STOP METHOD AT ROTATIONAL MOVEMENT. "H" : BRAKE STOP "L" : BRAKE RELEASE	
4	UNUSED		
5	UNUSED		
6	ALARM OUTPUT	OUTPUT TRANSISTOR OFF ON DETECTING OVERHEAT, MOTOR LOCK OR OVERCURRENT.	OPEN COLLECTOR OUTPUT MAX. APPLIED VOLTAGE: 30 V MAX. CURRENT: 10 mA SATURATION VOLTAGE AT ON: 0.8 V MAX.
7	PWM INPUT	INPUT VOLTAGE: WITHIN 0 ~ 5 V FREQUENCY RANGE: 20 ~ 27 kHz	"H" FIXED: ROTATION STOP "L" FIXED: MAX. DUTY OPERATION (ROTATIONAL SPEED CHANGES SINCE CLOSED LOOP CONTROL IS NOT DONE.)
8	GND	GROUND FOR CONTROL INPUT SIGNAL (SAME POTENTIAL AS PIN 10)	
9	POWER INPUT	+24 V INPUT	
10	POWER INPUT	0 V INPUT (SAME POTENTIAL AS PIN 8)	

* Rotational direction is one with single motor. Refer to the specification of each geared motor for the rotational direction of the geared motor output shaft.

TG-87 (1.7W) $\phi 16$, COMPACT DESIGN.

APPLICATION ATM / MONEY COUNTING MACHINE / CARD READER / PRINTER / SECURITY CAMERA / CASSETTE LOADING / MEDICAL EQUIPMENT etc.

GU

TG-87A
TG-87B

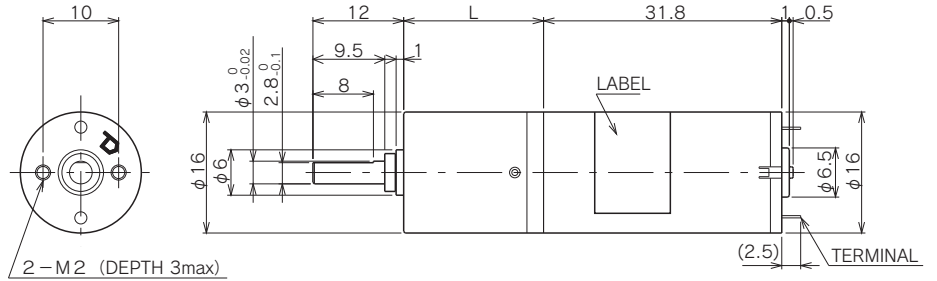

Allowable torque-speed characteristics GU

MODEL	GEAR RATIO	1	1	1	1	1	1	1	1	1	1	1	1	1	
		3.5	4.9	12.5	17.3	24.1	44	61.2	85.1	118	155	216	300	418	581
TG-87A-GU (12V)	SPEED (r/min)	3336	2352	939	697	485	267	189	136	97.3	74.4	53.2	38.8	28.2	20.9
	TORQUE (mN·m)	2.9	4.9	9.8	9.8	19.6	29.4	49	68.6	98	107.8	156.8	196	245	245
	TORQUE (kgf·cm)	0.03	0.05	0.1	0.1	0.2	0.3	0.5	0.7	1	1.1	1.6	2	2.5	2.5
TG-87B-GU (24V)	SPEED (r/min)	3336	2352	939	697	485	267	189	136	97.3	74.4	53.2	38.8	28.2	20.9
	TORQUE (mN·m)	2.9	4.9	9.8	9.8	19.6	29.4	49	68.6	98	107.8	156.8	196	245	245
	TORQUE (kgf·cm)	0.03	0.05	0.1	0.1	0.2	0.3	0.5	0.7	1	1.1	1.6	2	2.5	2.5

GU

GEAR RATIO	L (mm)	STAGE	TORQUE		WEIGHT (g)
			(mN·m)	(kgf·cm)	
1/3.5 ~ 1/4.9	15.1	1	49	0.5	18
1/12.5 ~ 1/24.1	18.5	2	98	1	21
1/44 ~ 1/118	22	3	147	1.5	24
1/155	25.5	4	147	1.5	28
1/216 ~ 1/581	25.5	4	245	2.5	28

TG-01 (0.4 ~ 0.8W) $\phi 21.3$, COMPACT DESIGN.

APPLICATION ATM / MONEY COUNTING MACHINE / CARD READER / PRINTER / BLINDS / SECURITY CAMERA / CASSETTE LOADING / FINISHER / MEDICAL EQUIPMENT etc.

EU

TG-01F
TG-01G
TG-01H

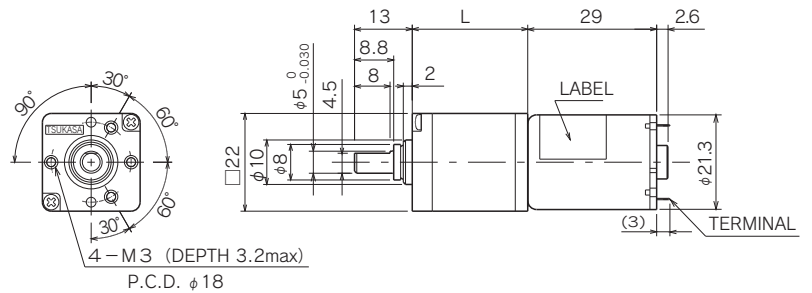

Allowable torque-speed characteristics EU

MODEL	GEAR RATIO	1	1	1	1	1	1	1	1	1	
		12.1	17.6	20.6	25.5	42.1	61.2	71.7	88.7	104	129
TG-01F-EU (24V)	SPEED (r/min)	316	225	194	149	94.1	62.6	53	43	36.7	29.5
	TORQUE (mN·m)	8.82	9.8	9.8	19.6	19.6	39.2	49	58.8	68.6	88.2
	TORQUE (kgf·cm)	0.09	0.1	0.1	0.2	0.2	0.4	0.5	0.6	0.7	0.9
TG-01G-EU (24V)	SPEED (r/min)	609	425	365	289	177	121	103	83	70.9	57.1
	TORQUE (mN·m)	8.82	8.82	9.8	19.6	19.6	39.2	49	58.8	68.6	88.2
	TORQUE (kgf·cm)	0.09	0.1	0.1	0.2	0.2	0.4	0.5	0.6	0.7	0.9
TG-01H-EU (12V)	SPEED (r/min)	600	420	361	285	175	119	101	81.8	69.9	56.3
	TORQUE (mN·m)	8.82	9.8	9.8	19.6	19.6	39.2	49	58.8	68.6	88.2
	TORQUE (kgf·cm)	0.09	0.1	0.1	0.2	0.2	0.4	0.5	0.6	0.7	0.9

EU

GEAR RATIO	L (mm)	STAGE	TORQUE		WEIGHT (g)
			(mN·m)	(kgf·cm)	
1/12.1 ~ 1/25.5	21	2	98	1	34
1/42.1 ~ 1/129	26	3	147	1.5	36

FU

TG-01F
TG-01G
TG-01H

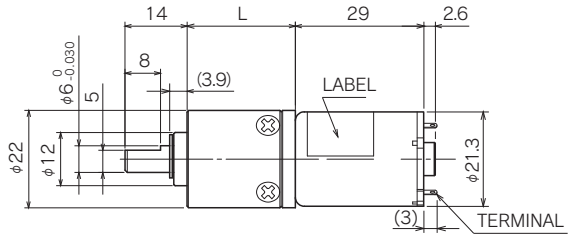
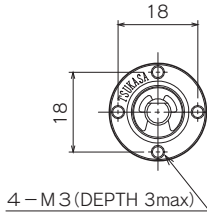

Allowable torque-speed characteristics FU

MODEL	GEAR RATIO	FU													
		1/4	1/4.7	1/16	1/19	1/23	1/64	1/76	1/90	1/107	1/256	1/304	1/361	1/429	1/509
TG-01F-FU (24V)	SPEED (r/min)	1026	855	258	220	187	63.7	53.4	44.9	37.9	15.8	13.3	11.3	9.5	8
	TORQUE (mN·m)	2.94	3.92	9.8	9.8	9.8	39.2	49	58.8	68.6	147	176.4	196	245	294
	TORQUE (kgf·cm)	0.03	0.04	0.1	0.1	0.1	0.4	0.5	0.6	0.7	1.5	1.8	2	2.5	3
TG-01G-FU (24V)	SPEED (r/min)	1919	1604	481	409	347	119	100	84.3	71.1	29.7	25	21.2	17.8	14.9
	TORQUE (mN·m)	2.94	3.92	9.8	9.8	9.8	39.2	49	58.8	68.6	147	176.4	196	245	294
	TORQUE (kgf·cm)	0.03	0.04	0.1	0.1	0.1	0.4	0.5	0.6	0.7	1.5	1.8	2	2.5	3
TG-01H-FU (12V)	SPEED (r/min)	1924	1608	482	410	348	120	100	84.5	71.3	29.8	25.1	21.2	17.8	15
	TORQUE (mN·m)	2.94	3.92	9.8	9.8	9.8	39.2	49	58.8	68.6	147	176	196	245	294
	TORQUE (kgf·cm)	0.03	0.04	0.1	0.1	0.1	0.4	0.5	0.6	0.7	1.5	1.8	2	2.5	3

FU

GEAR RATIO	L (mm)	STAGE	TORQUE		WEIGHT (g)
			(mN·m)	(kgf·cm)	
1/4 ~ 1/4.7	19.5	1	49	0.5	41
1/16 ~ 1/23	24.5	2	98	1	49
1/64 ~ 1/107	29.5	3	196	2	57
1/256 ~ 1/509	34.5	4	294	3	66

RU

TG-01F
TG-01G
TG-01H

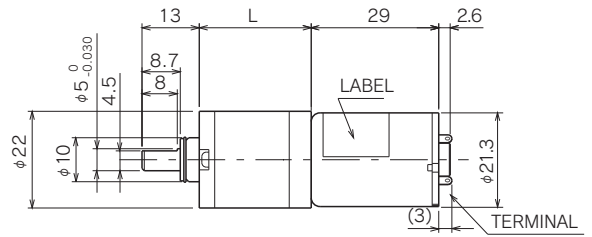
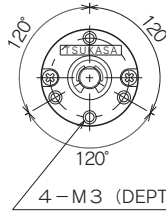

Allowable torque-speed characteristics RU

MODEL	GEAR RATIO	RU													
		3.7	5	13.4	18.3	25	49.3	67.2	91.7	125	181	246	336	458	625
TG-01F-RU (24V)	SPEED (r/min)	1108	815	301	227	170	82.6	60.9	44.1	33.2	23.3	17.4	12.9	9.5	7
	TORQUE (mN·m)	2.94	3.92	9.8	9.8	9.8	29.4	39.2	58.8	58.8	58.8	58.8	58.8	58.8	58.8
	TORQUE (kgf·cm)	0.03	0.04	0.1	0.1	0.1	0.3	0.4	0.6	0.6	0.6	0.6	0.6	0.6	0.6
TG-01G-RU (24V)	SPEED (r/min)	2079	1528	566	423	314	155	114	82.9	62	43.3	32.1	23.7	17.5	12.9
	TORQUE (mN·m)	2.94	3.92	9.8	9.8	9.8	29.4	39.2	58.8	58.8	58.8	58.8	58.8	58.8	58.8
	TORQUE (kgf·cm)	0.03	0.04	0.1	0.1	0.1	0.3	0.4	0.6	0.6	0.6	0.6	0.6	0.6	0.6
TG-01H-RU (12V)	SPEED (r/min)	2084	1532	567	424	315	155	114	83.1	62.1	43.4	32.2	23.8	17.5	12.9
	TORQUE (mN·m)	2.94	3.92	9.8	9.8	9.8	29.4	39.2	58.8	58.8	58.8	58.8	58.8	58.8	58.8
	TORQUE (kgf·cm)	0.03	0.04	0.1	0.1	0.1	0.3	0.4	0.6	0.6	0.6	0.6	0.6	0.6	0.6

RU

GEAR RATIO	L (mm)	STAGE	TORQUE		WEIGHT (g)
			(mN·m)	(kgf·cm)	
1/3.7 ~ 1/5	15.5	1	29.4	0.3	24
1/13.4 ~ 1/25	20.5	2	58.8	0.6	27
1/49.3 ~ 1/125	25.5	3	58.8	0.6	30
1/181 ~ 1/625	30.5	4	58.8	0.6	33

TG-201

(1.1 ~ 2.0W) $\phi 21.3$, HIGH POWER, COMPACT DESIGN, SLIM TYPE.

APPLICATION

ATM / MONEY COUNTING MACHINE / CARD READER / PRINTER / BLINDS / SECURITY CAMERA / CASSETTE LOADING etc.

EU

TG-201A
TG-201B

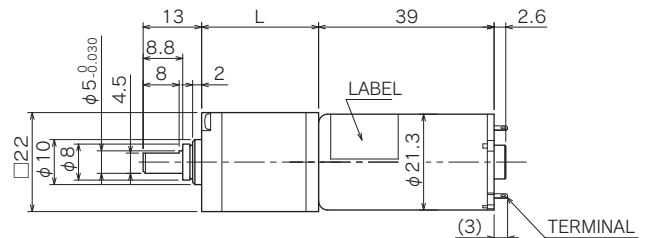
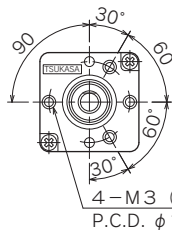

Allowable torque-speed characteristics EU

MODEL	GEAR RATIO	EU									
		1/12.1	1/17.6	1/20.6	1/25.5	1/42.1	1/61.2	1/71.7	1/88.7	1/104	1/129
TG-201A-EU (24V)	SPEED (r/min)	358	246	205	165	101	69.7	59.3	47.8	41.9	34.8
	TORQUE (mN·m)	19.6	29.4	39.2	49	68.6	98	117.6	147	147	147
	TORQUE (kgf·cm)	0.2	0.3	0.4	0.5	0.7	1	1.2	1.5	1.5	1.5
TG-201B-EU (24V)	SPEED (r/min)	541	359	313	246	151	103	87.5	72.7	63.2	52
	TORQUE (mN·m)	19.6	39.2	39.2	68.8	78.4	117.6	147	147	147	147
	TORQUE (kgf·cm)	0.2	0.4	0.4	0.6	0.8	1.2	1.5	1.5	1.5	1.5

EU

GEAR RATIO	L (mm)	STAGE	TORQUE		WEIGHT (g)
			(mN·m)	(kgf·cm)	
1/12.1 ~ 1/25.5	21	2	98	1	34
1/42.1 ~ 1/129	26	3	147	1.5	36

FU

TG-201A
TG-201B

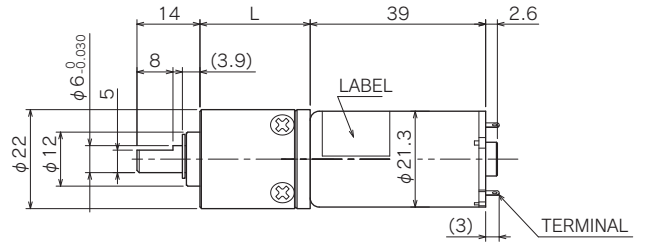
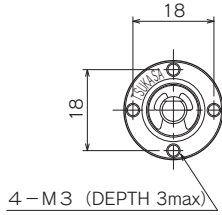

Allowable torque-speed characteristics

FU

MODEL	GEAR RATIO	FU													
		1/4	1/4.7	1/16	1/19	1/23	1/64	1/76	1/90	1/107	1/256	1/304	1/361	1/429	1/509
TG-201A-FU (24V)	SPEED (r/min)	1072	895	265	230	190	66.9	56.2	46.9	39.4	17.2	14.8	12.7	10.8	9.2
	TORQUE (mN·m)	7.84	9.8	29.4	29.4	39.2	98	117.6	147	176.4	294	294	294	294	294
	TORQUE (kgf·cm)	0.08	0.1	0.3	0.3	0.4	1	1.2	1.5	1.8	3	3	3	3	3
TG-201B-FU (24V)	SPEED (r/min)	1581	1362	404	335	280	98.1	83	69.8	59.3	25.8	22.1	18.8	16	13.6
	TORQUE (mN·m)	9.8	9.8	29.4	39.2	49	127.4	147	176.4	196	294	294	294	294	294
	TORQUE (kgf·cm)	0.1	0.1	0.3	0.4	0.5	1.3	1.5	1.8	2	3	3	3	3	3

FU

GEAR RATIO	L (mm)	STAGE	TORQUE		WEIGHT (g)
			(mN·m)	(kgf·cm)	
1/4 ~ 1/4.7	19.5	1	49	0.5	41
1/16 ~ 1/23	24.5	2	98	1	49
1/64 ~ 1/107	29.5	3	196	2	57
1/256 ~ 1/509	34.5	4	294	3	66

TG-47

(0.9 ~ 3.6W) 5-SLOT, BESTSELLER, ENCODER CAN BE MOUNTED.

APPLICATION

ATM / MONEY COUNTING MACHINE / CARD READER / PRINTER / BLINDS / SECURITY CAMERA / CASSETTE LOADING / MEDICAL EQUIPMENT etc.

EU

TG-47E
TG-47F
TG-47G

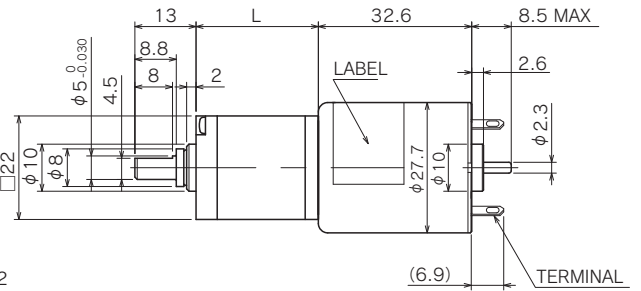
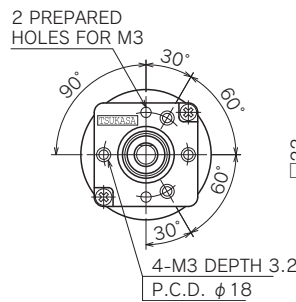

Allowable torque-speed characteristics

EU

MODEL	GEAR RATIO	EU											
		1/12.1	1/17.6	1/20.6	1/25.5	1/42.1	1/61.2	1/71.7	1/88.7	1/104	1/129		
TG-47E-EU (24V)	SPEED (r/min)	380	256	212	170	105	71.4	60.4	49	41.9	34.4		
	TORQUE (mN·m)	9.8	19.6	29.4	39.2	49	78.4	98	117.6	137.2	147		
	TORQUE (kgf·cm)	0.1	0.2	0.3	0.4	0.5	0.8	1	1.2	1.4	1.5		
TG-47F-EU (24V)	SPEED (r/min)	569	376	328	258	158	108	91.6	76.3	66.4	54.7		
	TORQUE (mN·m)	19.6	39.2	39.2	58.8	78.4	117.6	147	147	147	147		
	TORQUE (kgf·cm)	0.2	0.4	0.4	0.6	0.8	1.2	1.5	1.5	1.5	1.5		
TG-47G-EU (12V)	SPEED (r/min)	382	257	214	171	105	71.8	60.8	49.3	42.1	34.6		
	TORQUE (mN·m)	9.8	19.6	29.4	39.2	49	78.4	98	117.6	137.2	147		
	TORQUE (kgf·cm)	0.1	0.2	0.3	0.4	0.5	0.8	1	1.2	1.4	1.5		

EU

GEAR RATIO	L (mm)	STAGE	TORQUE		WEIGHT (g)
			(mN·m)	(kgf·cm)	
1/12.1 ~ 1/25.5	21	2	98	1	34
1/42.1 ~ 1/129	26	3	147	1.5	36

FU

TG-47E
TG-47F
TG-47G

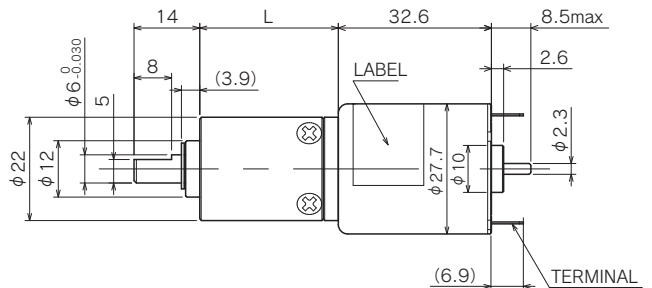
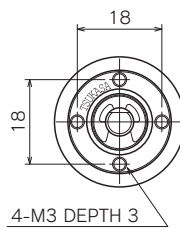

Allowable torque-speed characteristics

FU

MODEL	GEAR RATIO	FU													
		1/4	1/4.7	1/16	1/19	1/23	1/64	1/76	1/90	1/107	1/256	1/304	1/361	1/429	1/509
TG-47E-FU (24V)	SPEED (r/min)	1084	917	278	238	196	68.4	57.3	48.2	40.6	17	14.6	12.5	10.7	9.1
	TORQUE (mN·m)	6.86	7.84	19.6	19.6	29.4	78.4	98	117.6	137.2	294	294	294	294	294
	TORQUE (kgf·cm)	0.07	0.08	0.2	0.2	0.3	0.8	1	1.2	1.4	3	3	3	3	3
TG-47F-FU (24V)	SPEED (r/min)	1656	1429	424	351	293	103	86.9	73	62.2	27.1	23.2	19.8	16.9	14.4
	TORQUE (mN·m)	9.8	9.8	29.4	39.2	49	127.4	147	176.4	196	294	294	294	294	294
	TORQUE (kgf·cm)	0.1	0.1	0.3	0.4	0.5	1.3	1.5	1.8	2	3	3	3	3	3
TG-47G-FU (24V)	SPEED (r/min)	2267	1937	559	468	394	137	115	99.1	84.9	36.5	31	26.3	22.3	18.9
	TORQUE (mN·m)	9.8	9.8	39.2	49	58.8	166.6	196	196	196	294	294	294	294	294
	TORQUE (kgf·cm)	0.1	0.1	0.4	0.5	0.6	1.7	2	2	2	3	3	3	3	3
TG-47G-FU (12V)	SPEED (r/min)	1091	923	280	239	197	68.9	57.6	48.5	40.9	17.1	14.7	12.6	10.7	9.1
	TORQUE (mN·m)	6.86	7.84	19.6	19.6	29.4	78.4	98	117.6	137.2	294	294	294	294	294
	TORQUE (kgf·cm)	0.07	0.08	0.2	0.2	0.3	0.8	1	1.2	1.4	3	3	3	3	3

FU

GEAR RATIO	L (mm)	STAGE	TORQUE		WEIGHT (g)
			(mN·m)	(kgf·cm)	
1/4 ~ 1/4.7	19.5	1	49	0.5	41
1/16 ~ 1/23	24.5	2	98	1	49
1/64 ~ 1/107	29.5	3	196	2	57
1/256 ~ 1/509	34.5	4	294	3	66

LG

TG-47E
TG-47F
TG-47G

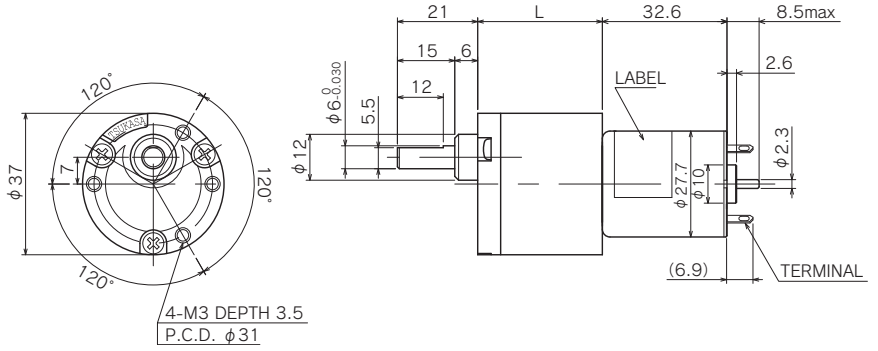

Allowable torque-speed characteristics

LG

MODEL	GEAR RATIO	1															
		6	9	13	16	20	29	36	44	66	80	100	148	181	224		
TG-47E-LG (24V)	SPEED (r/min)	753	516	355	278	229	152	124	99.8	66.7	54.3	43.9	29.4	24	19.8		
	TORQUE (mN·m)	8.82	9.8	9.8	19.6	19.6	29.4	39.2	49	68.6	88.2	107.8	147	186.2	196		
	TORQUE (kgf·cm)	0.09	0.1	0.1	0.2	0.2	0.3	0.4	0.5	0.7	0.9	1.1	1.5	1.9	2		
TG-47F-LG (24V)	SPEED (r/min)	1191	759	730	423	338	229	184	150	101	82	66.4	45.4	37.2	30.1		
	TORQUE (mN·m)	9.8	19.6	19.6	29.4	39.2	49	68.6	78.4	107.8	137.2	166.6	196	245	294		
	TORQUE (kgf·cm)	0.1	0.2	0.2	0.3	0.4	0.5	0.7	0.8	1.1	1.4	1.7	2	2.5	3		
TG-47G-LG (24V)	SPEED (r/min)	1605	1038	690	560	451	302	246	199	133	109	89.4	59.2	49.7	40.9		
	TORQUE (mN·m)	9.8	19.6	29.4	39.2	49	68.6	88.2	107.8	147	176.4	196	294	294	294		
	TORQUE (kgf·cm)	0.1	0.2	0.3	0.4	0.5	0.7	0.9	1.1	1.5	1.8	2	3	3	3		
TG-47G-LG (12V)	SPEED (r/min)	758	518	356	280	231	153	125	100	67.1	54.7	44.2	29.6	24.2	19.9		
	TORQUE (mN·m)	8.82	9.8	9.8	19.6	19.6	29.4	39.2	49	68.6	88.2	107.8	147	186.2	196		
	TORQUE (kgf·cm)	0.09	0.1	0.1	0.2	0.2	0.3	0.4	0.5	0.7	0.9	1.1	1.5	1.9	2		

LG

GEAR RATIO	L (mm)	STAGE	TORQUE		WEIGHT (g)
			(mN·m)	(kgf·cm)	
1/6, 1/9	25.7	2	49	0.5	69
1/13, 1/16, 1/20	25.7	3	98	1	73
1/29	29.2	4	98	1	77
1/36, 1/44	29.2	4	196	2	77
1/66, 1/80, 1/100	32.6	5	294	3	81
1/148, 1/181, 1/224	36.1	6	294	3	85

SG/SM

TG-47E
TG-47F
TG-47G

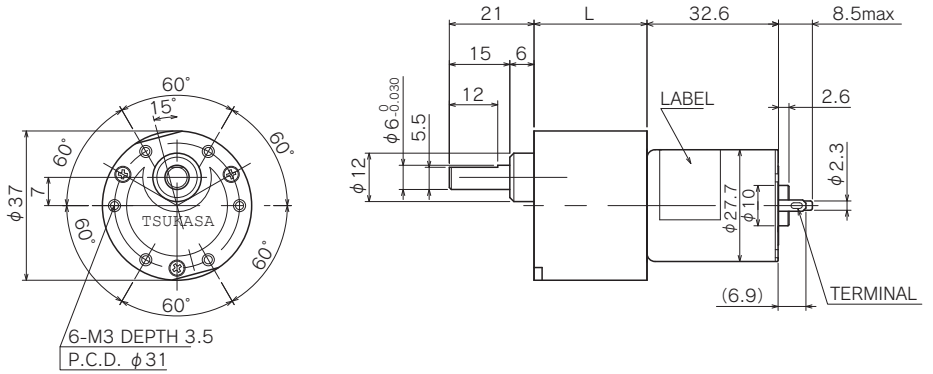

Allowable torque-speed characteristics

SG

SM

MODEL	GEAR RATIO	1																			
		5	10	15	18	25	30	36	50	60	75	100	120	150	200	250	300	500	750	1000	1500
TG-47E-SG (24V)	SPEED (r/min)	868	456	292	249	177	146	123	87.6	73.3	58.4	43.4	36.2	29	22.1	17.7	14.5	8.7	6	4.6	3.1
	TORQUE (mN·m)	7.84	9.8	19.6	19.6	29.4	39.2	39.2	58.8	68.6	88.2	127.4	137.2	166.6	196	245	343	490	588	588	588
	TORQUE (kgf·cm)	0.08	0.1	0.2	0.2	0.3	0.4	0.4	0.6	0.7	0.9	1.3	1.4	1.7	2	2.5	3.5	5	6	6	6
TG-47F-SG (24V)	SPEED (r/min)	1352	676	444	379	266	222	183	133	111	88	66	55.3	44.2	32.9	26.7	22.1	13.7	9.5	7.3	4.9
	TORQUE (mN·m)	9.8	19.6	29.4	29.4	49	58.8	68.6	88.2	107.8	137.2	186.2	196	245	343	392	490	588	588	588	588
	TORQUE (kgf·cm)	0.1	0.2	0.3	0.3	0.5	0.6	0.7	0.9	1.1	1.4	1.9	2	2.5	3.5	4	5	6	6	6	6
TG-47G-SG (24V)	SPEED (r/min)	1836	881	588	488	351	294	244	175	146	117	87.8	73.9	58.2	43.9	35.2	29.7	18.5	12.6	9.6	6.4
	TORQUE (mN·m)	9.8	29.4	39.2	49	68.6	78.4	88.2	127.4	147	186.2	245	245	343	441	539	588	588	588	588	588
	TORQUE (kgf·cm)	0.1	0.3	0.4	0.5	0.7	0.8	0.9	1.3	1.5	1.9	2.5	2.5	3.5	4.5	5.5	6	6	6	6	6
TG-47G-SG (12V)	SPEED (r/min)	874	458	294	250	179	147	124	88.2	73.7	58.8	43.7	36.4	29.2	22.2	17.8	14.6	8.8	6	4.6	3.1
	TORQUE (mN·m)	7.84	9.8	19.6	19.6	29.4	39.2	39.2	58.8	68.6	88.2	127.4	137.2	166.6	196	245	343	490	588	588	588
	TORQUE (kgf·cm)	0.08	0.1	0.2	0.2	0.3	0.4	0.4	0.6	0.7	0.9	1.3	1.4	1.7	2	2.5	3.5	5	6	6	6
TG-47E-SM (24V)	SPEED (r/min)	868	456	292	249	177	146	123	87.6	73.3	58.4	43.4	36.2	29	22.1	17.7	14.5	8.7	6	4.6	—
	TORQUE (mN·m)	7.84	9.8	19.6	19.6	29.4	39.2	39.2	58.8	68.6	88.2	127.4	137.2	166.6	196	245	343	490	588	588	—
	TORQUE (kgf·cm)	0.08	0.1	0.2	0.2	0.3	0.4	0.4	0.6	0.7	0.9	1.3	1.4	1.7	2	2.5	3.5	5	6	6	—
TG-47F-SM (24V)	SPEED (r/min)	1352	676	444	379	266	222	183	133	111	88	66	55.3	44.2	32.9	26.7	22.1	13.7	9.5	7.3	—
	TORQUE (mN·m)	9.8	19.6	29.4	29.4	49	58.8	68.6	88.2	107.8	137.2	186.2	196	245	343	392	490	588	588	588	—
	TORQUE (kgf·cm)	0.1	0.2	0.3	0.3	0.5	0.6	0.7	0.9	1.1	1.4	1.9	2	2.5	3.5	4	5	6	6	6	—
TG-47G-SM (24V)	SPEED (r/min)	1836	881	588	488	351	294	244	175	146	117	87.8	73.9	58.2	43.9	35.2	29.7	18.5	12.6	9.6	—
	TORQUE (mN·m)	9.8	29.4	39.2	49	68.6	78.4	88.2	127.4	147	186.2	245	245	343	441	539	588	588	588	588	—
	TORQUE (kgf·cm)	0.1	0.3	0.4	0.5	0.7	0.8	0.9	1.3	1.5	1.9	2.5	2.5	3.5	4.5	5.5	6	6	6	6	—
TG-47G-SM (12V)	SPEED (r/min)	874	458	294	250	179	147	124	88.2	73.7	58.8	43.7	36.4	29.2	22.2	17.8	14.6	8.8	6	4.6	—
	TORQUE (mN·m)	7.84	9.8	19.6	19.6	29.4	39.2	39.2	58.8	68.6	88.2	127.4	137.2	166.6	196	245	343	490	588	588	—
	TORQUE (kgf·cm)	0.08	0.1	0.2	0.2	0.3	0.4	0.4	0.6	0.7	0.9	1.3	1.4	1.7	2	2.5	3.5	5	6	6	—

SG

GEAR RATIO	L (mm)	STAGE	TORQUE		WEIGHT (g)
			(mN·m)	(kgf·cm)	
1/5 ~ 1/10	20.5	2	98	1	100
1/12.5 ~ 1/30	23	3	196	2	105
1/36 ~ 1/100	25.5	4	294	3	110
1/120 ~ 1/300	28	5	588	6	115
1/360 ~ 1/1000	30.5	6	588	6	120
1/1500 ~ 1/3000	33	7	588	6	125

SM

GEAR RATIO	L (mm)	STAGE	TORQUE		WEIGHT (g)
			(mN·m)	(kgf·cm)	
1/5 ~ 1/10	23	2	98	1	100
1/12.5 ~ 1/30	25.5	3	196	2	105
1/36 ~ 1/100	28	4	294	3	110
1/120 ~ 1/300	30.5	5	588	6	115
1/360 ~ 1/1000	33	6	588	6	120

AGD/AMD

TG-47E
TG-47F
TG-47G

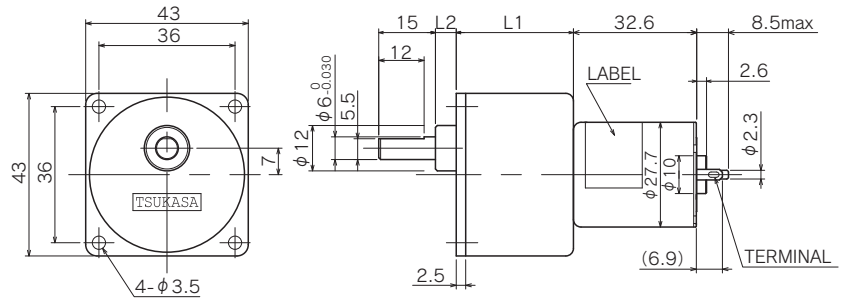

Allowable torque-speed characteristics AGD AMD

MODEL	GEAR RATIO	1																			
		5	10	15	18	25	30	36	50	60	75	100	120	150	200	250	300	500	750	1000	1500
TG-47E-AGD (24V)	SPEED (r/min)	868	456	292	249	177	146	123	87.6	73.3	58.4	43.4	36.2	29	22.1	17.7	14.5	8.7	6	4.6	3.1
	TORQUE (mN·m)	7.84	9.8	19.6	19.6	29.4	39.2	39.2	58.8	68.6	88.2	127.4	137.2	166.6	196	245	343	490	588	588	588
	TORQUE (kgf·cm)	0.08	0.1	0.2	0.2	0.3	0.4	0.4	0.6	0.7	0.9	1.3	1.4	1.7	2	2.5	3.5	5	6	6	6
TG-47F-AGD (24V)	SPEED (r/min)	1352	676	444	379	266	222	183	133	111	88	66	55.3	44.2	32.9	26.7	22.1	13.7	9.5	7.3	4.9
	TORQUE (mN·m)	9.8	19.6	29.4	29.4	49	58.8	68.6	88.2	107.8	137.2	186.2	196	245	343	392	490	588	588	588	588
	TORQUE (kgf·cm)	0.1	0.2	0.3	0.3	0.5	0.6	0.7	0.9	1.1	1.4	1.9	2	2.5	3.5	4	5	6	6	6	6
TG-47G-AGD (24V)	SPEED (r/min)	1836	881	588	488	351	294	244	175	146	117	87.8	73.9	58.2	43.9	35.2	29.7	18.5	12.6	9.6	6.4
	TORQUE (mN·m)	9.8	29.4	39.2	49	68.6	78.4	88.2	127.4	147	186.2	245	245	343	441	539	588	588	588	588	588
	TORQUE (kgf·cm)	0.1	0.3	0.4	0.5	0.7	0.8	0.9	1.3	1.5	1.9	2.5	2.5	3.5	4.5	5.5	6	6	6	6	6
TG-47G-AGD (12V)	SPEED (r/min)	874	458	294	250	179	147	124	88.2	73.7	58.8	43.7	36.4	29.2	22.2	17.8	14.6	8.8	6	4.6	3.1
	TORQUE (mN·m)	7.84	9.8	19.6	19.6	29.4	39.2	39.2	58.8	68.6	88.2	127.4	137.2	166.6	196	245	343	490	588	588	588
	TORQUE (kgf·cm)	0.08	0.1	0.2	0.2	0.3	0.4	0.4	0.6	0.7	0.9	1.3	1.4	1.7	2	2.5	3.5	5	6	6	6
TG-47G-AMD (24V)	SPEED (r/min)	1836	881	588	488	351	294	244	175	146	117	87.8	73.2	59	43.9	35.2	29.1	18.4	—	—	—
	TORQUE (mN·m)	9.8	29.4	39.2	49	68.6	78.4	98	127.4	147	186.2	245	294	343	441	539	686	686	—	—	—
	TORQUE (kgf·cm)	0.1	0.3	0.4	0.5	0.7	0.8	1	1.3	1.5	1.9	2.5	3	3.5	4.5	5.5	7	7	—	—	—

AGD

GEAR RATIO	L1 (mm)	L2 (mm)	STAGE	TORQUE		WEIGHT (g)
				(mN·m)	(kgf·cm)	
1/5 ~ 1/10	26	0.5	2	98	1	90
1/12.5 ~ 1/30	26	3	3	196	2	95
1/36 ~ 1/100	26	5.5	4	294	3	100
1/120 ~ 1/300	31	3	5	588	6	105
1/360 ~ 1/1000	31	5.5	6	588	6	110
1/1500 ~ 1/3000	31	8	7	588	6	115

AMD

GEAR RATIO	L1 (mm)	L2 (mm)	STAGE	TORQUE		WEIGHT (g)
				(mN·m)	(kgf·cm)	
1/5 ~ 1/10	26	4	2	98	1	110
1/12.5 ~ 1/18	26	6.5	3	343	3.5	115
1/25 ~ 1/36	26	6.5	3	392	4	115
1/50 ~ 1/75	31	4	4	490	5	115
1/90 ~ 1/150	31	4	4	686	7	115
1/180 ~ 1/500	31	6.5	5	686	7	120

VG

TG-47E
TG-47F
TG-47G

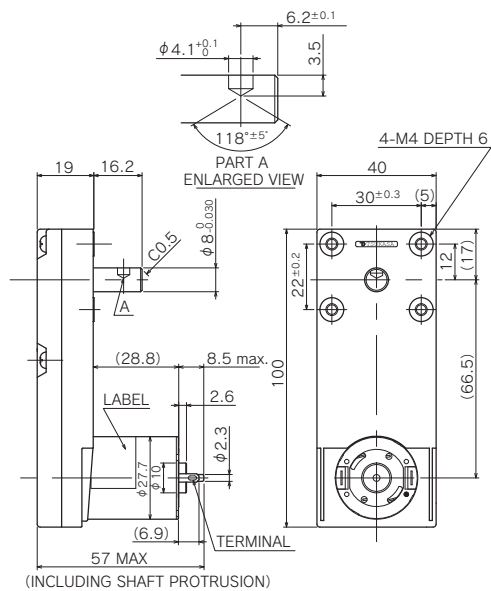

Allowable torque-speed characteristics VG

MODEL	GEAR RATIO	1				
		100	125	230	280	500
TG-47E-VG (24V)	SPEED (r/min)	43.3	35	19.2	15.8	8.5
	TORQUE (mN·m)	107.8	137.2	245	245	490
	TORQUE (kgf·cm)	1.1	1.4	2.5	2.5	5
TG-47F-VG (24V)	SPEED (r/min)	65.4	53.5	28.9	23.8	13.4
	TORQUE (mN·m)	166.6	196	392	392	588
	TORQUE (kgf·cm)	1.7	2	4	4	6
TG-47G-VG (24V)	SPEED (r/min)	88.1	71.4	38.7	31.4	18.1
	TORQUE (mN·m)	196	245	490	539	588
	TORQUE (kgf·cm)	2	2.5	5	5.5	6
TG-47G-VG (12V)	SPEED (r/min)	43.5	35.2	19.3	15.9	8.6
	TORQUE (mN·m)	107.8	137.2	245	245	490
	TORQUE (kgf·cm)	1.1	1.4	2.5	2.5	5

VG

GEAR RATIO	STAGE	TORQUE		WEIGHT (g)
		(mN·m)	(kgf·cm)	
1/100	5	392	4	115
1/125	5	392	4	115
1/230	5	588	6	115
1/280	6	588	6	120
1/500	6	588	6	120

TG-301

(1.2W) THIN TYPE, COMPACT AND LONG LIFE

APPLICATION

LASER PRINTER / COPIER / FINISHER / STAMPER / TICKETING DEVICE / STACKER /
 MONEY COUNTING MACHINE / BILL BINDING MACHINE / COIN HOPPER / VENDING MACHINE /
 BUS FARE BOX / ATM / GAMING MACHINE / SECURITY CAMERA / X-RAY MACHINE / SEWING MACHINE /
 VALVE / PRINTING PRESS / DISPENSING EQUIPMENT etc.

SS

TG-301A

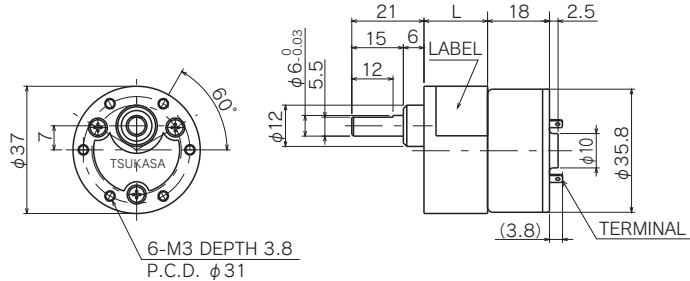

Allowable torque-speed characteristics

SS

MODEL	GEAR RATIO	1	1	1	1	1	1	1	1	1	1	1	1	1	1	1	1	1	1
		18	30	40	46	60	76	99	115	149	191	248	286	371	477	619			
TG-301A-SS (24V)	SPEED (r/min)	335	197	147	127	97.3	75.6	58.8	50.5	39.2	30.3	23.5	20.2	16.1	12.8	10.1			
	TORQUE (mN·m)	19.6	39.2	49	49	68.6	88.2	107.8	117.6	147	196	245	294	294	294	294			
	TORQUE (kgf·cm)	0.2	0.4	0.5	0.5	0.7	0.9	1.1	1.2	1.5	2	2.5	3	3	3	3			

SS

GEAR RATIO	L (mm)	STAGE	TORQUE		WEIGHT (g)
			(mN·m)	(kgf·cm)	
1/8 ~ 1/30	18.5	3	147	1.5	122
1/40	18.5	4	294	3	124
1/46 ~ 1/99	18.5	5	294	3	125
1/115 ~ 1/248	20.5	6	294	3	129
1/286 ~ 1/619	22.8	7	294	3	131

SG/SM

TG-301A

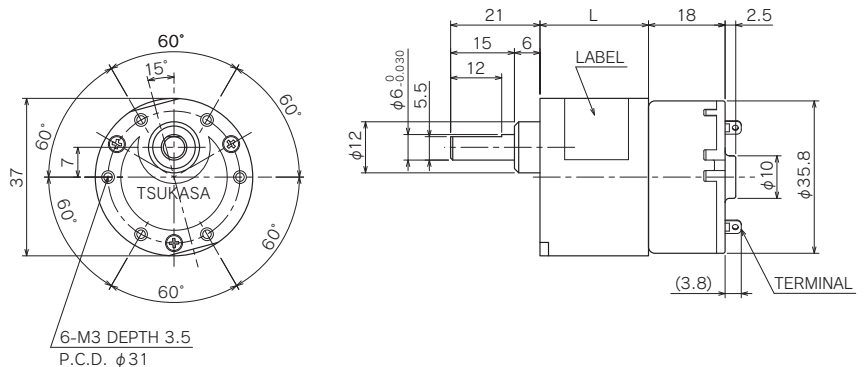

Allowable torque-speed characteristics

SG

SM

MODEL	GEAR RATIO	1	1	1	1	1	1	1	1	1	1	1	1	1	1	1	1	1	1	1	
		5	10	15	18	25	30	36	50	60	75	100	120	150	200	250	300	500	750	1000	1500
TG-301A-SG (24V)	SPEED (r/min)	1157	609	390	332	237	195	164	117	97.8	77.9	57.8	48.2	38.7	29.5	23.6	19.3	11.6	8	6.1	4.2
	TORQUE (mN·m)	7.8	9.8	19.6	19.6	29.4	39.2	39.2	58.8	68.6	88.2	127.4	137.2	166.6	196	245	343	490	588	588	588
	TORQUE (kgf·cm)	0.08	0.1	0.2	0.2	0.3	0.4	0.4	0.6	0.7	0.9	1.3	1.4	1.7	2	2.5	3.5	5	6	6	6
TG-301A-SM (24V)	SPEED (r/min)	1157	609	390	332	237	195	164	117	97.8	77.9	57.8	48.2	38.7	29.5	23.6	19.3	11.6	8	6.1	—
	TORQUE (mN·m)	7.8	9.8	19.6	19.6	29.4	39.2	39.2	58.8	68.6	88.2	127.4	137.2	166.6	196	245	343	490	588	588	—
	TORQUE (kgf·cm)	0.08	0.1	0.2	0.2	0.3	0.4	0.4	0.6	0.7	0.9	1.3	1.4	1.7	2	2.5	3.5	5	6	6	—

SG

GEAR RATIO	L (mm)	STAGE	TORQUE		WEIGHT (g)
			(mN·m)	(kgf·cm)	
1/5 ~ 1/10	20.5	2	98	1	100
1/12.5 ~ 1/30	23	3	196	2	105
1/36 ~ 1/100	25.5	4	294	3	110
1/120 ~ 1/300	28	5	588	6	115
1/360 ~ 1/1000	30.5	6	588	6	120
1/1500 ~ 1/3000	33	7	588	6	125

SM

GEAR RATIO	L (mm)	STAGE	TORQUE		WEIGHT (g)
			(mN·m)	(kgf·cm)	
1/5 ~ 1/10	23	2	98	1	100
1/12.5 ~ 1/30	25.5	3	196	2	105
1/36 ~ 1/100	28	4	294	3	110
1/120 ~ 1/300	30.5	5	588	6	115
1/360 ~ 1/1000	33	6	588	6	120

AGD/AMD

TG-301A

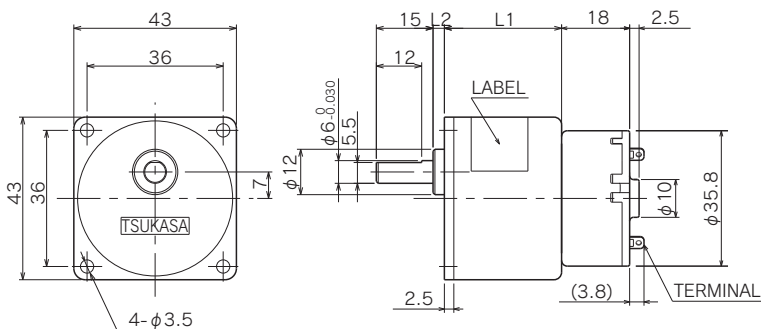

Allowable torque-speed characteristics AGD AMD

MODEL	GEAR RATIO	AGD																			
		5	10	15	18	25	30	36	50	60	75	100	120	150	200	250	300	500	750	1000	1500
TG-301A-AGD (24V)	SPEED (r/min)	1157	609	390	332	237	195	164	117	97.8	77.9	57.8	48.2	38.7	29.5	23.6	19.3	11.6	8	6.1	4.2
	TORQUE (mN·m)	7.8	9.8	19.6	19.6	29.4	39.2	39.2	58.8	68.6	88.2	127.4	137.2	166.6	196	245	343	490	588	588	588
	TORQUE (kgf·cm)	0.08	0.1	0.2	0.2	0.3	0.4	0.4	0.6	0.7	0.9	1.3	1.4	1.7	2	2.5	3.5	5	6	6	6
TG-301A-AMD (24V)	SPEED (r/min)	1157	609	390	332	237	195	161	117	97.8	77.9	57.8	48.4	38.7	29.5	23.6	19.3	11.7	—	—	—
	TORQUE (mN·m)	7.8	9.8	19.6	19.6	29.4	39.2	49	58.8	68.6	88.2	127.4	147	186.2	196	245	343	539	—	—	—
	TORQUE (kgf·cm)	0.08	0.1	0.2	0.2	0.3	0.4	0.5	0.6	0.7	0.9	1.3	1.5	1.9	2	2.5	3.5	5.5	—	—	—

AGD

GEAR RATIO	L1 (mm)	L2 (mm)	STAGE	TORQUE		WEIGHT (g)
				(mN·m)	(kgf·cm)	
1/5 ~ 1/10	26	0.5	2	98	1	90
1/12.5 ~ 1/30	26	3	3	196	2	95
1/36 ~ 1/100	26	5.5	4	294	3	100
1/120 ~ 1/300	31	3	5	588	6	105
1/360 ~ 1/1000	31	5.5	6	588	6	110
1/1500 ~ 1/3000	31	8	7	588	6	115

AMD

GEAR RATIO	L1 (mm)	L2 (mm)	STAGE	TORQUE		WEIGHT (g)
				(mN·m)	(kgf·cm)	
1/5 ~ 1/10	26	4	2	98	1	110
1/12.5 ~ 1/18	26	6.5	3	343	3.5	115
1/25 ~ 1/36	26	6.5	3	392	4	115
1/50 ~ 1/75	31	4	4	490	5	115
1/90 ~ 1/150	31	4	4	686	7	115
1/180 ~ 1/500	31	6.5	5	686	7	120

TG-05

(1.2 ~ 3.5W) $\phi 35.8$, COMPACT AND LONG LIFE, LOW NOISE, ENCODER CAN BE MOUNTED.

APPLICATION

LASER PRINTER / COPY MACHINE / FINISHER / STAMPER / TICKETING DEVICE / STACKER / MONEY COUNTING MACHINE / BILL BINDING MACHINE / COIN HOPPER / VENDING MACHINE / BUS FARE BOX / ATM / GAMING MACHINE / SECURITY CAMERA / X-RAY MACHINE / SEWING MACHINE / VALVE / PRINTING PRESS etc.

SS

TG-05J
TG-05K
TG-05L
TG-05R

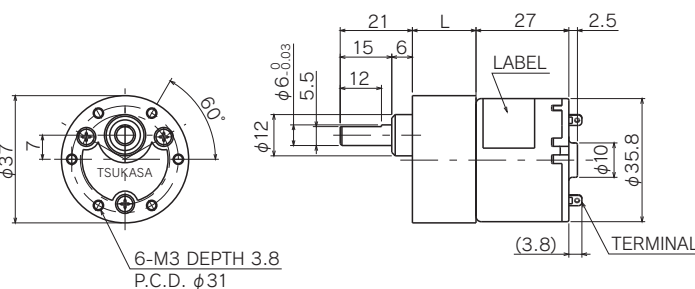

Allowable torque-speed characteristics SS

MODEL	GEAR RATIO	SS								
		115	149	191	248	286	371	477	619	
TG-05J-SS (24V)	SPEED (r/min)	35.7	28	22.6	18	15.8	12.4	9.8	7.6	
	TORQUE (mN·m)	245	294	294	294	294	294	294	294	
	TORQUE (kgf·cm)	2.5	3	3	3	3	3	3	3	
TG-05K-SS (24V)	SPEED (r/min)	51.9	40.6	32.6	25.9	22.6	17.7	14	10.9	
	TORQUE (mN·m)	245	294	294	294	294	294	294	294	
	TORQUE (kgf·cm)	2.5	3	3	3	3	3	3	3	
TG-05L-SS (24V)	SPEED (r/min)	71.7	57.5	45.9	36.2	31.6	24.7	19.4	15.1	
	TORQUE (mN·m)	294	294	294	294	294	294	294	294	
	TORQUE (kgf·cm)	3	3	3	3	3	3	3	3	
TG-05L-SS (12V)	SPEED (r/min)	34.7	27.5	20.8	16.8	14.8	11.8	9.4	7.3	
	TORQUE (mN·m)	176.4	196	294	294	294	294	294	294	
	TORQUE (kgf·cm)	1.8	2	3	3	3	3	3	3	
TG-05R-SS (12V)	SPEED (r/min)	50.1	37.9	30.5	24.1	21.1	16.5	13.0	10.1	
	TORQUE (mN·m)	196	294	294	294	294	294	294	294	
	TORQUE (kgf·cm)	3	3	3	3	3	3	3	3	

SS

GEAR RATIO	L (mm)	STAGE	TORQUE		WEIGHT (g)
			(mN·m)	(kgf·cm)	
1/115 ~ 1/248	20.5	6	294	3	129
1/286 ~ 1/619	22.8	7	294	3	131

SG/SM

TG-05D
TG-05J
TG-05K
TG-05L
TG-05R

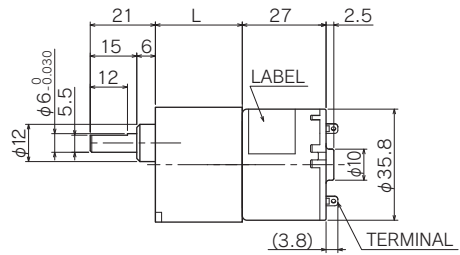
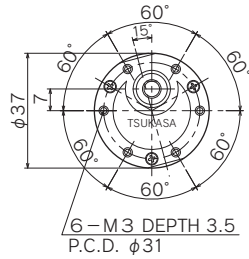

Allowable torque-speed characteristics

SG SM

MODEL	GEAR RATIO	1																			
		5	10	15	18	25	30	36	50	60	75	100	120	150	200	250	300	500	750	1000	1500
TG-05D-SG (6V)	SPEED (r/min)	1135	533	356	294	212	178	147	105	88.3	70.4	53	44.8	35.1	26.5	21.3	18.1	11.5	7.9	6.1	4.1
	TORQUE (mN·m)	9.8	29.4	39.2	49	68.6	78.4	88.2	127.4	147	186.2	245	245	343	441	539	588	588	588	588	588
	TORQUE (kgf·cm)	0.1	0.3	0.4	0.5	0.7	0.8	0.9	1.3	1.5	1.9	2.5	2.5	3.5	4.5	5.5	6	6	6	6	6
TG-05J-SG (24V)	SPEED (r/min)	883	417	279	231	162	136	113	81.3	67.6	54.7	41.5	33.9	27.5	20.4	16.4	14.1	8.9	6.1	4.7	3.2
	TORQUE (mN·m)	9.8	29.4	39.2	49	78.4	88.2	98	137.2	166.6	196	245	294	343	490	588	588	588	588	588	588
	TORQUE (kgf·cm)	0.1	0.3	0.4	0.5	0.8	0.9	1	1.4	1.7	2	2.5	3	3.5	5	6	6	6	6	6	6
TG-05K-SG (24V)	SPEED (r/min)	1271	605	404	335	235	198	164	118	98.3	79.5	60.2	49.3	39.9	29.6	23.9	20.4	12.8	8.8	6.7	4.5
	TORQUE (mN·m)	9.8	29.4	39.2	49	78.4	88.2	98	137.2	166.6	196	245	294	343	490	588	588	588	588	588	588
	TORQUE (kgf·cm)	0.1	0.3	0.4	0.5	0.8	0.9	1	1.4	1.7	2	2.5	3	3.5	5	6	6	6	6	6	6
TG-05L-SG (24V)	SPEED (r/min)	1643	821	554	462	329	277	230	165	137	113	83.2	68.4	55.6	41.5	33.8	28.8	17.9	12.2	9.3	6.2
	TORQUE (mN·m)	19.6	39.2	49	58.8	88.2	98	107.8	156.8	186.2	196	294	343	392	539	588	588	588	588	588	588
	TORQUE (kgf·cm)	0.2	0.4	0.5	0.6	0.9	1	1.1	1.6	1.9	2	3	3.5	4	5.5	6	6	6	6	6	6
TG-05L-SG (12V)	SPEED (r/min)	822	411	269	231	161	134	110	80.6	66.9	53.4	39.9	33.4	26.7	19.9	16.2	13.4	8.3	5.8	4.5	3
	TORQUE (mN·m)	9.8	19.6	29.4	29.4	49	58.8	68.6	88.2	107.8	137.2	186.2	196	245	343	392	490	588	588	588	588
	TORQUE (kgf·cm)	0.1	0.2	0.3	0.3	0.5	0.6	0.7	0.9	1.1	1.4	1.9	2	2.5	3.5	4	5	6	6	6	6
TG-05R-SG (12V)	SPEED (r/min)	1185	565	377	313	225	189	156	112	93.8	74.9	56.3	47.4	37.3	28.1	22.6	19.1	11.9	8.2	6.2	4.2
	TORQUE (mN·m)	9.8	29.4	39.2	49	68.6	78.4	88.2	127.4	147	186.2	245	245	343	441	539	588	588	588	588	588
	TORQUE (kgf·cm)	0.1	0.3	0.4	0.5	0.7	0.8	0.9	1.3	1.5	1.9	2.5	2.5	3.5	4.5	5.5	6	6	6	6	6
TG-05D-SM (6V)	SPEED (r/min)	1135	533	356	294	212	178	147	105	88.3	70.4	53	44.8	35.1	26.5	21.3	18.1	11.5	7.9	6.1	—
	TORQUE (mN·m)	9.8	29.4	39.2	49	68.6	78.4	88.2	127.4	147	186.2	245	245	343	441	539	588	588	588	588	—
	TORQUE (kgf·cm)	0.1	0.3	0.4	0.5	0.7	0.8	0.9	1.3	1.5	1.9	2.5	2.5	3.5	4.5	5.5	6	6	6	6	—
TG-05J-SM (24V)	SPEED (r/min)	883	417	279	231	162	136	113	81.3	67.6	54.7	41.5	33.9	27.5	20.4	16.4	14.1	8.9	6.1	4.7	—
	TORQUE (mN·m)	9.8	29.4	39.2	49	78.4	88.2	98	137.2	166.6	196	245	294	343	490	588	588	588	588	588	—
	TORQUE (kgf·cm)	0.1	0.3	0.4	0.5	0.8	0.9	1	1.4	1.7	2	2.5	3	3.5	5	6	6	6	6	6	—
TG-05K-SM (24V)	SPEED (r/min)	1271	605	404	335	235	198	164	118	98.3	79.5	60.2	49.3	39.9	29.6	23.9	20.4	12.8	8.8	6.7	—
	TORQUE (mN·m)	9.8	29.4	39.2	49	78.4	88.2	98	137.2	166.6	196	245	294	343	490	588	588	588	588	588	—
	TORQUE (kgf·cm)	0.1	0.3	0.4	0.5	0.8	0.9	1	1.4	1.7	2	2.5	3	3.5	5	6	6	6	6	6	—
TG-05L-SM (24V)	SPEED (r/min)	1643	821	554	462	329	277	230	165	137	113	83.2	68.4	55.6	41.5	33.8	28.8	17.9	12.2	9.3	—
	TORQUE (mN·m)	19.6	39.2	49	58.8	88.2	98	107.8	156.8	186.2	196	294	343	392	539	588	588	588	588	588	—
	TORQUE (kgf·cm)	0.2	0.4	0.5	0.6	0.9	1	1.1	1.6	1.9	2	3	3.5	4	5.5	6	6	6	6	6	—
TG-05L-SM (12V)	SPEED (r/min)	822	411	269	231	161	134	110	80.6	66.9	53.4	39.9	33.4	26.7	19.9	16.2	13.4	8.3	5.8	4.5	—
	TORQUE (mN·m)	9.8	19.6	29.4	29.4	49	58.8	68.6	88.2	107.8	137.2	186.2	196	245	343	392	490	588	588	588	—
	TORQUE (kgf·cm)	0.1	0.2	0.3	0.3	0.5	0.6	0.7	0.9	1.1	1.4	1.9	2	2.5	3.5	4	5	6	6	6	—
TG-05R-SM (12V)	SPEED (r/min)	1185	565	377	313	225	189	156	112	93.8	74.9	56.3	47.4	37.3	28.1	22.6	19.1	11.9	8.2	6.2	—
	TORQUE (mN·m)	9.8	29.4	39.2	49	68.6	78.4	88.2	127.4	147	186.2	245	245	343	441	539	588	588	588	588	—
	TORQUE (kgf·cm)	0.1	0.3	0.4	0.5	0.7	0.8	0.9	1.3	1.5	1.9	2.5	2.5	3.5	4.5	5.5	6	6	6	6	—

SG

GEAR RATIO	L (mm)	STAGE	TORQUE		WEIGHT (g)
			(mN·m)	(kgf·cm)	
1/5 ~ 1/10	20.5	2	98	1	100
1/12.5 ~ 1/30	23	3	196	2	105
1/36 ~ 1/100	25.5	4	294	3	110
1/120 ~ 1/300	28	5	588	6	115
1/360 ~ 1/1000	30.5	6	588	6	120
1/1500 ~ 1/3000	33	7	588	6	125

SM

GEAR RATIO	L (mm)	STAGE	TORQUE		WEIGHT (g)
			(mN·m)	(kgf·cm)	
1/5 ~ 1/10	23	2	98	1	100
1/12.5 ~ 1/30	25.5	3	196	2	105
1/36 ~ 1/100	28	4	294	3	110
1/120 ~ 1/300	30.5	5	588	6	115
1/360 ~ 1/1000	33	6	588	6	120

AGD/AMD

TG-05D
TG-05J
TG-05K
TG-05L
TG-05R

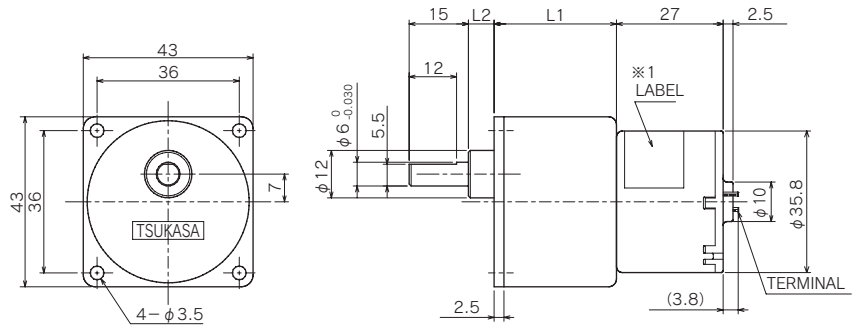

Allowable torque-speed characteristics AGD AMD

MODEL	GEAR RATIO	1																			
		5	10	15	18	25	30	36	50	60	75	100	120	150	200	250	300	500	750	1000	1500
TG-05D-AGD (6V)	SPEED (r/min)	1135	533	356	294	212	178	147	105	88.3	70.4	53	44.8	35.1	26.5	21.3	18.1	11.5	7.9	6.1	4.1
	TORQUE (mN·m)	9.8	29.4	39.2	49	68.6	78.4	88.2	127.4	147	186.2	245	245	343	441	539	588	588	588	588	588
	TORQUE (kgf·cm)	0.1	0.3	0.4	0.5	0.7	0.8	0.9	1.3	1.5	1.9	2.5	2.5	3.5	4.5	5.5	6	6	6	6	6
TG-05J-AGD (24V)	SPEED (r/min)	883	417	279	231	162	136	113	81.3	67.6	54.7	41.5	33.9	27.5	20.4	16.4	14.1	8.9	6.1	4.7	3.2
	TORQUE (mN·m)	9.8	29.4	39.2	49	78.4	88.2	98	137.2	166.6	196	245	294	343	490	588	588	588	588	588	588
	TORQUE (kgf·cm)	0.1	0.3	0.4	0.5	0.8	0.9	1	1.4	1.7	2	2.5	3	3.5	5	6	6	6	6	6	6
TG-05K-AGD (24V)	SPEED (r/min)	1271	605	404	335	235	198	164	118	98.3	79.5	60.2	49.3	39.9	29.6	23.9	20.4	12.8	8.8	6.7	4.5
	TORQUE (mN·m)	9.8	29.4	39.2	49	78.4	88.2	98	137.2	166.6	196	245	294	343	490	588	588	588	588	588	588
	TORQUE (kgf·cm)	0.1	0.3	0.4	0.5	0.8	0.9	1	1.4	1.7	2	2.5	3	3.5	5	6	6	6	6	6	6
TG-05L-AGD (24V)	SPEED (r/min)	1643	821	554	462	329	277	230	165	137	113	83.2	68.4	55.6	41.5	33.8	28.8	17.9	12.2	9.3	6.2
	TORQUE (mN·m)	19.6	39.2	49	58.8	88.2	98	107.8	156.8	186.2	196	294	343	392	539	588	588	588	588	588	588
	TORQUE (kgf·cm)	0.2	0.4	0.5	0.6	0.9	1	1.1	1.6	1.9	2	3	3.5	4	5.5	6	6	6	6	6	6
TG-05L-AGD (12V)	SPEED (r/min)	822	411	269	231	161	134	110	80.6	66.9	53.4	39.9	33.4	26.7	19.9	16.2	13.4	8.3	5.8	4.5	3
	TORQUE (mN·m)	9.8	19.6	29.4	29.4	49	58.8	68.6	88.2	107.8	137.2	186.2	196	245	343	392	490	588	588	588	588
	TORQUE (kgf·cm)	0.1	0.2	0.3	0.3	0.5	0.6	0.7	0.9	1.1	1.4	1.9	2	2.5	3.5	4	5	6	6	6	6
TG-05R-AGD (12V)	SPEED (r/min)	1185	565	377	313	225	189	156	112	93.8	74.9	56.3	47.4	37.3	28.1	22.6	19.1	11.9	8.2	6.2	4.2
	TORQUE (mN·m)	9.8	29.4	39.2	49	68.6	78.4	88.2	127.4	147	186.2	245	245	343	441	539	588	588	588	588	588
	TORQUE (kgf·cm)	0.1	0.3	0.4	0.5	0.7	0.8	0.9	1.3	1.5	1.9	2.5	2.5	3.5	4.5	5.5	6	6	6	6	6
TG-05D-AMD (6V)	SPEED (r/min)	1135	533	356	294	212	178	147	105	88.3	70.4	53	44.1	35.8	26.5	21.3	17.5	11.4	—	—	—
	TORQUE (mN·m)	9.8	29.4	39.2	49	68.6	78.4	98	127.4	147	186.2	245	294	343	441	539	686	686	—	—	—
	TORQUE (kgf·cm)	0.1	0.3	0.4	0.5	0.7	0.8	1	1.3	1.5	1.9	2.5	3	3.5	4.5	5.5	7	7	—	—	—
TG-05J-AMD (24V)	SPEED (r/min)	883	417	279	231	162	136	113	81.3	67.6	54.7	41.5	33.6	27.4	20.4	16.2	13.8	8.9	—	—	—
	TORQUE (mN·m)	9.8	29.4	39.2	49	78.4	88.2	107.8	137.2	166.6	196	245	343	392	490	637	686	686	—	—	—
	TORQUE (kgf·cm)	0.1	0.3	0.4	0.5	0.8	0.9	1.1	1.4	1.7	2	2.5	3.5	4	5	6.5	7	7	—	—	—
TG-05K-AMD (24V)	SPEED (r/min)	1271	605	404	335	235	198	165	118	98.3	79.5	60.2	48.9	39.7	29.6	23.5	20	12.8	—	—	—
	TORQUE (mN·m)	9.8	29.4	39.2	49	78.4	88.2	107.8	137.2	166.6	196	245	343	392	490	637	686	686	—	—	—
	TORQUE (kgf·cm)	0.1	0.3	0.4	0.5	0.8	0.9	1.1	1.4	1.7	2	2.5	3.5	4	5	6.5	7	7	—	—	—
TG-05L-AMD (24V)	SPEED (r/min)	1643	821	554	462	329	277	228	165	137	113	83.2	69.6	55.4	41.5	33.1	28.3	17.9	—	—	—
	TORQUE (mN·m)	19.6	39.2	49	58.8	88.2	98	127.4	156.8	186.2	196	294	343	441	539	686	686	686	—	—	—
	TORQUE (kgf·cm)	0.2	0.4	0.5	0.6	0.9	1	1.3	1.6	1.9	2	3	3.5	4.5	5.5	7	7	7	—	—	—
TG-05L-AMD (12V)	SPEED (r/min)	822	411	269	231	161	134	113	80.6	66.9	53.4	39.9	34.1	27.3	19.9	16.2	13.4	8.3	—	—	—
	TORQUE (mN·m)	9.8	19.6	29.4	29.4	49	58.8	68.6	88.2	107.8	137.2	186.2	196	245	343	392	490	686	—	—	—
	TORQUE (kgf·cm)	0.1	0.2	0.3	0.3	0.5	0.6	0.7	0.9	1.1	1.4	1.9	2	2.5	3.5	4	5	7	—	—	—
TG-05R-AMD (12V)	SPEED (r/min)	1185	565	377	313	225	189	156	112	93.8	74.9	56.3	46.9	37.9	28.1	22.6	18.7	11.9	—	—	—
	TORQUE (mN·m)	9.8	29.4	39.2	49	68.6	78.4	98	127.4	147	186.2	245	294	343	441	539	686	686	—	—	—
	TORQUE (kgf·cm)	0.1	0.3	0.4	0.5	0.7	0.8	1	1.3	1.5	1.9	2.5	3	3.5	4.5	5.5	7	7	—	—	—

AGD

GEAR RATIO	L1 (mm)	L2 (mm)	STAGE	TORQUE		WEIGHT (g)
				(mN·m)	(kgf·cm)	
1/5 ~ 1/10	26	0.5	2	98	1	90
1/12.5 ~ 1/30	26	3	3	196	2	95
1/36 ~ 1/100	26	5.5	4	294	3	100
1/120 ~ 1/300	31	3	5	588	6	105
1/360 ~ 1/1000	31	5.5	6	588	6	110
1/1500 ~ 1/3000	31	8	7	588	6	115

AMD

GEAR RATIO	L1 (mm)	L2 (mm)	STAGE	TORQUE		WEIGHT (g)
				(mN·m)	(kgf·cm)	
1/5 ~ 1/10	26	4	2	98	1	110
1/12.5 ~ 1/18	26	6.5	3	343	3.5	115
1/25 ~ 1/36	26	6.5	3	392	4	115
1/50 ~ 1/75	31	4	4	490	5	115
1/90 ~ 1/150	31	4	4	686	7	115
1/180 ~ 1/500	31	6.5	5	686	7	120

SU

TG-05D
TG-05J
TG-05K
TG-05L
TG-05R

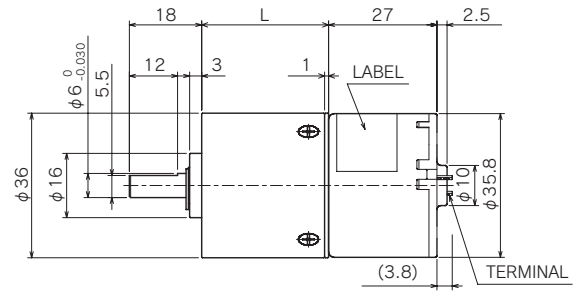
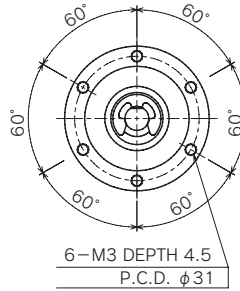

Allowable torque-speed characteristics SU

MODEL	GEAR RATIO	1	1	1	1	1	1	1	1	1	1	1	1	1	
		3.6	4.8	13.2	17.6	23.5	47.9	63.9	85.3	114	174	232	310	413	552
TG-05D-SU (6V)	SPEED (r/min)	1413	1100	379	279	209	102	76.4	58.1	43.1	28	21.1	15.7	12.2	9.5
	TORQUE (mN·m)	9.8	9.8	39.2	58.8	78.4	137.2	196	245	343	441	637	882	980	980
TG-05J-SU (24V)	SPEED (r/min)	1110	774	286	213	161	78.3	60.2	44.1	33	21.6	16.1	12.1	9.6	7.5
	TORQUE (mN·m)	9.8	19.6	49	68.6	88.2	156.8	196	294	392	490	735	980	980	980
TG-05K-SU (24V)	SPEED (r/min)	1581	1113	410	306	231	113	86.2	63.4	47.5	31.1	23.2	17.4	13.7	10.6
	TORQUE (mN·m)	9.8	19.6	49	68.6	88.2	156.8	196	294	392	490	735	980	980	980
TG-05L-SU (24V)	SPEED (r/min)	2255	1607	592	442	327	159	120	91.4	67.2	44.1	33.1	25.1	19.6	15.1
	TORQUE (mN·m)	9.8	19.6	49	68.6	98	176.4	245	294	441	539	784	980	980	980
TG-05R-SU (12V)	SPEED (r/min)	957	762	272	204	149	73.8	54.5	41	31.2	20.5	15	11.3	8.4	6.5
	TORQUE (mN·m)	9.8	9.8	29.4	39.2	58.8	98	147	196	245	294	490	637	882	980
TG-05R-SU (12V)	SPEED (r/min)	1521	1173	411	304	228	111	83.3	63.1	47	30.6	23	17.1	13.2	10.2
	TORQUE (mN·m)	9.8	9.8	39.2	58.8	78.4	137.2	196	245	343	441	637	882	980	980
TG-05R-SU (12V)	TORQUE (kgf·cm)	0.1	0.1	0.4	0.6	0.8	1.4	2	2.5	3.5	4.5	6.5	9	10	10

SU

GEAR RATIO	L (mm)	STAGE	TORQUE		WEIGHT (g)
			(mN·m)	(kgf·cm)	
1/3.6 ~ 1/4.8	23.5	1	294	3	120
1/13.2 ~ 1/23.5	31.6	2	558	6	160
1/47.9 ~ 1/114	38.6	3	980	10	195
1/174 ~ 1/552	45.7	4	980	10	235

TG-06

(4.3 ~ 4.4W) 5-SLOT,
COMPACT SIZE, HIGH POWER.

APPLICATION

VENDING MACHINE / COIN HOPPER / CUTTER / GAMING MACHINE / MEDICAL EQUIPMENT /
BANKING MACHINE etc.

AGD/AMD

TG-06D
TG-06E

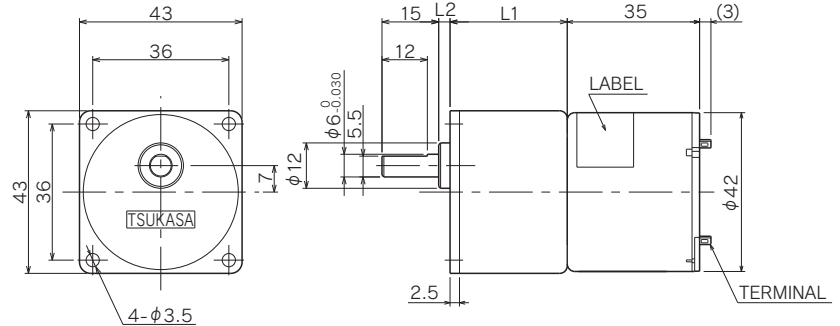

Allowable torque-speed characteristics AGD AMD

MODEL	GEAR RATIO	1	1	1	1	1	1	1	1	1	1	1	1	1	1	1	1	1	1	1	1	1
		5	10	15	18	25	30	36	50	60	75	100	120	150	200	250	300	500	750	1000	1500	
TG-06D-AGD (12V)	SPEED (r/min)	835	418	283	232	167	141	120	84.9	73.1	60.4	46.7	35.9	29.8	23.1	18.9	15.9	9.8	6.6	5	3.3	
	TORQUE (mN·m)	39.2	78.4	98	127.4	176.4	196	196	294	294	294	294	588	588	588	588	588	588	588	588	588	
	TORQUE (kgf·cm)	0.4	0.8	1	1.3	1.8	2	2	3	3	3	3	6	6	6	6	6	6	6	6	6	
TG-06E-AGD (24V)	SPEED (r/min)	825	413	279	229	165	139	118	83.7	71.7	59	45.4	35.3	29.1	22.5	18.3	15.4	9.4	6.4	4.8	3.2	
	TORQUE (mN·m)	39.2	78.4	98	127.4	176.4	196	196	294	294	294	294	588	588	588	588	588	588	588	588	588	
	TORQUE (kgf·cm)	0.4	0.8	1	1.3	1.8	2	2	3	3	3	3	6	6	6	6	6	6	6	6	6	
TG-06D-AMD (12V)	SPEED (r/min)	835	418	283	232	167	141	117	84.9	71.1	56.6	41.7	35.6	29.6	22.7	18.6	15.8	9.8	—	—	—	
	TORQUE (mN·m)	39.2	78.4	98	127.4	176.4	196	245	294	343	441	637	686	686	686	686	686	686	—	—	—	
	TORQUE (kgf·cm)	0.4	0.8	1	1.3	1.8	2	2.5	3	3.5	4.5	6.5	7	7	7	7	7	7	—	—	—	
TG-06E-AMD (24V)	SPEED (r/min)	825	413	279	229	165	139	115	83.7	70	55.8	41.2	35	28.9	22.2	18.1	15.3	9.4	—	—	—	
	TORQUE (mN·m)	39.2	78.4	98	127.4	176.4	196	245	294	343	441	637	686	686	686	686	686	686	—	—	—	
	TORQUE (kgf·cm)	0.4	0.8	1	1.3	1.8	2	2.5	3	3.5	4.5	6.5	7	7	7	7	7	7	—	—	—	

AGD

GEAR RATIO	L1 (mm)	L2 (mm)	STAGE	TORQUE		WEIGHT (g)
				(mN·m)	(kgf·cm)	
1/5 ~ 1/10	26	0.5	2	98	1	90
1/12.5 ~ 1/30	26	3	3	196	2	95
1/36 ~ 1/100	26	5.5	4	294	3	100
1/120 ~ 1/300	31	3	5	588	6	105
1/360 ~ 1/1000	31	5.5	6	588	6	110
1/1500 ~ 1/3000	31	8	7	588	6	115

AMD

GEAR RATIO	L1 (mm)	L2 (mm)	STAGE	TORQUE		WEIGHT (g)
				(mN·m)	(kgf·cm)	
1/5 ~ 1/10	26	4	2	98	1	110
1/12.5 ~ 1/18	26	6.5	3	343	3.5	115
1/25 ~ 1/36	26	6.5	3	392	4	115
1/50 ~ 1/75	31	4	4	490	5	115
1/90 ~ 1/150	31	4	4	686	7	115
1/180 ~ 1/500	31	6.5	5	686	7	120

SU

TG-06D
TG-06E

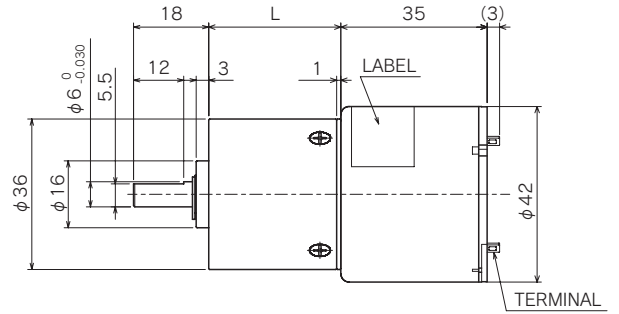
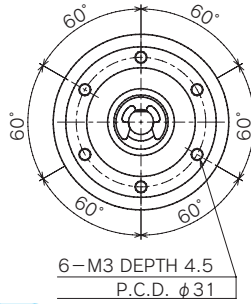

Allowable torque-speed characteristics SU

MODEL	GEAR RATIO	1	1	1	1	1	1	1	1	1	1	1	1	1	
		3.6	4.8	13.2	17.6	23.5	47.9	63.9	85.3	174	114	232	310	413	552
TG-06D-SU (12V)	SPEED (r/min)	1139	855	309	232	174	84.9	63.4	47.9	35.6	23.9	19	14.7	11.3	8.6
	TORQUE (mN·m)	29.4	39.2	107.8	147	196	343	490	637	882	980	980	980	980	980
	TORQUE (kgf·cm)	0.3	0.4	1.1	1.5	2	3.5	5	6.5	9	10	10	10	10	10
TG-06E-SU (24V)	SPEED (r/min)	1123	843	306	229	172	84	62.7	47.3	35.2	23.5	18.6	14.3	10.9	8.3
	TORQUE (mN·m)	29.4	39.2	107.8	147	196	343	490	637	882	980	980	980	980	980
	TORQUE (kgf·cm)	0.3	0.4	1.1	1.5	2	3.5	5	6.5	9	10	10	10	10	10

SU

GEAR RATIO	L (mm)	STAGE	TORQUE		WEIGHT (g)
			(mN·m)	(kgf·cm)	
1/3.6 ~ 1/4.8	23.5	1	294	3	120
1/13.2 ~ 1/23.5	31.6	2	558	6	160
1/47.9 ~ 1/114	38.6	3	980	10	195
1/174 ~ 1/552	45.7	4	980	10	235

BG

TG-06D
TG-06E

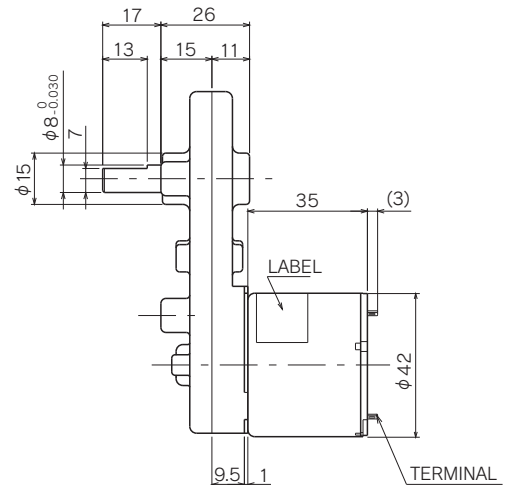
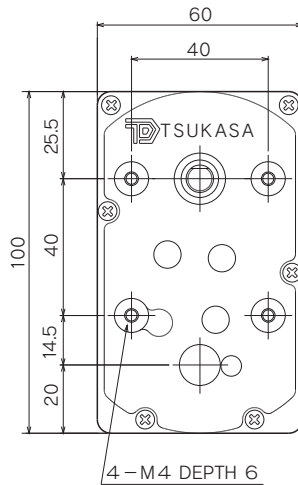

Allowable torque-speed characteristics BG

MODEL	GEAR RATIO	1	1	1	1	1	1	1	1	1	
		12.5	25	36	60	100	150	200	300	500	700
TG-06D-BG (12V)	SPEED (r/min)	334	167	117	70.7	42	28.3	21	15.4	9.1	6.7
	TORQUE (mN·m)	88.2	176.4	245	392	686	980	1372	980	1960	1960
	TORQUE (kgf·cm)	0.9	1.8	2.5	4	7	10	14	10	20	20
TG-06E-BG (24V)	SPEED (r/min)	330	165	115	69.7	41.5	27.9	20.7	15	8.8	6.5
	TORQUE (mN·m)	88.2	176.4	245	392	686	980	1372	980	1960	1960
	TORQUE (kgf·cm)	0.9	1.8	2.5	4	7	10	14	10	20	20

BG

GEAR RATIO	STAGE	TORQUE		WEIGHT (g)
		(mN·m)	(kgf·cm)	
1/12.5 ~ 1/18	3	686	7	315
1/25 ~ 1/90	3	980	10	315
1/100 ~ 1/200	3	1470	15	315
1/250, 1/500, 1/700	4	1960	20	315
1/300	4	980	10	285

TG-85

(5.5 ~ 8.0W) 5-SLOT,
LOW COST, HIGHLY-RELIABLE MOTOR.

APPLICATION

COPY MACHINE / GAMING MACHINE / MEDICAL EQUIPMENT / VENDING MACHINE / ATM / LASER PRINTER /
STAMPER / PRINTING PRESS / SEWING MACHINE / BANKNOTE COUNTER / HOPPER /
SEMICONDUCTOR CLEANING DEVICE / CUTTER etc.

SG/SM

TG-85B
TG-85C
TG-85E

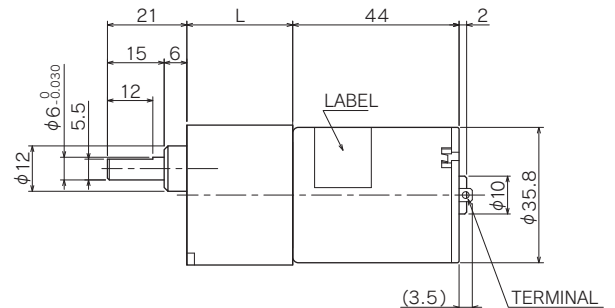
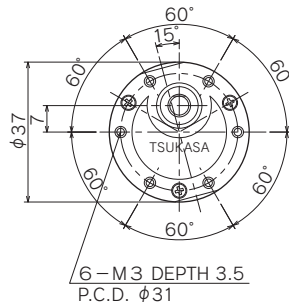

Allowable torque-speed characteristics

SG SM

MODEL	GEAR RATIO	1																			
		5	10	15	18	25	30	36	50	60	75	100	120	150	200	250	300	500	750	1000	1500
TG-85B-SG (12V)	SPEED (r/min)	913	448	295	247	179	154	125	92.4	78.9	64.6	49.6	38.9	32	24.6	20	16.8	10.3	6.9	5.2	3.5
	TORQUE (mN·m)	39.2	88.2	127.4	147	196	196	245	294	294	294	294	588	588	588	588	588	588	588	588	588
	TORQUE (kgf·cm)	0.4	0.9	1.3	1.5	2	2	2.5	3	3	3	3	6	6	6	6	6	6	6	6	6
TG-85C-SG (24V)	SPEED (r/min)	910	447	294	247	179	153	125	91.9	78.3	63.9	49	38.7	31.7	24.3	19.7	16.6	10.1	6.8	5.1	3.4
	TORQUE (mN·m)	39.2	88.2	127.4	147	196	196	245	294	294	294	294	588	588	588	588	588	588	588	588	588
	TORQUE (kgf·cm)	0.4	0.9	1.3	1.5	2	2	2.5	3	3	3	3	6	6	6	6	6	6	6	6	6
TG-85E-SG (24V)	SPEED (r/min)	1302	643	425	356	257	219	180	131	111	90.1	68.6	55	44.7	34.1	27.6	23.1	14	9.4	7.1	4.7
	TORQUE (mN·m)	39.2	88.2	127.4	147	196	196	245	294	294	294	294	588	588	588	588	588	588	588	588	588
	TORQUE (kgf·cm)	0.4	0.9	1.3	1.5	2	2	2.5	3	3	3	3	6	6	6	6	6	6	6	6	6
TG-85B-SM (12V)	SPEED (r/min)	913	448	295	247	179	154	125	92.4	78.9	64.6	49.6	38.9	32	24.6	20	16.8	10.3	6.9	5.2	—
	TORQUE (mN·m)	39.2	88.2	127.4	147	196	196	245	294	294	294	294	588	588	588	588	588	588	588	588	—
	TORQUE (kgf·cm)	0.4	0.9	1.3	1.5	2	2	2.5	3	3	3	3	6	6	6	6	6	6	6	6	—
TG-85C-SM (24V)	SPEED (r/min)	910	447	294	247	179	153	125	91.9	78.3	64	49	38.7	31.7	24.3	19.7	16.6	10.1	6.8	5.1	—
	TORQUE (mN·m)	39.2	88.2	127.4	147	196	196	245	294	294	294	294	588	588	588	588	588	588	588	588	—
	TORQUE (kgf·cm)	0.4	0.9	1.3	1.5	2	2	2.5	3	3	3	3	6	6	6	6	6	6	6	6	—
TG-85E-SM (24V)	SPEED (r/min)	1302	643	425	356	257	219	180	131	111	90.1	68.6	55	44.7	34.1	27.6	23.1	14	9.4	7.1	—
	TORQUE (mN·m)	39.2	88.2	127.4	147	196	196	245	294	294	294	294	588	588	588	588	588	588	588	588	—
	TORQUE (kgf·cm)	0.4	0.9	1.3	1.5	2	2	2.5	3	3	3	3	6	6	6	6	6	6	6	6	—

SG

GEAR RATIO	L (mm)	STAGE	TORQUE		WEIGHT (g)
			(mN·m)	(kgf·cm)	
1/5 ~ 1/10	20.5	2	98	1	100
1/12.5 ~ 1/30	23	3	196	2	105
1/36 ~ 1/100	25.5	4	294	3	110
1/120 ~ 1/300	28	5	588	6	115
1/360 ~ 1/1000	30.5	6	588	6	120
1/1500 ~ 1/3000	33	7	588	6	125

SM

GEAR RATIO	L (mm)	STAGE	TORQUE		WEIGHT (g)
			(mN·m)	(kgf·cm)	
1/5 ~ 1/10	23	2	98	1	100
1/12.5 ~ 1/30	25.5	3	196	2	105
1/36 ~ 1/100	28	4	294	3	110
1/120 ~ 1/300	30.5	5	588	6	115
1/360 ~ 1/1000	33	6	588	6	120

AGD/AMD

TG-85B
TG-85C
TG-85E

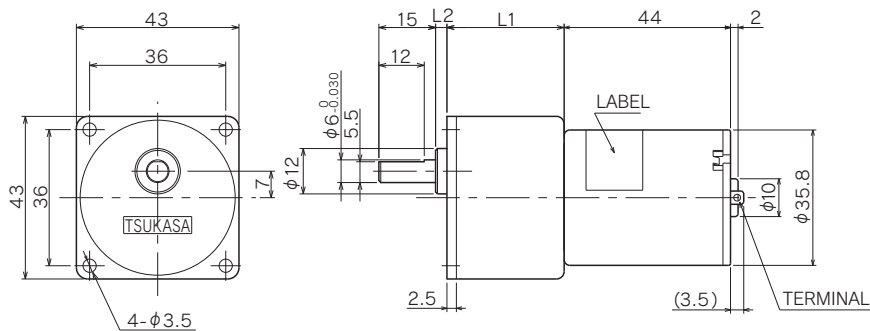

Allowable torque-speed characteristics AGD AMD

MODEL	GEAR RATIO	1	1	1	1	1	1	1	1	1	1	1	1	1	1	1	1	1	1	1	1	1	1	1	
		5	10	15	18	25	30	36	50	60	75	100	120	150	200	250	300	500	750	1000	1500				
TG-85B-AGD (12V)	SPEED (r/min)	913	448	295	247	179	154	125	92.4	78.9	64.6	49.6	38.9	32	24.6	20	16.8	10.3	6.9	5.2	3.5				
	TORQUE (mN·m)	39.2	88.2	127.4	147	196	196	245	294	294	294	294	588	588	588	588	588	588	588	588	588	588	588	588	
	TORQUE (kgf·cm)	0.4	0.9	1.3	1.5	2	2	2.5	3	3	3	3	6	6	6	6	6	6	6	6	6	6	6	6	
TG-85C-AGD (24V)	SPEED (r/min)	910	447	294	247	179	153	125	91.9	78.3	63.9	49	38.7	31.7	24.3	19.7	16.6	10.1	6.8	5.1	3.4				
	TORQUE (mN·m)	39.2	88.2	127.4	147	196	196	245	294	294	294	294	588	588	588	588	588	588	588	588	588	588	588	588	
	TORQUE (kgf·cm)	0.4	0.9	1.3	1.5	2	2	2.5	3	3	3	3	6	6	6	6	6	6	6	6	6	6	6	6	
TG-85E-AGD (24V)	SPEED (r/min)	1302	643	425	356	257	219	180	131	111	90.1	68.6	55	44.7	34.1	27.6	23.1	14	9.4	7.1	4.7				
	TORQUE (mN·m)	9.2	88.2	127.4	147	196	196	245	294	294	294	294	588	588	588	588	588	588	588	588	588	588	588	588	
	TORQUE (kgf·cm)	0.4	0.9	1.3	1.5	2	2	2.5	3	3	3	3	6	6	6	6	6	6	6	6	6	6	6	6	
TG-85B-AMD (12V)	SPEED (r/min)	913	448	295	247	179	148	124	90.2	74.2	60.6	45.1	38.7	31.8	24.3	19.8	16.7	10.2	—	—	—				
	TORQUE (mN·m)	39.2	88.2	127.4	147	196	245	294	343	441	490	686	686	686	686	686	686	686	686	686	686	686	686	686	
	TORQUE (kgf·cm)	0.4	0.9	1.3	1.5	2	2.5	3	3.5	4.5	5	7	7	7	7	7	7	7	7	7	7	7	7	7	
TG-85C-AMD (24V)	SPEED (r/min)	910	447	294	247	179	148	124	89.9	74.1	60.4	45	38.4	31.5	24	19.5	16.5	10.1	—	—	—				
	TORQUE (mN·m)	39.2	88.2	127.4	147	196	245	294	343	441	490	686	686	686	686	686	686	686	686	686	686	686	686	686	
	TORQUE (kgf·cm)	0.4	0.9	1.3	1.5	2	2.5	3	3.5	4.5	5	7	7	7	7	7	7	7	7	7	7	7	7	7	
TG-85E-AMD (24V)	SPEED (r/min)	1302	643	425	356	257	214	178	129	107	86.5	64.6	54.8	44.6	33.8	27.4	23	14	—	—	—				
	TORQUE (mN·m)	39.2	88.2	127.4	147	196	245	294	343	441	490	686	686	686	686	686	686	686	686	686	686	686	686	686	
	TORQUE (kgf·cm)	0.4	0.9	1.3	1.5	2	2.5	3	3.5	4.5	5	7	7	7	7	7	7	7	7	7	7	7	7	7	

AGD

GEAR RATIO	L1 (mm)	L2 (mm)	STAGE	TORQUE		WEIGHT (g)
				(mN·m)	(kgf·cm)	
1/5 ~ 1/10	26	0.5	2	98	1	90
1/12.5 ~ 1/30	26	3	3	196	2	95
1/36 ~ 1/100	26	5.5	4	294	3	100
1/120 ~ 1/300	31	3	5	588	6	105
1/360 ~ 1/1000	31	5.5	6	588	6	110
1/1500 ~ 1/3000	31	8	7	588	6	115

AMD

GEAR RATIO	L1 (mm)	L2 (mm)	STAGE	TORQUE		WEIGHT (g)
				(mN·m)	(kgf·cm)	
1/5 ~ 1/10	26	4	2	98	1	110
1/12.5 ~ 1/18	26	6.5	3	343	3.5	115
1/25 ~ 1/36	26	6.5	3	392	4	115
1/50 ~ 1/75	31	4	4	490	5	115
1/90 ~ 1/150	31	4	4	686	7	115
1/180 ~ 1/500	31	6.5	5	686	7	120

SU

TG-85B
TG-85C
TG-85E

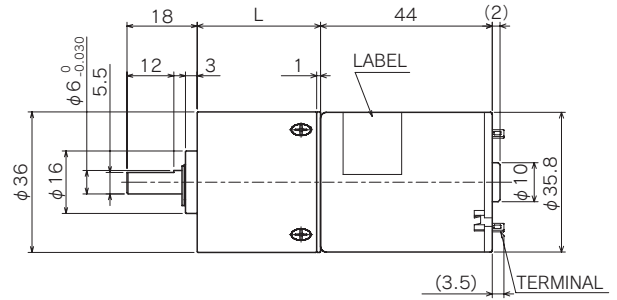
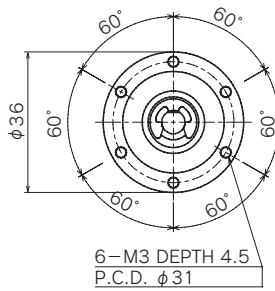

Allowable torque-speed characteristics SU

MODEL	GEAR RATIO	1													
		3.6	4.8	13.2	17.6	23.5	47.9	63.9	85.3	114	174	232	310	413	552
TG-85B-SU (12V)	SPEED (r/min)	1185	901	330	244	183	91.2	67.5	50.7	38.5	26.1	20.4	15.7	11.9	9.1
	TORQUE (mN·m)	39.2	49	127.4	186.2	245	392	588	784	980	980	980	980	980	980
	TORQUE (kgf·cm)	0.4	0.5	1.3	1.9	2.5	4	6	8	10	10	10	10	10	10
TG-85C-SU (24V)	SPEED (r/min)	1194	907	332	246	185	91.7	68	51.1	38.7	26.1	20.4	15.6	11.8	9
	TORQUE (mN·m)	39.2	49	127.4	186.2	245	392	588	784	980	980	980	980	980	980
	TORQUE (kgf·cm)	0.4	0.5	1.3	1.9	2.5	4	6	8	10	10	10	10	10	10
TG-85E-SU (24V)	SPEED (r/min)	1722	1302	477	355	266	132	97.9	73.5	55.5	37.1	28.6	21.8	16.5	12.4
	TORQUE (mN·m)	39.2	49	127.4	186.2	245	392	588	784	980	980	980	980	980	980
	TORQUE (kgf·cm)	0.4	0.5	1.3	1.9	2.5	4	6	8	10	10	10	10	10	10

SU

GEAR RATIO	L (mm)	STAGE	TORQUE		WEIGHT (g)
			(mN·m)	(kgf·cm)	
1/3.6 ~ 1/4.8	23.5	1	294	3	120
1/13.2 ~ 1/23.5	31.6	2	558	6	160
1/47.9 ~ 1/114	38.6	3	980	10	195
1/174 ~ 1/552	45.7	4	980	10	235

KU

TG-85B
TG-85C
TG-85E

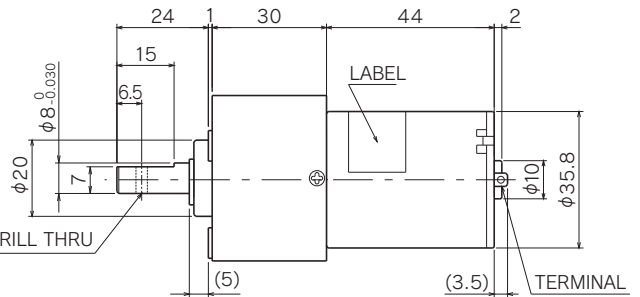
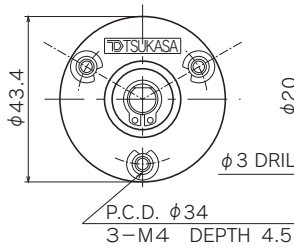

Allowable torque-speed characteristics KU

MODEL	GEAR RATIO	1											
		10	13	16	19	24	36	59	75	96	113	144	216
TG-85B-KU (12V)	SPEED (r/min)	448	355	279	235	187	125	75.4	58.8	46.3	39.2	31.5	22.2
	TORQUE (mN·m)	88.2	108	137	167	196	294	441	588	735	882	980	980
	TORQUE (kgf·cm)	0.9	1.1	1.4	1.7	2	3	4.5	6	7.5	9	10	10
TG-85C-KU (24V)	SPEED (r/min)	447	354	278	235	187	125	75.3	58.7	46.3	39.2	31.4	22
	TORQUE (mN·m)	88.2	108	137	167	196	294	441	588	735	882	980	980
	TORQUE (kgf·cm)	0.9	1.1	1.4	1.7	2	3	4.5	6	7.5	9	10	10
TG-85E-KU (24V)	SPEED (r/min)	646	510	401	339	269	179	108	84.7	66.7	56.5	45	31.1
	TORQUE (mN·m)	88.2	108	137	167	196	294	441	588	735	882	980	980
	TORQUE (kgf·cm)	0.9	1.1	1.4	1.7	2	3	4.5	6	7.5	9	10	10

KU

GEAR RATIO	STAGE	TORQUE		WEIGHT (g)
		(mN·m)	(kgf·cm)	
1/10 ~ 1/36	2	980	10	135
1/59 ~ 1/216	3	980	10	135

BE

TG-85B
TG-85C
TG-85E

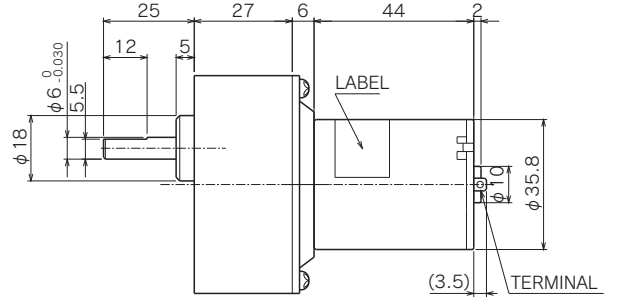
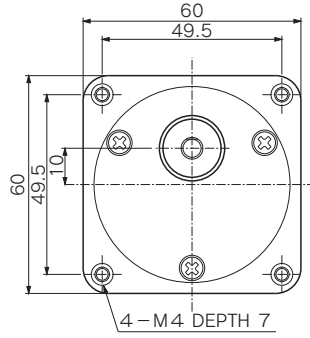

Allowable torque-speed characteristics

BE

MODEL	GEAR RATIO	1	1	1	1	1	1	1	1	1	1	1	1	1	1	1	
		5	10	12.5	15	18	25	30	50	75	100	150	200	300	500	750	1000
TG-85B-BE (12V)	SPEED (r/min)	926	448	354	295	247	185	148	89.7	59.6	44.5	30.3	23.7	16.1	10	6.8	5.1
	TORQUE (mN·m)	39.2	88.2	117.6	127.4	147	196	245	392	539	735	980	980	980	980	980	980
	TORQUE (kgf·cm)	0.4	0.9	1.2	1.3	1.5	2	2.5	4	5.5	7.5	10	10	10	10	10	10
TG-85C-BE (24V)	SPEED (r/min)	922	447	354	294	247	185	148	89.5	59.5	44.5	30.2	23.5	16	9.9	6.7	5
	TORQUE (mN·m)	39.2	88.2	117.6	127.4	147	196	245	392	539	735	980	980	980	980	980	980
	TORQUE (kgf·cm)	0.4	0.9	1.2	1.3	1.5	2	2.5	4	5.5	7.5	10	10	10	10	10	10
TG-85E-BE (24V)	SPEED (r/min)	1321	643	510	425	356	267	214	129	85.6	64.1	43.3	33.3	22.4	13.8	9.3	7
	TORQUE (mN·m)	39.2	88.2	117.6	127.4	147	196	245	392	539	735	980	980	980	980	980	980
	TORQUE (kgf·cm)	0.4	0.9	1.2	1.3	1.5	2	2.5	4	5.5	7.5	10	10	10	10	10	10

BE

GEAR RATIO	STAGE	TORQUE		WEIGHT (g)
		(mN·m)	(kgf·cm)	
1/3 ~ 1/12.5	2	980	10	255
1/15 ~ 1/60	3	980	10	270
1/75 ~ 1/250	4	980	10	285
1/300 ~ 1/1000	5	980	10	300

BG

TG-85B
TG-85C
TG-85E

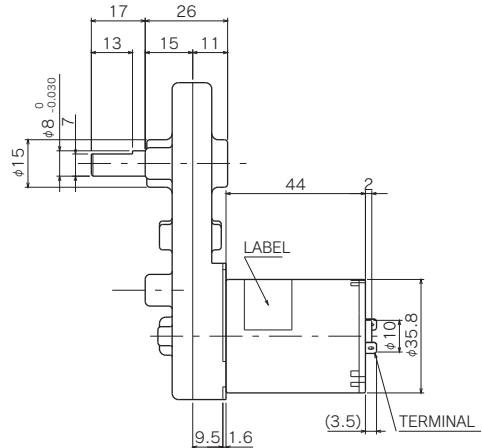
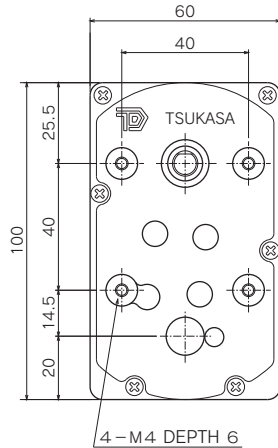

Allowable torque-speed characteristics

BG

MODEL	GEAR RATIO	1	1	1	1	1	1	1	1	1	
		12.5	25	36	60	100	150	200	300	500	700
TG-85B-BG (12V)	SPEED (r/min)	359	179	124	74.2	44.4	29.5	22.7	16.4	9.7	7.1
	TORQUE (mN·m)	98	196	294	490	833	1274	1470	980	1960	1960
	TORQUE (kgf·cm)	1	2	3	5	8.5	13	15	10	20	20
TG-85C-BG (24V)	SPEED (r/min)	358	179	124	74.1	44.3	29.4	22.6	16.2	9.6	7
	TORQUE (mN·m)	98	196	294	490	833	1274	1470	980	1960	1960
	TORQUE (kgf·cm)	1	2	3	5	8.5	13	15	10	20	20
TG-85E-BG (24V)	SPEED (r/min)	515	257	178	107	63.9	42.5	32.4	22.7	13.5	9.8
	TORQUE (mN·m)	98	196	294	490	833	1274	1470	980	1960	1960
	TORQUE (kgf·cm)	1	2	3	5	8.5	13	15	10	20	20

BG

GEAR RATIO	STAGE	TORQUE		WEIGHT (g)
		(mN·m)	(kgf·cm)	
1/12.5 ~ 1/18	3	686	7	315
1/25 ~ 1/90	3	980	10	315
1/100 ~ 1/200	3	1470	15	315
1/250, 1/500, 1/700	4	1960	20	315
1/300	4	980	10	285

TG-401

(11W) $\phi 46.5$, 5-SLOT AND LONG LIFE.

APPLICATION

PRINTER / PLOTTER / HOPPER / CUTTER / GAMING MACHINE / VENDING MACHINE / BANKING MACHINE etc.

BE

TG-401A

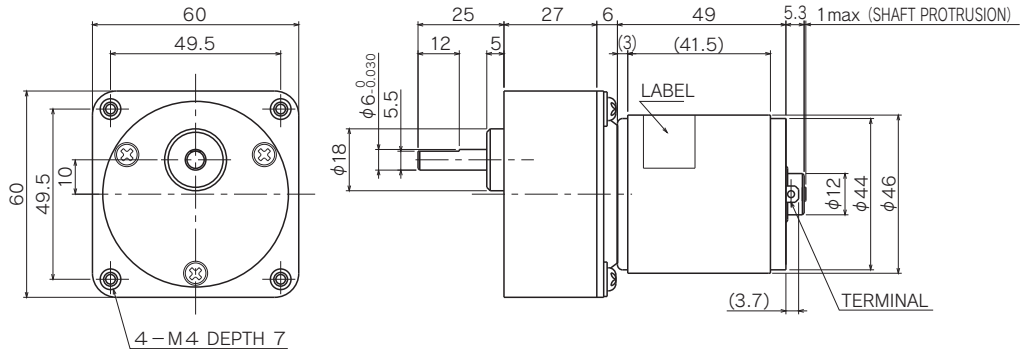

Allowable torque-speed characteristics

BE

MODEL	GEAR RATIO	1	1	1	1	1	1	1	1	1	1	1	1	1	1	1	
		5	10	12.5	15	18	25	30	50	75	100	150	200	300	500	750	1000
TG-401A-BE (24V)	SPEED (r/min)	803	396	317	268	224	164	132	79.3	54.8	42.8	29.7	22.7	15.3	9.3	6.3	4.7
	TORQUE (mN·m)	98	196	245	245	294	441	539	882	980	980	980	980	980	980	980	980
	TORQUE (kgf·cm)	1	2	2.5	2.5	3	4.5	5.5	9	10	10	10	10	10	10	10	10

BE

GEAR RATIO	STAGE	TORQUE		WEIGHT (g)
		(mN·m)	(kgf·cm)	
1/3 ~ 1/12.5	2	980	10	255
1/15 ~ 1/60	3	980	10	270
1/75 ~ 1/250	4	980	10	285
1/300 ~ 1/1000	5	980	10	300

BM

TG-401A

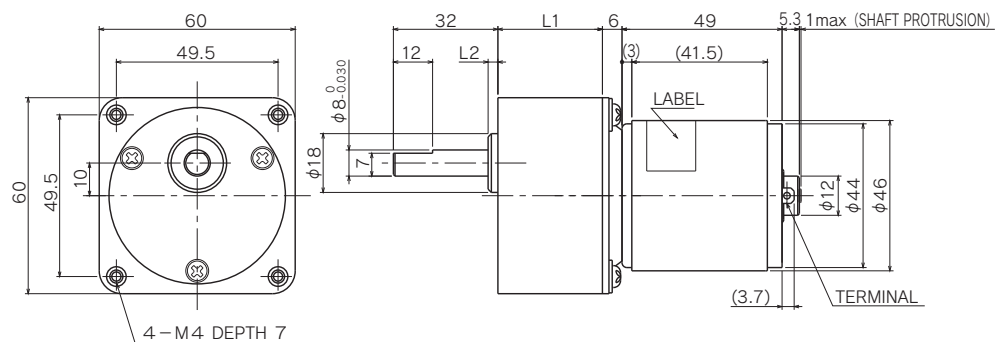

Allowable torque-speed characteristics

BM

MODEL	GEAR RATIO	1	1	1	1	1	1	1	1	1	1	1	1
		5	10	12.5	18	25	30	50	75	100	120	150	180
TG-401A-BM (24V)	SPEED (r/min)	793	396	317	224	159	132	79.3	53	39.2	32.8	26.3	24.1
	TORQUE (mN·m)	98	196	245	294	441	539	882	1176	1666	1960	2450	2450
	TORQUE (kgf·cm)	1	2	2.5	3	4.5	5.5	9	12	17	20	25	25

BM

GEAR RATIO	L1 (mm)	L2 (mm)	STAGE	TORQUE		WEIGHT (g)
				(mN·m)	(kgf·cm)	
1/3 ~ 1/15	32	3	2	1470	15	310
1/18 ~ 1/60	42	5	3	2450	25	400
1/75 ~ 1/180	42	5	4	2450	25	430

TG-21

(13 ~ 17W) $\phi 46.5$, 5-SLOT,
HIGHLY-RELIABLE AND HIGH-TORQUE.

APPLICATION

BUS DESTINATION INDICATOR / STIRRING MECHANISM / SECURITY CAMERA / MONEY COUNTING MACHINE / DENTAL MACHINE / BILL SORTER / CUTTER etc.

BE

TG-21Q
TG-21R

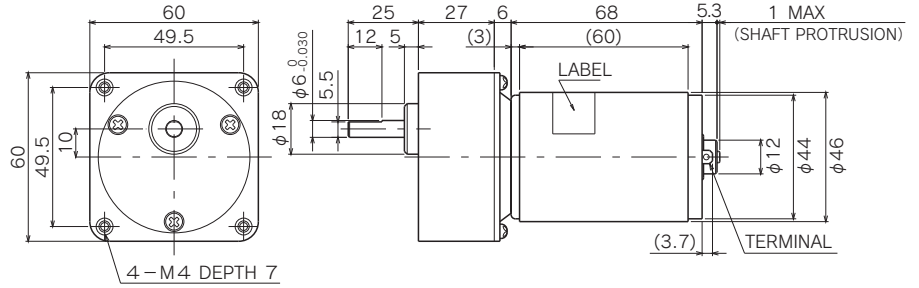
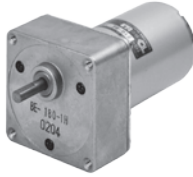

Allowable torque-speed characteristics

BE

MODEL	GEAR RATIO	TORQUE															
		1/5	1/10	1/12.5	1/15	1/18	1/25	1/30	1/50	1/75	1/100	1/150	1/200	1/300	1/500	1/750	1/1000
TG-21Q-BE (24V)	SPEED (r/min)	874	434	341	287	240	178	142	86	58.7	44.8	30.4	23	15.3	9.2	6.2	4.6
	TORQUE (mN·m)	107.8	196	294	294	343	490	637	980	980	980	980	980	980	980	980	980
	TORQUE (kgf·cm)	1.1	2	3	3	3.5	5	6.5	10	10	10	10	10	10	10	10	10
TG-21R-BE (12V)	SPEED (r/min)	1135	564	444	372	311	232	185	112	76.4	58.3	39.5	29.9	19.9	12	8	6
	TORQUE (mN·m)	107.8	196	294	294	343	490	637	980	980	980	980	980	980	980	980	980
	TORQUE (kgf·cm)	1.1	2	3	3	3.5	5	6.5	10	10	10	10	10	10	10	10	10

BE

GEAR RATIO	STAGE	TORQUE		WEIGHT (g)
		(mN·m)	(kgf·cm)	
1/3 ~ 1/12.5	2	980	10	255
1/15 ~ 1/60	3	980	10	270
1/75 ~ 1/250	4	980	10	285
1/300 ~ 1/1000	5	980	10	300

BM

TG-21Q
TG-21R

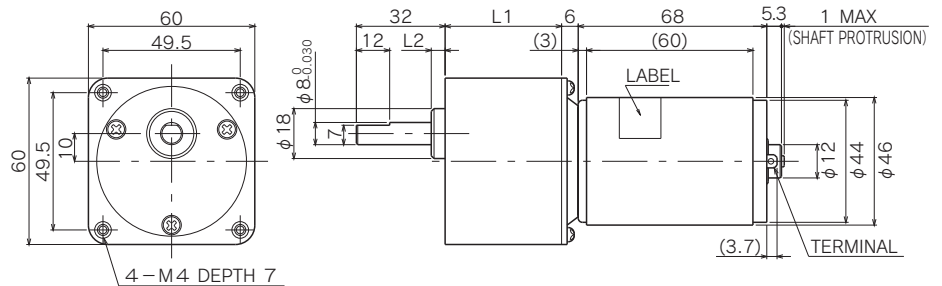

Allowable torque-speed characteristics

BM

MODEL	GEAR RATIO	TORQUE														
		1/5	1/10	1/12.5	1/18	1/25	1/30	1/50	1/75	1/100	1/120	1/150	1/180			
TG-21Q-BM (24V)	SPEED (r/min)	854	434	341	240	172	142	86	57.1	42.8	35.6	28.9	26.1			
	TORQUE (mN·m)	117.6	196	294	343	490	637	980	1372	1862	2254	2450	2450			
	TORQUE (kgf·cm)	1.2	2	3	3.5	5	6.5	10	14	19	23	25	25			
TG-21R-BM (12V)	SPEED (r/min)	1109	564	444	311	223	185	112	74.2	55.6	46.3	37.5	33.9			
	TORQUE (mN·m)	117.6	196	294	343	490	637	980	1372	1862	2254	2450	2450			
	TORQUE (kgf·cm)	1.2	2	3	3.5	5	6.5	10	14	19	23	25	25			

BM

GEAR RATIO	L1 (mm)	L2 (mm)	STAGE	TORQUE		WEIGHT (g)
				(mN·m)	(kgf·cm)	
1/3 ~ 1/15	32	3	2	1470	15	310
1/18 ~ 1/60	42	5	3	2450	25	400
1/75 ~ 1/180	42	5	4	2450	25	430

TG-77

(26W) $\phi 63$, 12-SLOT,
HIGH-POWER.

BM

TG-77A

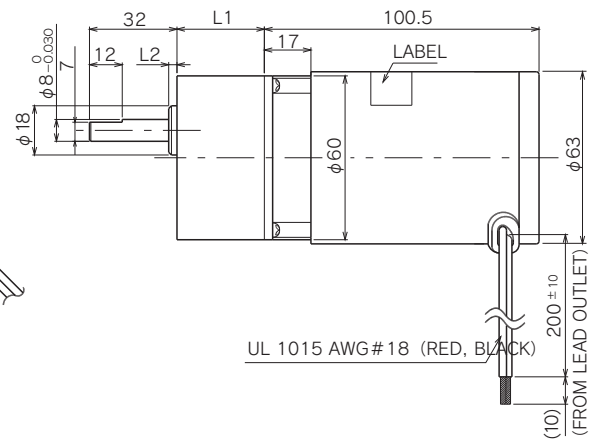
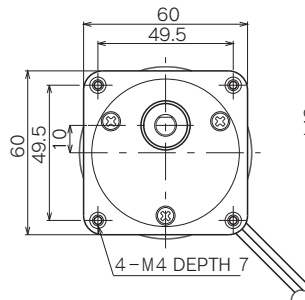

Allowable torque-speed characteristics **BM**

MODEL	GEAR RATIO	1	1	1	1	1	1	1	1	1	1	1	1
		5	10	12.5	18	25	30	50	75	100	120	150	180
TG-77A-BM (24V)	SPEED (r/min)	501	250	200	139	100	83.8	52.4	35.9	27.4	23.1	18.6	16.7
	TORQUE (mN·m)	392	784	980	1274	1764	2058	2450	2450	2450	2450	2450	2450
	TORQUE (kgf·cm)	4	8	10	13	18	21	25	25	25	25	25	25

BM

GEAR RATIO	L1 (mm)	L2 (mm)	STAGE	TORQUE		WEIGHT (g)
				(mN·m)	(kgf·cm)	
1/3 ~ 1/15	32	3	2	1470	15	310
1/18 ~ 1/60	42	5	3	2450	25	400
1/75 ~ 1/180	42	5	4	2450	25	430

TG-78

(46W) $\phi 71$, 12-SLOT,
HIGH-POWER.

JM

TG-78A

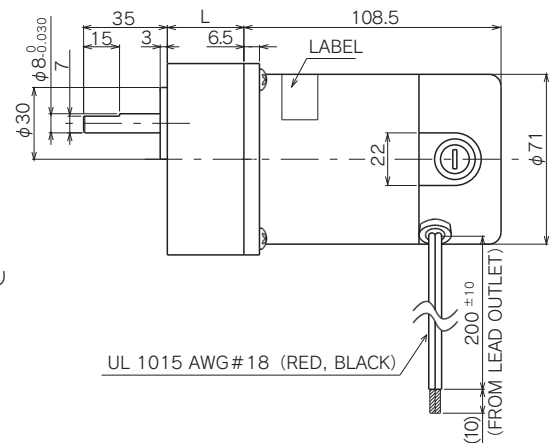
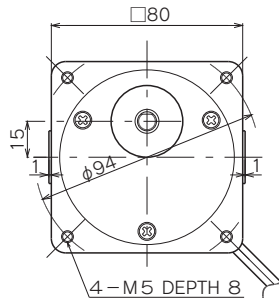

Allowable torque-speed characteristics **JM**

MODEL	GEAR RATIO	1	1	1	1	1	1	1	1	1	1	1	1	1	1	1	1	1			
		5	6	7.5	9	10	12.5	15	18	20	25	30	36	50	60	75	90	100	120	150	180
TG-78A-JM (24V)	SPEED (r/min)	609	521	427	362	304	236	203	174	150	124	106	87.6	62	52.8	42.8	36.2	32.9	27.7	22.5	18.9
	TORQUE (mN·m)	490	490	490	490	980	1470	1470	1470	1960	1960	1960	2450	3920	3920	3920	3920	3920	3920	3920	3920
	TORQUE (kgf·cm)	5	5	5	5	10	15	15	15	20	20	20	25	40	40	40	40	40	40	40	40

JM

GEAR RATIO	L (mm)	STAGE	TORQUE		WEIGHT (g)
			(mN·m)	(kgf·cm)	
1/5 ~ 1/9	32	2	490	5	500
1/10	32	2	980	10	500
1/12.5 ~ 1/18	32	2	1470	15	500
1/20 ~ 1/30	42.5	3	1960	20	650
1/36	42.5	3	2450	25	650
1/50 ~ 1/60	42.5	3	3920	40	650
1/75 ~ 1/180	42.5	4	3920	40	750

TG-22

(2.6W) 22-SQUARE,
COMPACT INNER ROTOR TYPE.

Motor Driver Circuit for TG-22

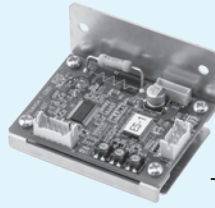

TCP-S27A-22A

Single motor specification

TYPE	RATED VOLTAGE (V)	NO-LOAD SPEED (r/min)	NO-LOAD CURRENT (mA)	TORQUE		RATED SPEED (r/min)	RATED CURRENT (mA)	DIRECTION OF ROTATION	WEIGHT (g)
				(mN · m)	(gf · cm)				
TG-22A	24	5250	54	5.88	60	4270	190	BOTH DIRECTIONS	95
TG-22D	12	5250	100	5.88	60	4270	380	BOTH DIRECTIONS	95

Single motor outline

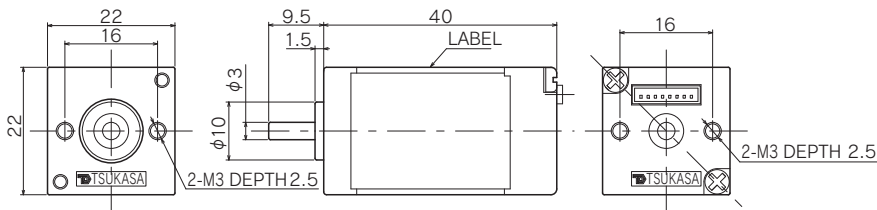

Motor Internal Connection Diagram

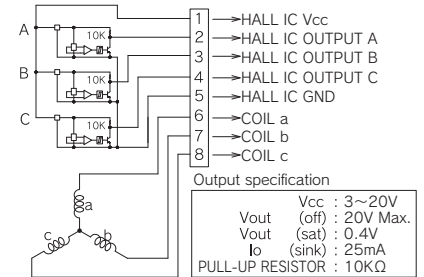

FU

TG-22A
TG-22D

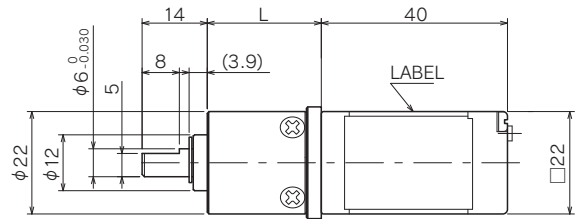
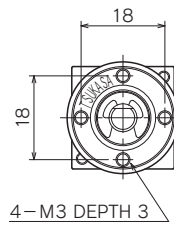

Allowable torque-speed characteristics

FU

MODEL	GEAR RATIO	1	1	1	1
		4	16	64	256
TG-22A-FU (24V)	SPEED (r/min)	1026	257	67	18.5
	TORQUE (mN·m)	19.6	68.6	196	294
	TORQUE (kgf·cm)	0.2	0.7	2	3
TG-22D-FU (12V)	SPEED (r/min)	1026	257	67	18.5
	TORQUE (mN·m)	19.6	68.6	196	294
	TORQUE (kgf·cm)	0.2	0.7	2	3

FU

GEAR RATIO	L (mm)	STAGE	TORQUE		WEIGHT (g)
			(mN·m)	(kgf·cm)	
1/4	19.5	1	49	0.5	41
1/16	24.5	2	98	1	49
1/64	29.5	3	196	2	57
1/256	34.5	4	294	3	66

TG-611

(3.5W) 22-SQUARE, COMPACT INNER ROTOR TYPE BRUSHLESS MOTOR.

Motor Driver Circuit for TG-611

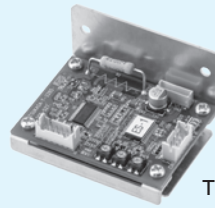

TCP-S27A-611B

Single motor specification

TYPE	RATED VOLTAGE (V)	NO-LOAD SPEED (r/min)	NO-LOAD CURRENT (mA)	TORQUE		RATED SPEED (r/min)	RATED CURRENT (mA)	DIRECTION OF ROTATION	WEIGHT (g)
				(mN·m)	(gf·cm)				
TG-611B	24	7260	80	5.88	60	5700	280	BOTH DIRECTIONS	61

Single motor outline

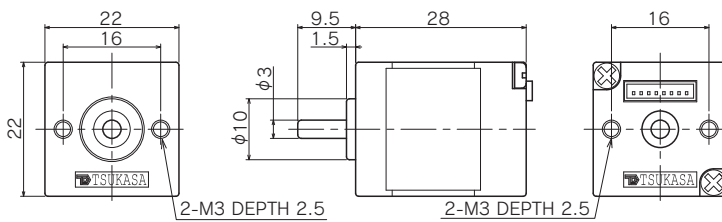

Motor Internal Connection Diagram

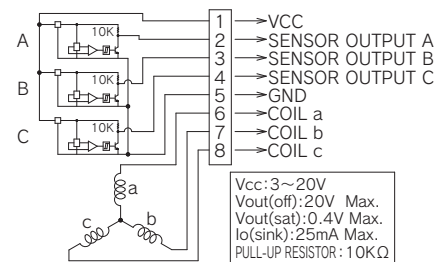

FU

TG-611B

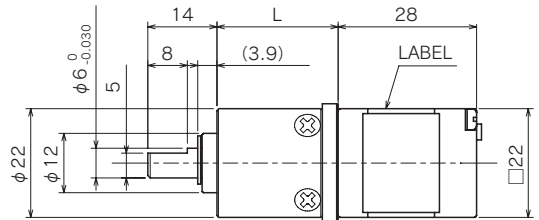
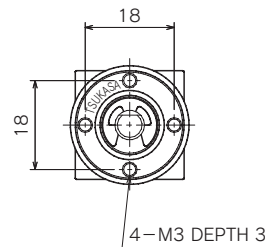

Allowable torque-speed characteristics

FU

MODEL	GEAR RATIO	1	1	1	1
		4	16	64	256
TG-611B-FU (24V)	SPEED (r/min)	1380	345	90.8	25.5
	TORQUE (mN·m)	19.6	68.6	196	294
	TORQUE (kgf·cm)	0.2	0.7	2	3

FU

GEAR RATIO	L (mm)	STAGE	TORQUE		WEIGHT (g)
			(mN·m)	(kgf·cm)	
1/4	19.5	1	49	0.5	41
1/16	24.5	2	98	1	49
1/64	29.5	3	196	2	57
1/256	34.5	4	294	3	66

TG-55

(1.6 ~ 8.8W) LONG-LIFE, INNER ROTOR, COMPACT 3-PHASE BRUSHLESS MOTOR.

Motor Driver Circuit for TG-55

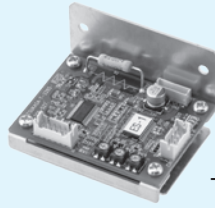

TCP-S27A-55N

Single motor specification

TYPE	RATED VOLTAGE (V)	NO-LOAD SPEED (r/min)	NO-LOAD CURRENT (mA)	TORQUE		RATED SPEED (r/min)	RATED CURRENT (mA)	DIRECTION OF ROTATION	WEIGHT (g)
				(mN·m)	(gf·cm)				
TG-55L	24	3900	85	19.6	200	2650	420	BOTH DIRECTIONS	160
TG-55L	12	1830	65	19.6	200	700	420	BOTH DIRECTIONS	160
TG-55M	24	6700	140	14.7	150	5450	570	BOTH DIRECTIONS	160
TG-55M	12	3240	115	14.7	150	2150	560	BOTH DIRECTIONS	160
TG-55N	24	8400	170	9.8	100	7350	540	BOTH DIRECTIONS	160
TG-55N	12	4090	140	9.8	100	3120	510	BOTH DIRECTIONS	160

Single motor outline

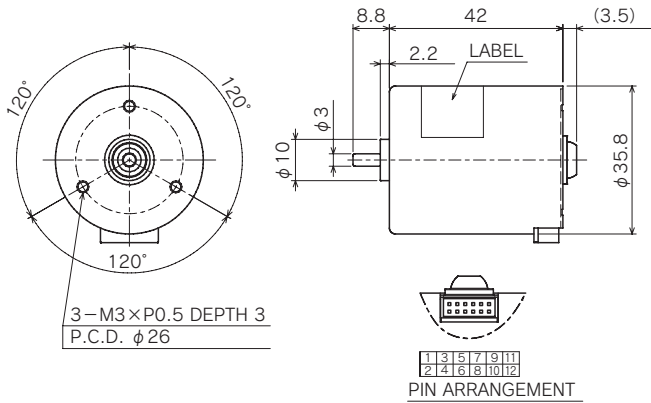

Motor Internal Connection Diagram

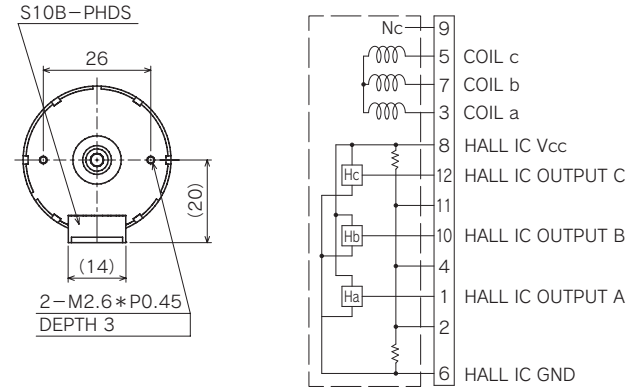

SU

TG-55L
TG-55M
TG-55N

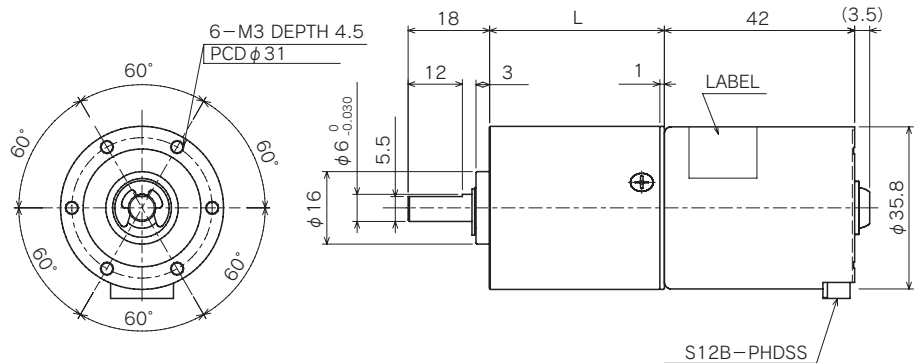

Allowable torque-speed characteristics

SU

MODEL	GEAR RATIO	SU													
		1/3.6	1/4.8	1/13.2	1/17.6	1/23.5	1/47.9	1/63.9	1/85.3	1/114	1/174	1/232	1/310	1/413	1/552
TG-55L-SU (24V)	SPEED (r/min)	672	479	188	135	101	49.1	36.5	31.0	25.2	17.2	13.6	10.5	8.0	6.1
	TORQUE (mN·m)	58.8	88.2	196	294	392	686	980	980	980	980	980	980	980	980
	TORQUE (kgf·cm)	0.6	0.9	2	3	4	7	10	10	10	10	10	10	10	10
TG-55L-SU (12V)	SPEED (r/min)	154	92.8	44.7	28.1	21.1	10.0	7.2	8.7	8.3	6.1	5.2	4.2	3.3	2.5
	TORQUE (mN·m)	58.8	88.2	196	294	392	686	980	980	980	980	980	980	980	980
	TORQUE (kgf·cm)	0.6	0.9	2	3	4	7	10	10	10	10	10	10	10	10
TG-55M-SU (24V)	SPEED (r/min)	1357	1045	375	290	212	105	77.3	58.1	46.2	31.2	24.4	18.7	14.2	10.8
	TORQUE (mN·m)	49	58.8	166.6	196	294	490	735	980	980	980	980	980	980	980
	TORQUE (kgf·cm)	0.5	0.6	1.7	2	3	5	7.5	10	10	10	10	10	10	10
TG-55M-SU (12V)	SPEED (r/min)	485	387	134	109	76.8	38.4	27.7	20.9	17.9	12.6	10.3	8.1	6.2	4.8
	TORQUE (mN·m)	49	58.8	166.6	196	294	490	735	980	980	980	980	980	980	980
	TORQUE (kgf·cm)	0.5	0.6	1.7	2	3	5	7.5	10	10	10	10	10	10	10
TG-55N-SU (24V)	SPEED (r/min)	1862	1397	508	381	285	140	104	78.6	58.6	39.0	30.5	23.3	17.7	13.5
	TORQUE (mN·m)	29.4	39.2	107.8	147	196	343	490	637	882	980	980	980	980	980
	TORQUE (kgf·cm)	0.3	0.4	1.1	1.5	2	3.5	5	6.5	9	10	10	10	10	10
TG-55N-SU (12V)	SPEED (r/min)	730	549	197	147	110	53.9	40.1	30.5	22.5	15.3	12.6	9.9	7.7	5.9
	TORQUE (mN·m)	29.4	39.2	107.8	147	196	343	490	637	882	980	980	980	980	980
	TORQUE (kgf·cm)	0.3	0.4	1.1	1.5	2	3.5	5	6.5	9	10	10	10	10	10

SU

GEAR RATIO	L (mm)	STAGE	TORQUE		WEIGHT (g)
			(mN·m)	(kgf·cm)	
1/3.6 ~ 1/4.8	23.5	1	294	3	120
1/13.2 ~ 1/23.5	31.6	2	588	6	160
1/47.9 ~ 1/114	38.6	3	980	10	195
1/174 ~ 1/552	45.7	4	980	10	235

SM

TG-55L
TG-55M
TG-55N

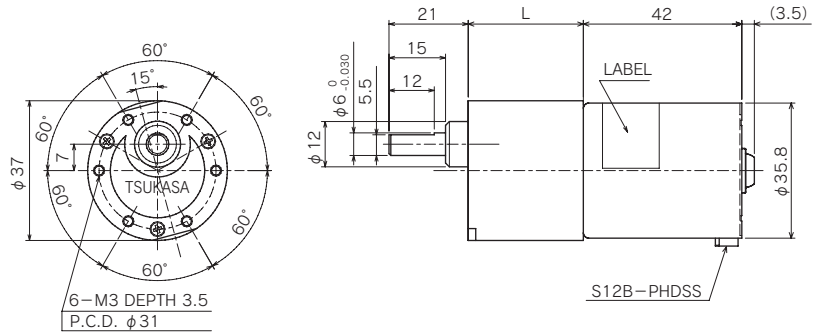

Allowable torque-speed characteristics SM

MODEL	GEAR RATIO	1																		
		5	10	15	18	25	30	36	50	60	75	100	120	150	200	250	300	500	750	1000
TG-55L-SM (24V)	SPEED (r/min)	522	307	180	160	126	109	84.6	65.2	55.9	46.0	35.4	27.5	22.7	17.6	14.3	12.0	7.4	5.0	3.8
	TORQUE (mN·m)	78.4	98	196	196	196	196	294	294	294	294	294	588	588	588	588	588	588	588	588
	TORQUE (kgf·cm)	0.8	1	2	2	2	2	3	3	3	3	3	6	6	6	6	6	6	6	6
TG-55L-SM (12V)	SPEED (r/min)	140	111	52.0	52.7	47.4	42.9	30.3	25.7	22.9	19.4	15.4	11.0	9.5	7.6	6.3	5.4	3.3	2.3	1.7
	TORQUE (mN·m)	78.4	98	196	196	196	196	294	294	294	294	294	588	588	588	588	588	588	588	588
	TORQUE (kgf·cm)	0.8	1	2	2	2	2	3	3	3	3	3	6	6	6	6	6	6	6	6
TG-55M-SM (24V)	SPEED (r/min)	1071	556	358	299	227	194	154	116	99.1	80.9	61.9	49.0	40.1	30.8	24.9	21.0	12.8	8.6	6.5
	TORQUE (mN·m)	58.8	98	156.8	186.2	196	196	294	294	294	294	294	588	588	588	588	588	588	588	588
	TORQUE (kgf·cm)	0.6	1	1.6	1.9	2	2	3	3	3	3	3	6	6	6	6	6	6	6	6
TG-55M-SM (12V)	SPEED (r/min)	424	230	142	119	95.7	84.1	63.1	50.5	43.9	36.5	28.5	21.4	18.0	14.1	11.5	9.8	6.0	4.1	3.1
	TORQUE (mN·m)	58.8	98	156.8	186.2	196	196	294	294	294	294	294	588	588	588	588	588	588	588	588
	TORQUE (kgf·cm)	0.6	1	1.6	1.9	2	2	3	3	3	3	3	6	6	6	6	6	6	6	6
TG-55N-SM (24V)	SPEED (r/min)	1443	722	486	401	289	243	204	146	124	101	77.6	61.3	50.2	38.5	31.3	26.3	16.0	10.8	8.1
	TORQUE (mN·m)	39.2	78.4	98	127.4	176.4	196	196	294	294	294	294	588	588	588	588	588	588	588	588
	TORQUE (kgf·cm)	0.4	0.8	1	1.3	1.8	2	2	3	3	3	3	6	6	6	6	6	6	6	6
TG-55N-SM (12V)	SPEED (r/min)	614	307	209	170	123	105	89.0	62.8	54.7	45.7	35.7	26.7	22.4	17.6	14.5	12.3	7.6	5.2	3.9
	TORQUE (mN·m)	39.2	78.4	98	127.4	176.4	196	196	294	294	294	294	588	588	588	588	588	588	588	588
	TORQUE (kgf·cm)	0.4	0.8	1	1.3	1.8	2	2	3	3	3	3	6	6	6	6	6	6	6	6

SM

GEAR RATIO	L (mm)	STAGE	TORQUE		WEIGHT (g)
			(mN·m)	(kgf·cm)	
1/5 ~ 1/10	23	2	98	1	100
1/12.5 ~ 1/30	25.5	3	196	2	105
1/36 ~ 1/100	28	4	294	3	110
1/120 ~ 1/300	30.5	5	588	6	115
1/360 ~ 1/1000	33	6	588	6	120

AP

TG-55L
TG-55M
TG-55N

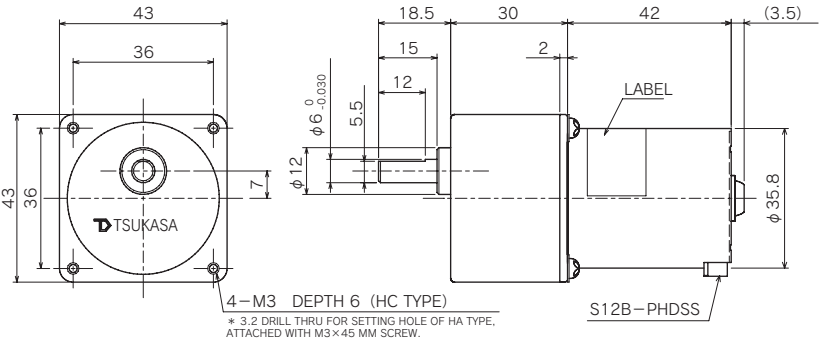

Allowable torque-speed characteristics AP

MODEL	GEAR RATIO	1														
		6	8	13	16	20	27	32	43	53	67	81	89	108	133	
TG-55L-AP (24V)	SPEED (r/min)	444	361	207	183	147	107	86.5	65.2	54.3	42.3	35.3	33.1	28.7	24.3	
	TORQUE (mN·m)	98	98	196	196	245	343	441	539	637	833	980	980	980	980	
	TORQUE (kgf·cm)	1	1	2	2	2.5	3.5	4.5	5.5	6.5	8.5	10	10	10	10	
TG-55L-AP (12V)	SPEED (r/min)	124	125	59	60.1	48.1	34.4	26.7	20.6	17.4	13.3	11.3	11.2	10.5	9.5	
	TORQUE (mN·m)	98	98	196	196	245	343	441	539	637	833	980	980	980	980	
	TORQUE (kgf·cm)	1	1	2	2	2.5	3.5	4.5	5.5	6.5	8.5	10	10	10	10	
TG-55M-AP (24V)	SPEED (r/min)	914	660	412	342	285	205	166	124	102	80.8	66.9	60.6	52	43.4	
	TORQUE (mN·m)	68.6	98	156.8	186.2	196	294	392	490	588	735	882	980	980	980	
	TORQUE (kgf·cm)	0.7	1	1.6	1.9	2	3	4	5	6	7.5	9	10	10	10	
TG-55M-AP (12V)	SPEED (r/min)	372	266	163	136	118	82.9	65.4	49	40.6	32.2	26.7	24.2	21.6	18.7	
	TORQUE (mN·m)	68.6	0	156.8	186.2	196	294	392	490	588	735	882	980	980	980	
	TORQUE (kgf·cm)	0.7	1	1.6	1.9	2	3	4	5	6	7.5	9	10	10	10	
TG-55N-AP (24V)	SPEED (r/min)	1210	878	560	458	370	274	225	169	138	109	89.8	81.8	67.4	54.3	
	TORQUE (mN·m)	49	68.6	98	127.4	127.4	196	245	294	392	490	588	637	784	980	
	TORQUE (kgf·cm)	0.5	0.7	1	1.3	1.3	2	2.5	3	4	5	6	6.5	8	10	
TG-55N-AP (12V)	SPEED (r/min)	518	375	241	194	157	118	96.6	73.1	58.7	46.4	38.4	35.1	28.8	23.2	
	TORQUE (mN·m)	49	68.6	98	127.4	156.8	196	245	294	392	490	588	637	784	980	
	TORQUE (kgf·cm)	0.5	0.7	1	1.3	1.6	2	2.5	3	4	5	6	6.5	8	10	

AP

GEAR RATIO	STAGE	TORQUE		WEIGHT (g)
		(mN·m)	(kgf·cm)	
1/6 ~ 1/8	2	98	1	205
1/13 ~ 1/16	3	196	2	220
1/20	3	245	2.5	220
1/27	3	343	3.5	220
1/32	3	441	4.5	220
1/43	4	539	5.5	235
1/53	4	637	6.5	235
1/67	4	833	8.5	235
1/81 ~ 1/133	4	980	10	235

TG-609

φ42 HIGH POWER BRUSHLESS MOTOR.

Motor Driver Circuit for TG-609

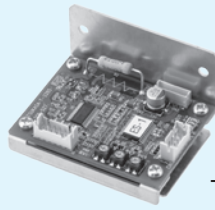

TCP-S27A-609

APPLICATION

LASER PRINTER / COPIER / SORTER / TICKET-VENDING MACHINE / BUS FARE BOX / ATM / GAMING MACHINE / SECURITY CAMERA / BILL BINDING MACHINE / MONEY COUNTING MACHINE / VENDING MACHINE / PRINTING PRESS etc.

Single motor specification

TYPE	RATED VOLTAGE (V)	NO-LOAD SPEED (r/min)	NO-LOAD CURRENT (mA)	TORQUE		RATED SPEED (r/min)	RATED CURRENT (mA)	DIRECTION OF ROTATION	WEIGHT (g)
				(mN · m)	(gf · cm)				
TG-609A	24	3910	230	78.4	800	2870	1425	BOTH DIRECTIONS	300
TG-609B	24	3950	300	78.4	800	3270	1475	BOTH DIRECTIONS	300
TG-609C	24	3950	300	78	800	3270	1475	BOTH DIRECTIONS	300

*TG-609C is only for BM gear.

Single motor outline

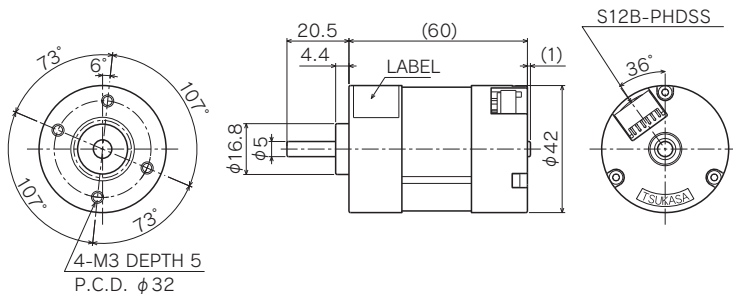

Motor Internal Connection Diagram

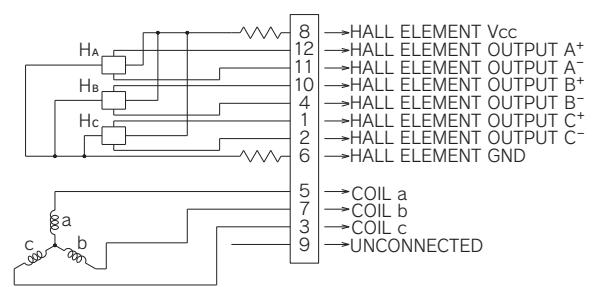

BM

TG-609C

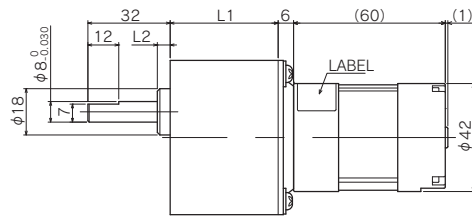
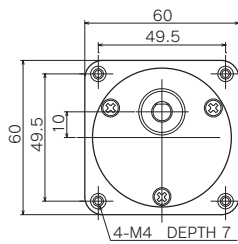

GEAR HEAD: BALL BEARING SPECIFICATION

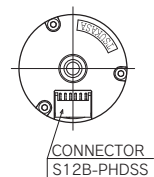

CONNECTOR S12B-PHDSS

Allowable torque-speed characteristics

BM

MODEL	GEAR RATIO	1	1	1	1	1	1	1
		5	10	18	30	50	100	180
TG-609C-BM (24V)	SPEED (r/min)	651	325	180	107	66	35.5	22
	TORQUE (mN · m)	294	588	980	1666	2450	2450	2450
	TORQUE (kgf · cm)	3	6	10	17	25	25	25

BM

GEAR RATIO	L1 (mm)	L2 (mm)	STAGE	TORQUE		WEIGHT (g)		
				(mN · m)	(kgf · cm)			
1/5	32	3	2	0.29	3	230		
1/10				0.98	10			
1/18				1.47	15			
1/30	42	5	3	1.96	20	320		
1/50				2.45	25			
1/100				2.45	25		4	340
1/180								350

TCP-S27A

BRUSHLESS MOTOR DRIVER.

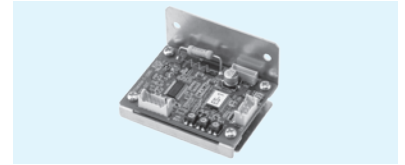

55N 22D 22A 611B

External dimensions, part names

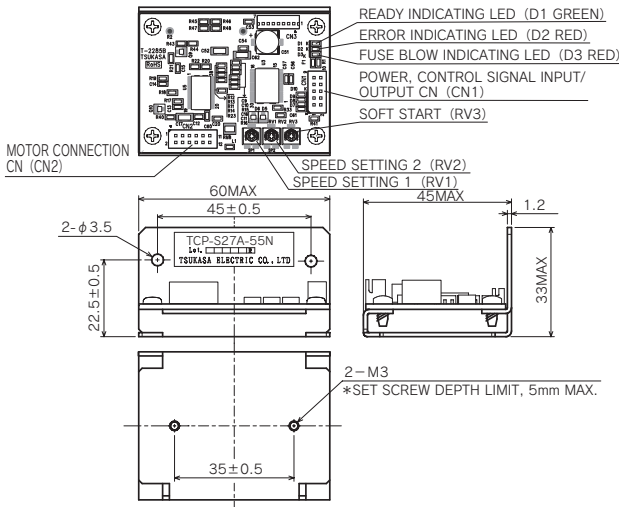

Specification

DRIVER MODEL		TCP-S27A-55N		TCP-S27A-22D	TCP-S27A-22A	TCP-S27A-611B
APPLICABLE MOTOR	MODEL	TG-55L	TG-55M	TG-22D	TG-22A	TG-611B
	MAGNETIC POLE SENSOR	HALL IC (RECTANGULAR WAVE OUTPUT)				
SUPPLY VOLTAGE		WITHIN 24 VDC ±10%		WITHIN 12 VDC ±10%	WITHIN 24 VDC ±10%	
CONTROL CIRCUIT CONSUMPTION POWER		1W MAX.				
RATED OUTPUT CURRENT ^{※1}		450mA	600mA	380mA	190mA	280mA
OVERLOAD DETERMINATION CURRENT		650mA		460mA	230mA	340mA
CURRENT LIMITING VALUE		3.3A		2.2A		
PWM FREQUENCY		APPROX. 20.0KHz				
SPEED VARIABLE RANGE ^{※2}		200 ~ 3700rpm	200 ~ 6350rpm	200 ~ 8000rpm	200 ~ 4900rpm	200 ~ 6900rpm
EXTERNAL SPEED COMMAND COEFFICIENT		1800rpm/V ±5%		1200rpm/V ±5%	1500rpm/V ±5%	
SPEED SETTING (ROTATIONAL SPEED SETTING)		DRIVER INTERNAL SETTING : 2 LINES OF RV1 AND RV2 (CHANGEABLE BY SPEED CHANGE INPUT) EXTERNAL SPEED COMMAND INPUT : 1 LINE				
SOFT START SETTING ^{※4}		SETTABLE TO MAX. 1.67 sec/1000 rpm BY RV3. OPERATION AT START AND SPEED COMMAND SPEEDUP (D1 FLICKERS AT OPERATION.)				
SIGNAL INPUT		START INPUT, ROTATIONAL DIRECTION CHANGE INPUT, BRAKE SELECT INPUT, SPEED CHANGE INPUT, EXTERNAL SPEED COMMAND INPUT				
SIGNAL OUTPUT		ROTATION SYNCHRONOUS SIGNAL OUTPUT, ALARM OUTPUT				
PROTECT FUNCTION ^{※5}	OVERLOAD	INTERRUPTS OUTPUT WHEN CURRENT EXCEEDING RATED OUTPUT CURRENT FLOWS CONTINUOUSLY (STATUS HOLD). RESET AT START INPUT "OPEN" AND ANOTHER POWER ON.				
	SENSOR ALARM	INTERRUPTS OUTPUT ON DETECTING ALARM CODE OF SENSOR SIGNAL (STATUS HOLD). RESET AT START INPUT "OPEN" AND ANOTHER POWER ON.				
	MOTOR LOCK	INTERRUPTS OUTPUT ON DETECTING MOTOR LOCKING (STATE HOLD). DETECTS THE STOP FOR 2 SEC OR MORE AND MAKES A JUDGMENT OF LOCK WHEN MOTOR CURRENT OF 0.5 A OR OVER FLOWS AT 250 rpm OR OVER OF SPEED COMMAND VALUE. RESET AT START INPUT "OPEN" AND ANOTHER POWER ON.		INTERRUPTS OUTPUT ON DETECTING MOTOR LOCKING (STATE HOLD). DETECTS THE STOP FOR 2 SEC OR MORE AND MAKES A JUDGMENT OF LOCK WHEN MOTOR CURRENT OF 0.2 A OR OVER FLOWS AT 250 rpm OR OVER OF SPEED COMMAND VALUE. RESET AT START INPUT "OPEN" AND ANOTHER POWER ON.		
	SUPPLY VOLTAGE DROP	INTERRUPTS OUTPUT ON DETECTING SUPPLY VOLTAGE DROP (AUTOMATIC RESET).				
	OVERCURRENT	INTERRUPTS OUTPUT ON DETECTING ABNORMAL MOTOR CURRENT (AUTOMATIC RESET).				
	FUSE PROTECT	INTERRUPTS CIRCUIT ON DETECTING ABNORMAL POWER CURRENT. F1 (5 A CHIP FUSE).				
WORK ENVIRONMENT		0 ~ 40°C, 85% RH MAX. (NO DEW ALLOWED.) USED IN ATMOSPHERE SUBJECT TO HEAT CONVECTION.				
STORAGE ENVIRONMENT		-10 ~ 60°C, 85% MAX. (NO DEW ALLOWED.)				
ACCESSORY		MOTOR CONNECTION CABLE X1 POWER/CONTROL SIGNAL INPUT/OUTPUT CABLE X1				
WEIGHT		APPROX. 30g (BODY ONLY)				

- ※1 : The rated output current is continuous allowable current value when the applicable motor is combined, and it is not possible to continuously run the motor exceeding this value.
- ※2 : The maximum value in the variable speed range is proportional to power voltage. The noted value, the no load rotational speed when the specified supply voltage is inputted, contains the error of ±10%.
- ※3 : This driver cannot be used for the application where a minus load such as electric power load applies. Turning the motor shaft from the load side or driving a load of big moment of inertia may cause overvoltage by regenerative energy of the motor possibly damaging the driver circuit or the device connected with the same power supply.
Check that there is no overvoltage by regenerative energy at commissioning.
- ※4 : Soft start function is not activated in deceleration but in acceleration.
- ※5 : Be sure to eliminate the cause of activation of overload and wait that motor and driver temperatures lower before resetting the driver. In the case of motor line short-circuit or ground fault, the driver may stop the motor at overload or motor lock error on detecting the overcurrent. The error LED lights when the overload judgment current is exceeded during normal operation. Use this as a guide to judge the state of load. Replacement or repair is necessary when the fuse blows. Please contact the supplier for inspection or repair.

Reference connection diagram

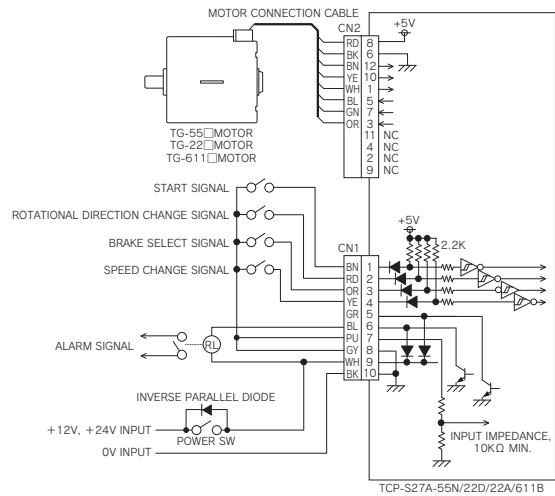

Input/output signal, each display and content of setting

NAME, PIN No.	CABLE COLOR	SIGNAL NAME	CONTENT
CN1 (POWER, CONTROL SIGNAL INPUT/OUTPUT)	1	BN	START INPUT "H" : STOP, ALARM RESET "L" : ROTATION OPERATION
	2	RD	ROTATIONAL DIRECTION CHANGE INPUT ^{※7} "H" : CW ROTATION "L" : CCW ROTATION
	3	OR	BRAKE SELECT INPUT SELECT THE STOP METHOD WHEN START INPUT IS CHANGED TO "H" "H" : FREE RUN STOP SELECT "L" : BRAKE STOP SELECT
	4	YE	SPEED CHANGE INPUT "H" : RV1 SELECT "L" : RV2 SELECT
	5	GR	ROTATION SYNCHRONOUS SIGNAL OUTPUT OUTPUTS PULSE SIGNAL SYNCHRONIZED WITH ROTATION (6 PULSES/ROTATION).
	6	BL	ALARM OUTPUT OUTPUT ON DETECTING OVERLOAD, SENSOR ALARM OR OVERCURRENT TRANSISTOR ON OUTPUT TRANSISTOR OFF WHEN NORMAL
	7	PU	EXTERNAL SPEED COMMAND INPUT ^{※8} INPUT VOLTAGE : 0 ~ 5V (12V MAX.) INPUT IMPEDANCE : 10kΩ OR OVER
	8	GY	GND CONTROL INPUT SIGNAL GROUND (SAME POTENTIAL AS CN1-10)
	9	WH	POWER INPUT +12V, +24 V INPUT 0V INPUT (SAME POTENTIAL AS CN1-8)
	10	BK	
CN2 (MOTOR SIGNAL INPUT/OUTPUT)	8	RD	+5V 5V OUTPUT FOR MAGNETIC POLE SENSOR (NOT USABLE FOR OTHER PURPOSES)
	6	BK	GND GND FOR MAGNETIC POLE SENSOR
	12	BN	SENSOR SIGNAL INPUT A-PHASE SENSOR SIGNAL B-PHASE SENSOR SIGNAL C-PHASE SENSOR SIGNAL
	10	YE	
	1	WH	
	5	BL	MOTOR OUTPUT A-PHASE COIL B-PHASE COIL C-PHASE COIL
	7	GN	
	3	OR	
	11	—	NC NOT USED
	4	—	
2	—		
9	—		
—	—		
STATE INDICATING LED		READY INDICATING LED (D1 : GREEN)	READY STATE (DRIVABLE STATE) : ON AT SOFT START OPERATION : FLICKER ON ACTIVATION OF ALARM : OFF
		ERROR INDICATING LED (D2 : RED)	AT NORMAL OPERATION : OFF AT POWER ON RESET : ON (0.5 sec) DETECTING OVERLOAD JUDGE CURRENT OR HIGHER : ON AT SENSOR ALARM : CONTINUOUS ON DETECTING MOTOR LOCKING : FLICKER ONCE DETECTING OVERLOAD : FLICKER TWICE SUPPLY VOLTAGE DROP : D1/D2 LIGHTS ALTERNATELY
		FUSE BLOW LED (D3 RED)	ON AT FUSE BLOWING
ADJUST VR		RV1 ^{※8}	SPEED SETTING SP1 (SET TO 0 SCALE AT SHIPPING)
		RV2 ^{※8}	SPEED SETTING SP2 (SET TO 0 SCALE AT SHIPPING)
		RV3	SOFT START SETTING SOFTWARE (SET TO 0 SCALE AT SHIPPING)

- ※6 : Rotational direction is that with single motor. Refer to the specification for each geared motor for the direction of geared motor output shaft.
- ※7 : For motor rotation, any of the highest setting value from RV1, RV2 or speed command input is given priority. When using the external speed command input, set RV1 and RV2 to 0 scale.
- ※8 : Connect the external speed command input with the GND terminal when using the internal speed setting VR (RV1, 2).

External dimensions, part names

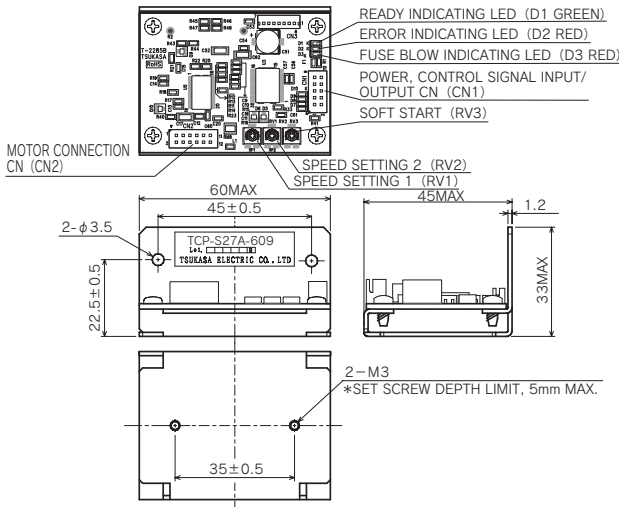

Reference connection diagram

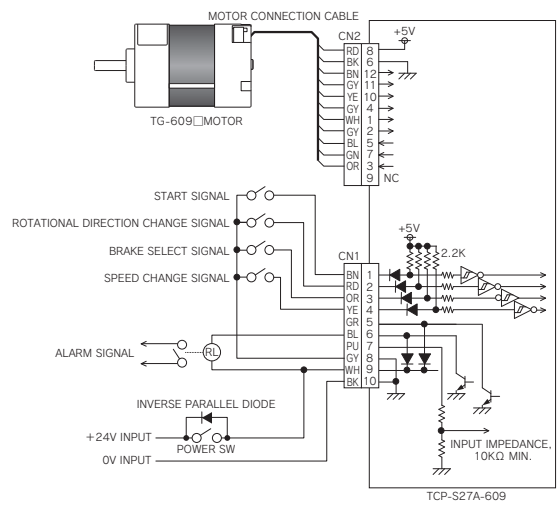

Specification

ITEM		TCP-S27A-609	
APPLICABLE MOTOR	MODEL	TG-609A	TG-609B, TG-609C
	MAGNETIC POLE SENSOR	HALL ELEMENT (ANALOG VOLTAGE OUTPUT)	
SUPPLY VOLTAGE		WITHIN 24 VDC ±10%	
CONTROL CIRCUIT CONSUMPTION POWER		1W MAX.	
RATED OUTPUT CURRENT ^{※1}		1500mA	
OVERLOAD DETERMINATION CURRENT		1650mA	
CURRENT LIMITING VALUE		6.6A	
PWM FREQUENCY		APPROX. 20.0KHz	
SPEED VARIABLE RANGE ^{※2}		100 ~ 3700rpm	100 ~ 3800rpm
EXTERNAL SPEED COMMAND COEFFICIENT		1000rpm/V ±5%	
SPEED SETTING (ROTATIONAL SPEED SETTING)		DRIVER INTERNAL SETTING: 2 LINES OF RV1 AND RV2 (CHANGEABLE BY SPEED CHANGE INPUT) EXTERNAL SPEED COMMAND INPUT: 1 LINE	
SOFT START SETTING ^{※4}		SETTABLE TO MAX. 1.67 sec/1000 rpm BY RV3. OPERATION AT START AND SPEED COMMAND SPEEDUP (D1 FLICKERS AT OPERATION.)	
SIGNAL INPUT		START INPUT, ROTATIONAL DIRECTION CHANGE INPUT, BRAKE SELECT INPUT, SPEED CHANGE INPUT, EXTERNAL SPEED COMMAND INPUT	
SIGNAL OUTPUT		ROTATION SYNCHRONOUS SIGNAL OUTPUT, ALARM OUTPUT	
PROTECT FUNCTION ^{※5}		OVERLOAD : INTERRUPTS OUTPUT WHEN CURRENT EXCEEDING RATED OUTPUT CURRENT FLOWS CONTINUOUSLY (STATUS HOLD). RESET AT START INPUT "OPEN" AND ANOTHER POWER ON.	
		SENSOR ALARM : INTERRUPTS OUTPUT ON DETECTING ALARM CODE OF SENSOR SIGNAL (STATUS HOLD). RESET AT START INPUT "OPEN" AND ANOTHER POWER ON.	
		MOTOR LOCK : INTERRUPTS OUTPUT ON DETECTING MOTOR LOCKING (STATE HOLD). DETECTS THE STOP FOR 2 SEC OR MORE AND MAKES A JUDGMENT OF LOCK WHEN MOTOR CURRENT OF 1 A OR OVER FLOWS AT 250 rpm OR OVER OF SPEED COMMAND VALUE. RESET AT START INPUT "OPEN" AND ANOTHER POWER ON.	
		SUPPLY VOLTAGE DROP : INTERRUPTS OUTPUT ON DETECTING SUPPLY VOLTAGE DROP (AUTOMATIC RESET).	
		OVERCURRENT : INTERRUPTS OUTPUT ON DETECTING ABNORMAL MOTOR CURRENT (AUTOMATIC RESET).	
		FUSE PROTECT : INTERRUPTS CIRCUIT ON DETECTING ABNORMAL POWER CURRENT. F1 (5 A CHIP FUSE).	
WORK ENVIRONMENT		0 ~ 40°C, 85% RH MAX. (NO DEW ALLOWED.) USED IN ATMOSPHERE SUBJECT TO HEAT CONVECTION.	
STORAGE ENVIRONMENT		-10 ~ 60°C, 85% MAX. (NO DEW ALLOWED.)	
ACCESSORY		MOTOR CONNECTION CABLE ×1 POWER/CONTROL SIGNAL INPUT/OUTPUT CABLE ×1	
WEIGHT		APPROX. 30g (BODY ONLY)	

- ※1 : The rated output current is continuous allowable current value when the applicable motor is combined, and it is not possible to continuously run the motor exceeding this value.
- ※2 : The maximum value in the variable speed range is proportional to power voltage. The noted value, the no load rotational speed when the specified supply voltage is inputted, contains the error of ±10%.
- ※3 : This driver cannot be used for the application where a minus load such as electric power load applies. Turning the motor shaft from the load side or driving a load of big moment of inertia may cause overvoltage by regenerative energy of the motor possibly damaging the driver circuit or the device connected with the same power supply. Check that there is no overvoltage by regenerative energy at commissioning.
- ※4 : Soft start function is not activated in deceleration but in acceleration.
- ※5 : Be sure to eliminate the cause of activation of overload and wait that motor and driver temperatures lower before resetting the driver. In the case of motor line short-circuit or ground fault, the driver may stop the motor at overload or motor lock error on detecting the overcurrent. The error LED lights when the overload judgment current is exceeded during normal operation. Use this as a guide to judge the state of load. Replacement or repair is necessary when the fuse blows. Please contact the supplier for inspection or repair.

Input/output signal, each display and content of setting

NAME, PIN No.	CABLE COLOR	SIGNAL NAME	CONTENT
CN1 (POWER, CONTROL SIGNAL INPUT/OUTPUT)	1	BN	START INPUT "H" : STOP, ALARM RESET "L" : ROTATION OPERATION
	2	RD	ROTATIONAL DIRECTION CHANGE INPUT ^{※7} "H" : CW ROTATION "L" : CCW ROTATION
	3	OR	BRAKE SELECT INPUT SELECT THE STOP METHOD WHEN START INPUT IS CHANGED TO "H". "H" : FREE RUN STOP SELECT "L" : BRAKE STOP SELECT
	4	YE	SPEED CHANGE INPUT "H" : RV1 SELECT "L" : RV2 SELECT
	5	GR	ROTATION SYNCHRONOUS SIGNAL OUTPUT OUTPUTS PULSE SIGNAL SYNCHRONIZED WITH ROTATION (12 PULSES/ROTATION).
	6	BL	ALARM OUTPUT OUTPUT ON DETECTING OVERLOAD, SENSOR ALARM OR OVERCURRENT TRANSISTOR ON OUTPUT TRANSISTOR OFF WHEN NORMAL
	7	PU	EXTERNAL SPEED COMMAND INPUT ^{※6} INPUT VOLTAGE : 0 ~ 5V (12V MAX.) INPUT IMPEDANCE : 10kΩ OR OVER
	8	GY	GND
	9	WH	+24 V INPUT
	10	BK	0V INPUT (SAME POTENTIAL AS CN1-8)
CN2 (MOTOR SIGNAL INPUT/OUTPUT)	8	RD	+5V OUTPUT FOR MAGNETIC POLE SENSOR (NOT USABLE FOR OTHER PURPOSES)
	6	BK	GND FOR MAGNETIC POLE SENSOR
	12	BN	+A-PHASE
	11	GY	-A-PHASE
	10	YE	+B-PHASE
	4	GY	-B-PHASE
	1	WH	+C-PHASE
	2	GY	-C-PHASE
	5	BL	A-PHASE COIL
7	GN	B-PHASE COIL	
3	OR	C-PHASE COIL	
9	—	NC	NOT USED
STATE INDICATING LED		READY INDICATING LED (D1 : GREEN)	READY STATE (DRIVABLE STATE) : ON AT SOFT START OPERATION : FLICKER ON ACTIVATION OF ALARM : OFF
		ERROR INDICATING LED (D2 : RED)	AT NORMAL OPERATION : OFF AT POWER ON RESET : ON (0.5 sec) DETECTING OVERLOAD JUDGE CURRENT OR HIGHER : ON AT SENSOR ALARM : CONTINUOUS ON DETECTING MOTOR LOCKING : FLICKER ONCE DETECTING OVERLOAD : FLICKER TWICE
		FUSE BLOW INDICATING LED (D3 : RED)	ON AT FUSE BLOWING
ADJUST VR		RV1 ^{※7}	SPEED SETTING SP1 (SET TO 0 SCALE AT SHIPPING)
		RV2 ^{※7}	SPEED SETTING SP2 (SET TO 0 SCALE AT SHIPPING)
		RV3	SOFT START SETTING SOFTWARE (SET TO 0 SCALE AT SHIPPING)

- ※6 : Rotational direction is that with single motor. Refer to the specification for each geared motor for the direction of geared motor output shaft.
- ※7 : For motor rotation, any of the highest setting value from RV1, RV2 or speed command input is given priority. When using the external speed command input, set RV1 and RV2 to 0 scale. Connect the external speed command input with the GND terminal when using the internal speed setting VR (RV1, 2).

Linear motion unit (LA type)

TG-47-LA

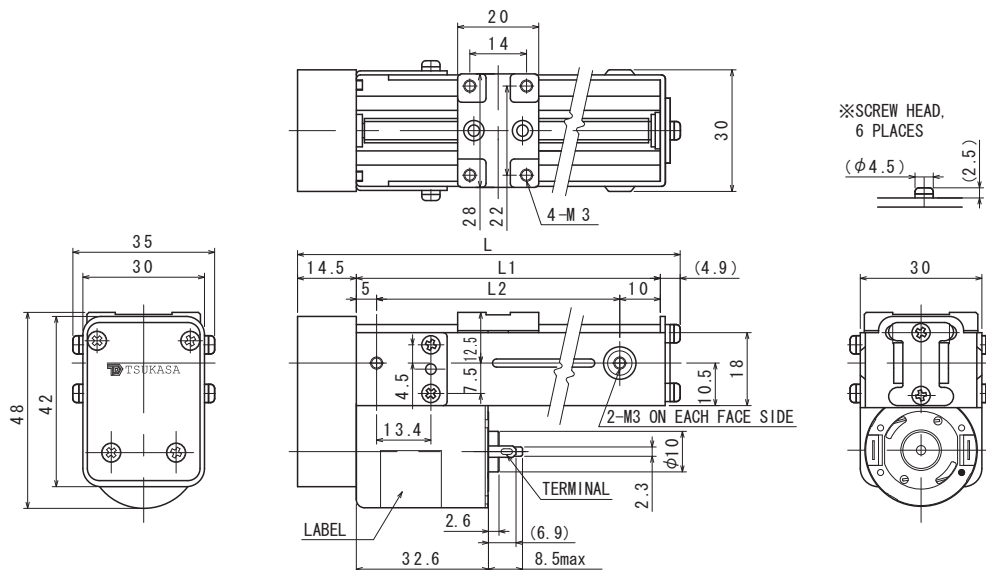

Specification

MOTOR MODEL	47E	47F	47G
WORKING LENGTH [mm]	MAX.50, 75, 100		
PULL FORCE [kgf]	1.0		
SPEED [mm/sec]	12.6	20.4	27.7
RATED CURRENT [mA] (DC24V)	MAX.130	MAX.180	MAX.210

Linear motion unit (LC type)

TG-47-LC

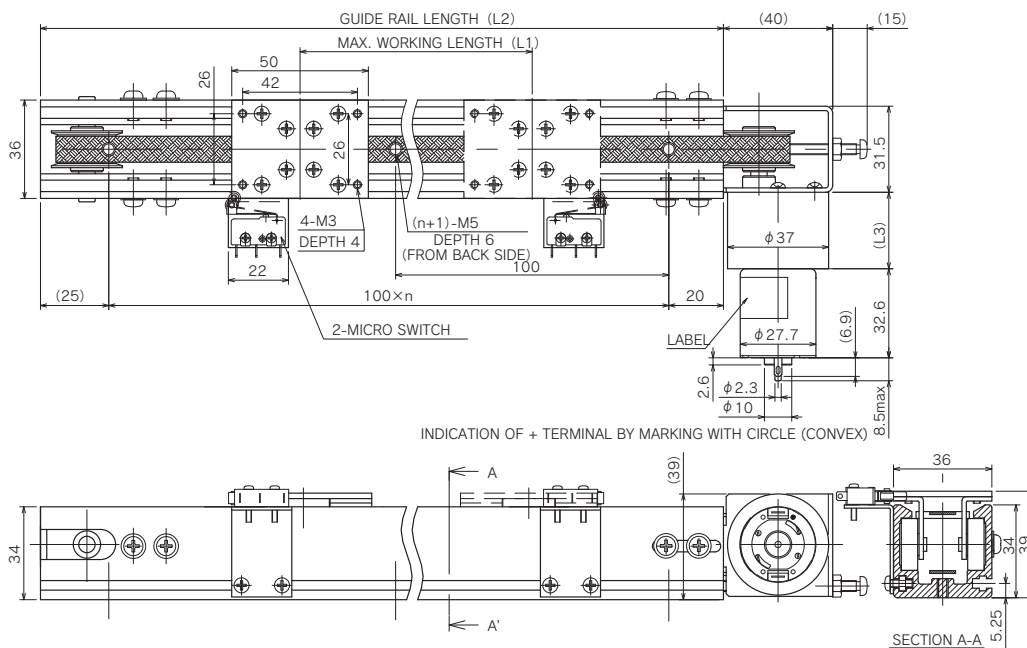

Specification

MOTOR MODEL	47E	47F	47G
WORKING LENGTH [mm]	300, 500, 700*		
PULL FORCE [N] [kgf]	9.8 ~ 39.2 (1.0 ~ 4.0)		
SPEED [mm/sec]	5 ~ 360		

Rotary actuator

MA



Specification

MODEL	MA
VOLTAGE	AC/DC24V ± 10%
WORKABLE RANGE	90°
TORQUE	15N·m (153kgf·cm)
SPEED	90°/60min
MATERIAL	PBT
WEIGHT	1.2kg

180° and 360° type are not standard products.

MB



Specification

MODEL	MB
VOLTAGE	AC/DC24V ± 10%
WORKABLE RANGE	90°
TORQUE	5N·m (51kgf·cm)
SPEED	Under no load: 33 seconds ± 13%/90°, 5N·m: 52 seconds ± 13%/90°
MATERIAL	PBT
WEIGHT	0.5kg

180° and 360° type are not standard products.

Tube pump

H type

APPLICATION

MEDICAL TREATMENT / PHYSICS AND CHEMISTRY / BIOTECHNOLOGY / FUEL CELL etc.



Characteristics / Specification DC24V

FLOW COVER RANGE	0.9 ~ 11ml/min		
FLOW PER ROTATION	0.038ml/r		
APPLICABLE TUBE	P-OLEFIN TUBE S-SILICONE TUBE		
CONNECTING TUBE	INSIDE DIAMETER: ϕ 2mm		
DISCHARGE PRESSURE	0.03MPa		

MODEL	FLOW (ml/min)		
	PT-HP1 (24V)	0.9	4.4
WEIGHT (g)	82	78	78

Setting metal working plan

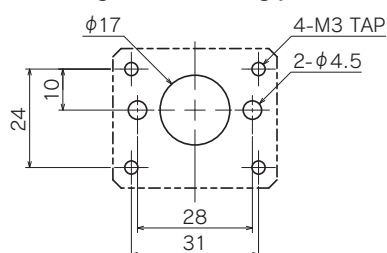

Outline drawing

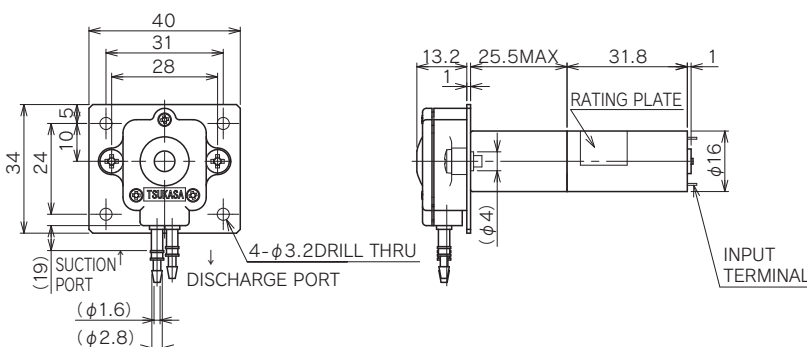

C type

APPLICATION

CLEANING EQUIPMENT / CHEMICAL LIQUID SUPPLYING EQUIPMENT etc.

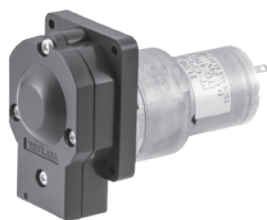

Characteristics / Specification DC24V

FLOW COVER RANGE	10 ~ 50ml/min		
FLOW PER ROTATION	0.11ml/r		
APPLICABLE TUBE	P-PHARMED TUBE S-SILICONE TUBE		
CONNECTING TUBE	INSIDE DIAMETER: ϕ 4mm		
DISCHARGE PRESSURE	0.03MPa		

MODEL	FLOW (ml/min)		
	PT-CP1 (24V)	10	30
WEIGHT (g)	190	186	182

Setting metal working plan

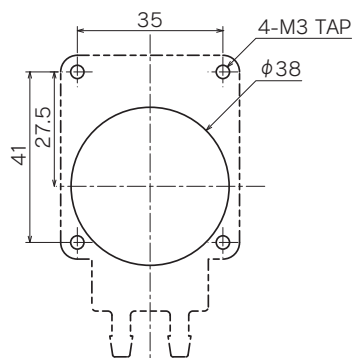

Outline drawing

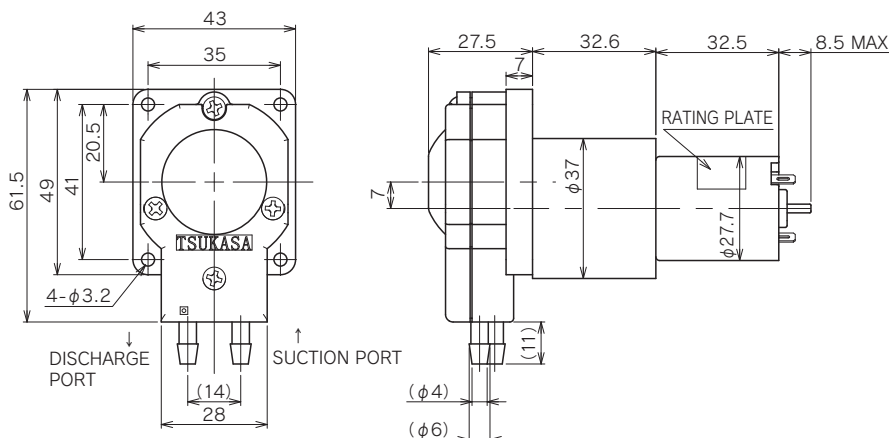

D type

APPLICATION

CLEANING EQUIPMENT / CHEMICAL LIQUID SUPPLYING EQUIPMENT etc.



Characteristics / Specification DC24V

FLOW COVER RANGE	50 ~ 200ml/min		
FLOW PER ROTATION	0.6ml/r		
APPLICABLE TUBE	P-PHARMED TUBE N-NORPRENE TUBE S-SILICONE TUBE		
CONNECTING TUBE	INSIDE DIAMETER: $\phi 4$ mm		
CLAMP TYPE APPLICABLE TUBE	INSIDE DIA. $\phi 4$ mm \times OUTSIDE DIA. $\phi 6$ mm POLYETHYLENE TUBE NYLON TUBE		
DISCHARGE PRESSURE	0.1MPa		

MODEL	FLOW (ml/min)		
PT-DP1 (24V)	50	100	200
WEIGHT (g)	236	345	345

Setting metal working plan

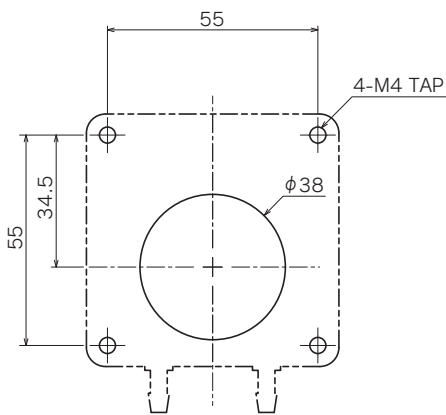

Outline drawing

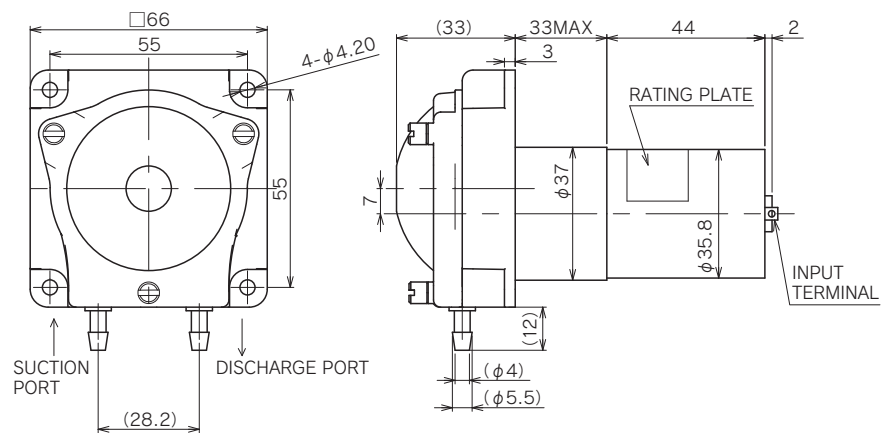

B type

APPLICATION

PRINTING PRESS / CHEMICAL LIQUID SUPPLYING EQUIPMENT etc.



Characteristics / Specification DC24V

FLOW COVER RANGE	50 ~ 450ml/min		
FLOW PER ROTATION	1.55ml/r		
APPLICABLE TUBE	P-PHARMED TUBE N-NORPRENE TUBE S-SILICONE TUBE		
CONNECTING TUBE	INSIDE DIAMETER: $\phi 5$ mm		
DISCHARGE PRESSURE	0.03MPa		

MODEL	FLOW (ml/min)		
PT-BP1 (24V)	50	150	450
WEIGHT (g)	500	500	500

Setting metal working plan

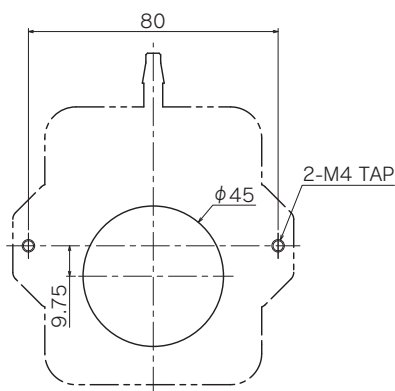

Outline drawing

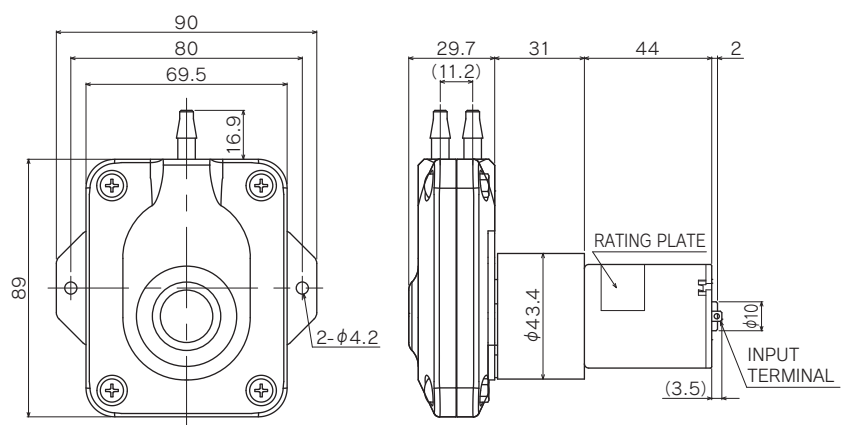

E type

APPLICATION

PRINTING PRESS / CHEMICAL LIQUID SUPPLYING EQUIPMENT etc.

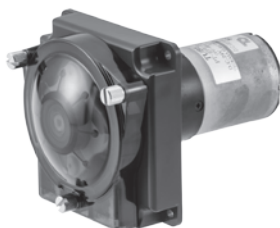

Characteristics / Specification DC24V

FLOW COVER RANGE	200 ~ 1000ml/min		
FLOW PER ROTATION	2.1 ~ 3.8ml/r		
APPLICABLE TUBE	P-PHARMED TUBE N-NORPRENE TUBE S-SILICONE TUBE		
CONNECTING TUBE	INSIDE DIAMETER: $\phi 6$ mm		
CLAMP TYPE APPLICABLE TUBE	INSIDE DIA. $\phi 6$ mm \times OUTSIDE DIA. $\phi 8$ mm POLYETHYLENE TUBE NYLON TUBE		
DISCHARGE PRESSURE	0.1MPa		

MODEL	FLOW (ml/min)		
PT-EP (24V)	350	500	1000
WEIGHT (g)	450	450	530

Setting metal working plan

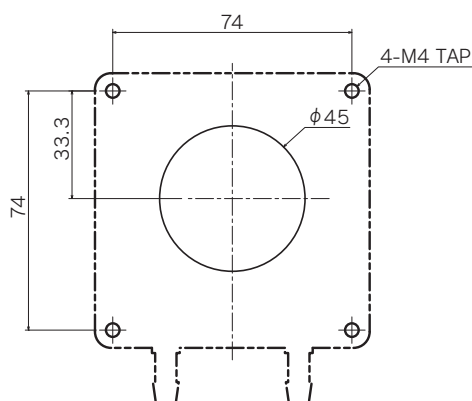

Outline drawing

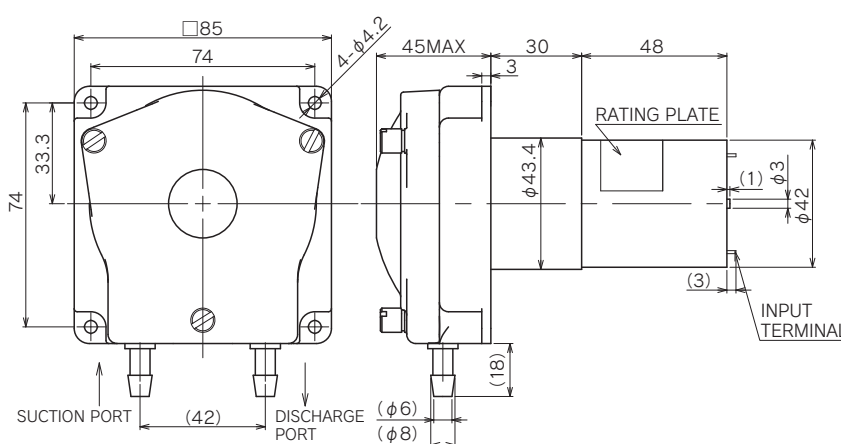

F type

APPLICATION

FILLING MACHINE / LAUNDRY / INK JET etc.



Characteristics / Specification DC24V

FLOW COVER RANGE	550 ~ 1400ml/min		
FLOW PER ROTATION	7.5ml/r		
APPLICABLE TUBE	P-PHARMED TUBE S-SILICONE TUBE		
CONNECTING TUBE	INSIDE DIAMETER: $\phi 8$ mm		
DISCHARGE PRESSURE	0.1MPa		

MODEL	FLOW (ml/min)		
PT-FP (24V)	550	1000	1400
WEIGHT (g)	780	780	780

Setting metal working plan

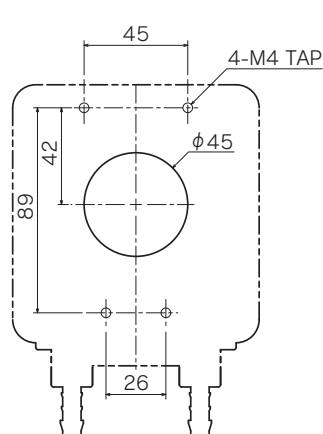

Outline drawing

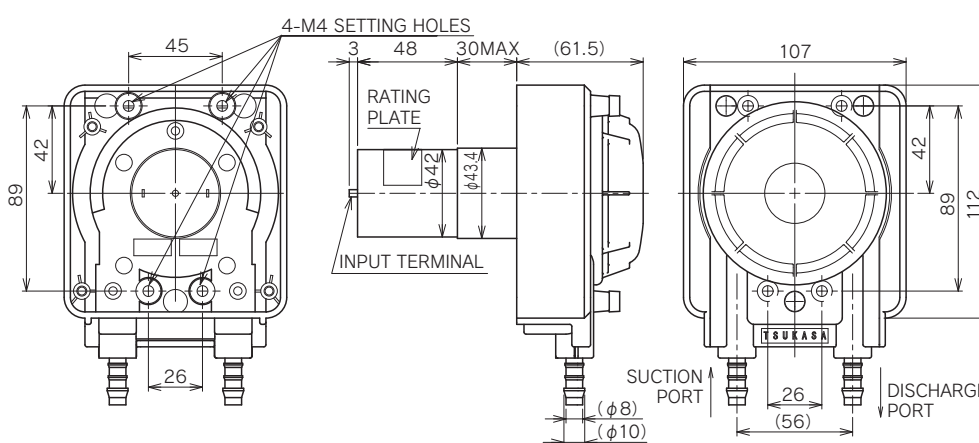

Description for part number and Model selection

P T - C P 1 - 5 0 - K A , 2 4 V

① ② ③ ④ ⑤ ⑥ ⑦

① PT = TUBE PUMP

② PUMP HEAD MODEL

(Select from H, C, D, B, E or F type.)

Refer to each page for details.

③ TUBE MATERIAL

P — PHARMED TUBE

S — SILICONE TUBE

N — NORPRENE TUBE

* For tube selection, consult us by referring to the liquid compatibility table.

④ FITTING

1. BARB TYPE

2. CLAMP TYPE

3. OTHERS

⑤ FLOW ml/min

Refer to each page for details.

⑥ CONTROL BRANCH NUMBER

—KA STANDARD TYPE

—F*** CUSTOM NUMBER

⑦ VOLTAGE = DC 24V

REPLACEMENT TUBE (TUBE PUMP ONLY)



BARB TYPE



CLAMP TYPE

MODEL EXPLANATION

EX. : **F P 1 TUBE Assy**

① ② ③

① PUMP HEAD TYPE : D, E, F

② TUBE MATERIAL : P (PHARMED TUBE)

③ FITTING : 1 (BARB TYPE)
: 2 (CLAMP TYPE) * Applicable for D and E (except 350ml/min) types only.

* B, C and H types are replaced together with the pump head.

Page useful for tube pump selection

1

Tube selection is an important item for the tube pump.

Tubes are selected based on the mechanical strength or chemical resistance. There is, however, no tube which satisfies both factors at present. For the time being, select the tube suitable for the liquid to be used.

[Tube type]

- Silicone tube: silicone rubber
 - Pharmed tube: Olefinic system thermoplastic elastomer (Norprene tube)
 - Fluran tube: Fluorine elastomer
- } For food hygiene law article

2

Selection of drive source is also an important item for the tube pump.

Selecting an optimum drive source from our various geared motors eliminates forcible load in pump operation and greatly improves the pump life.

3

The discharge capacity is the volume of liquid discharged from the outlet of the pump and expressed in the unit of ml/min or cc/min.

4

Back pressure is the pressure reversely applied from the outside to the pump discharge side and expressed in MPa or other units.

5

Head is the maximum height of liquid raised upward from the discharge port of the pump. (Discharge head)

6

Suction height is the height to suck the liquid from the lower place under the pump. This distance, if taken larger, influences the tube and discharge capacity. Install the pump by minimizing this distance and enlarging the head preferably.

7

The tube pump can handle highly viscous liquid. It is, however, necessary to take care since discharge capacity greatly lowers. In addition, overloading on the drive source (motor) is predicted, greatly influencing the life. In such a case, it is necessary to take a measure by selecting a drive source higher by one rank.

8

The tube pump has the structure of check valve operation, by pressing a certain portion of a tube with a roller. It has a function as a check valve. However, its effect is not necessarily perfect depending on discharge pressure or capacity. Please examine to separately install a check valve for such purpose.

9

A care should be taken since temperature characteristics influence discharge capacity. This is because liquid viscosity changes by temperature. Discharge capacity tends to decrease at lower temperature and increase at higher temperature.

10

The life of the pump is determined by the breakage of tube because of use frequency or the life of the drive motor.

11

Pulsating flow is the phenomenon where the liquid coming out of the discharge port stops for a certain time or discharge interval prolongs. Our tube pumps also show this tendency. (We are working through the elimination of pulsation as the theme of development.)

* Contact our sales representatives for other unclear points if any or further information.

Tube — Liquid compatibility table

Chemical correspondence table of tubes adopted on TSUKASA tube pumps

CRITERION: ◎EXCELLENT ○GOOD △NOT RECOMMENDED ×UNUSABLE

USE OF CHEMICAL LIQUID	CHEMICAL LIQUID NAME	SILICONE	PHARMED	NORPRENE	FLURAN
DISINFECTING, CLEANING, PAINT PEELING, WATER REMOVER FOR FUEL	ISOPROPYL ALCOHOL	×	△	△	◎
POISONOUS CHEMICAL SOLVENT	ETHYL ALCOHOL	△	△	△	×
SAME AS ABOVE	ETHER	×	△	△	×
ANTIFREEZING SOLUTION	ETHYLENE GLYCOL	◎	◎	◎	◎
HOME CLEANING, MEDICINE	AMMONIA WATER, 30% (w)	×	◎	◎	×
DAMP-PROOFING, SNOW MELTING AGENT, BEAN CURD SOLIDIFICATION, FOOD ADDITIVE	LIQUID CALCIUM CHLORIDE, 30% (w)	◎	◎	◎	◎
BEAN CURD BITTERN, FERTILIZER	LIQUID MAGNESIUM CHLORIDE, 35% (w)	◎	◎	◎	◎
HIGHLY POISONOUS, CHEMICAL FERTILIZER	METHYL CHLORIDE	×	△	△	×
BLEACHING, STERILIZING, FOOD ADDITIVE	HYDROGEN PEROXIDE SOLUTION, 90%	△	○	○	◎
FERTILIZER	AMMONIUM PERSULFATE SOLUTION, 30%	◎	◎	◎	◎
DETERGENT, RINSE, BEAUTY TREATMENT, SCALE REMOVING	CITRIC ACID SOLUTION, 10-20% (w)	◎	◎	◎	◎
PHOTO	DEVELOPING FLUID	○	○	○	◎
PAINT, MANICURE, FOOD ADDITIVE	ETHYL ACETATE	×	○	○	×
DYES MORDANT, FOOD PRESERVATION	SODIUM ACETATE SOLUTION, 55% (w)	◎	◎	◎	◎
ADHESIVE	VINYL ACETATE	×	○	○	×
BLEACHING AGENT	POTASSIUM HYPOCHLORITE, 70% (w)	◎	◎	◎	◎
DISINFECTING, STERILIZING, FOOD ADDITIVE	SODIUM HYPOCHLORITE, 12.2% (w)	×	◎	◎	◎
FIRE EXTINGUISHING COMPOSITIONS, COOKING, KITCHEN, BATHING, MEDICAL TREATMENT, GARDENING	SODIUM BICARBONATE, 7% (w)	◎	◎	◎	◎
MEDICAL TREATMENT, FOOD ADDITIVE	TARTARIC ACID SOLUTION, 56% (w)	◎	◎	◎	◎
GREASE, COMPOSITE OIL, ANTIFOAMING AGENT, COSMETICS, COMMODITY	SILICONE OILS	×	△	△	◎
DETERGENT, GREASE REMOVING, FOOD ADDITIVE	SODIUM HYDROXIDE, 30-40% (w)	◎	◎	◎	◎
PLASTIC, RUBBER, ADDITIVE FOR PAINT	CALCIUM CARBONATE DILUTION, 25%	◎	◎	◎	◎
BLEACHING, BEAUTY, FOOD ADDITIVE, MEDICAL TREATMENT, BUILDING MATERIAL, DIESEL EXHAUST EMISSION	UREA SOLUTION, 20% (w)	◎	◎	◎	◎
MAKE-UP, KITCHEN, DETERGENT	BLEACH SOLUTION, 22% (w)	×	◎	◎	◎
PLATING PROCESS	PLATING SOLUTION	×	◎	◎	◎
INK MATERIAL, REDUCING AGENT, MORDANT, PRESERVATIVE, MEDICINE	FERROUS SULPHATES SOLUTION, 5% (w)	◎	◎	◎	◎
FUEL, DETERGENT	KEROSENE	×	×	×	◎
FUEL	GASOLINE	×	×	×	◎
HIGHLY POISONOUS, SOLVENT, CHEMICAL FERTILIZER	BENZENE	×	×	×	×
HIGHLY POISONOUS, ADHESIVE, PRESERVATIVE, PAINT MATERIAL	FORMALDEHYDE, 37% (w)	△	×	×	×
MACHINING	CUTTING OIL FOR MACHINING	×	×	×	◎

* The list shows a part of liquid medicines. Many of liquid medicines actually used are composed of the mixture of multiple items. Damage to the tube may be enlarged further in such cases. Anyhow, verification tests will be necessary using actual liquids. Pharmed tube, Norprene tube and Fluran are brand names of Saint Gobain.

Gear pump

TG-47G-PU-DB4-KA, 24V



Characteristics / Specification

MODEL	47G-PU-DB4
VOLTAGE	24V
RATED DELIVERY PRESSURE (MPa)	0.05
RATED DELIVERY PRESSURE (kg/cm ²)	0.5
RATED DELIVERY FLOW (ml/min), MIN	400
RATED CURRENT (mA), MAX	400

(Representative value)

TG-85E-PU-DB4-KA, 24V

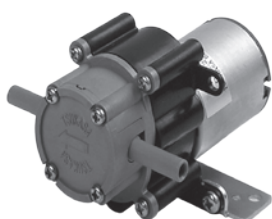

Characteristics / Specification

MODEL	85E-PU-DB4
VOLTAGE	24V
RATED DELIVERY PRESSURE (MPa)	0.05
RATED DELIVERY PRESSURE (kg/cm ²)	0.5
RATED DELIVERY FLOW (ml/min), MIN	270
RATED CURRENT (mA), MAX	350

(Representative value)

TG-85E-PU-EB4-KA, 24V

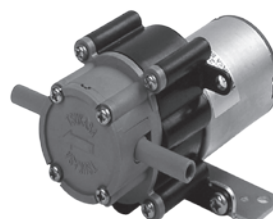

Characteristics / Specification

MODEL	85E-PU-EB4
VOLTAGE	24V
RATED DELIVERY PRESSURE (MPa)	0.1
RATED DELIVERY PRESSURE (kg/cm ²)	1
RATED DELIVERY FLOW (ml/min), MIN	500
RATED CURRENT (mA), MAX	500

(Representative value)

TG-30S-PU-DB-KA, 24V

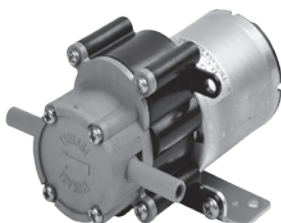

Characteristics / Specification

MODEL	30S-PU-DB
VOLTAGE	24V
RATED DELIVERY PRESSURE (MPa)	0.1
RATED DELIVERY PRESSURE (kg/cm ²)	1
RATED DELIVERY FLOW (ml/min), MIN	800
RATED CURRENT (mA), MAX	1000

(Representative value)

TG-30S-PU-EB-KA, 24V

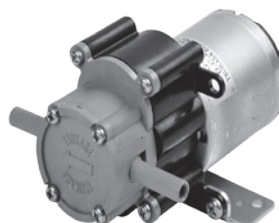

Characteristics / Specification

MODEL	30S-PU-EB
VOLTAGE	24V
RATED DELIVERY PRESSURE (MPa)	0.1
RATED DELIVERY PRESSURE (kg/cm ²)	1
RATED DELIVERY FLOW (ml/min), MIN	1300
RATED CURRENT (mA), MAX	1300

(Representative value)





GEARED MOTORS SELECTION GUIDE

SPECIFICATIONS OF MOTORS						MATCHING GEAR BOX																				
MODEL	OUTPUT	VOLTAGE	RATED TORQUE		RATED SPEED	GU	EU	RU	FU	KU (KUP)	SU	VG	VM	SS	LG	SG	SM	AGD	AMD	WM	BG	BE	BM	AP	JM	
			(mN·m)	(gf·cm)																						
TG-87A	1.7	12	1.47	15	11000	●																				
TG-87B	1.7	24	1.47	15	11000	●																				
TG-101C	2	24	1.47	15	13000	●																				
TG-01F	0.4	24	0.98	10	4250		●		●																	
TG-01G	0.8	24	0.98	10	8000		●		●																	
TG-01H	0.8	12	0.98	10	8000		●		●																	
TG-201A	1.1	24	2.45	25	4300		●		●																	
TG-201B	2	24	2.94	30	6400		●		●																	
TG-47E	0.9	24	1.96	20	4420		●		●			●	●		●	●	●	●	●	●	●	▲				
TG-47F	2	24	2.94	30	6700		●		●			●	●		●	●	●	●	●	●	●	▲				
TG-47G	3.6	24	3.92	40	8900		●		●			●	●		●	●	●	●	●	●	●	▲				
TG-47G	0.9	12	1.96	20	4450		●		●			●	●		●	●	●	●	●	●	●	▲				
TG-301A	1.2	24	1.96	20	5976									●	●	●	●	●	●			●				
TG-05D	2.2	6	3.92	40	5350					●	●			●	●	●	●	●	●			●	●	●	●	●
TG-05J	1.7	24	3.92	40	4200					●	●	●	●	●	●	●	●	●	●	●	●	●	●	●	●	●
TG-05K	2.5	24	3.92	40	6100					●	●	●	●	●	●	●	●	●	●	●	●	●	●	●	●	●
TG-05L/P	3.5	24	3.92	40	8650					●	●	●	●	●	●	●	●	●	●	●	●	●	●	●	●	●
TG-05L/P	1.2	12	2.94	30	4040					●	●	●	●	●	●	●	●	●	●	●	●	●	●	●	●	●
TG-05R	2.3	12	3.92	40	5700					●	●			●	●	●	●	●	●			●	●	●	●	●
TG-06D	4.4	12	9.8	100	4250					●	●			●	●	●	●	●	●			●	●	●	●	●
TG-06E	4.3	24	9.8	100	4200					●	●			●	●	●	●	●	●			●	●	●	●	●
TG-85B	5.5	12	11.8	120	4500					●	●			●	●	●	●	●	●			●	●	●	●	●
TG-85C	5.5	24	11.8	120	4500					●	●			●	●	●	●	●	●			●	●	●	●	●
TG-85E	8	24	11.8	120	6500					●	●			●	●	●	●	●	●			●	●	●	●	●
TG-307C	10	24	34.3	350	2810					●	●			●	●	●	●	●	●			●	●	●	●	●
TG-307D	9.3	12	34.3	350	2600					●	●			●	●	●	●	●	●			●	●	●	●	●
TG-30P/S	11	24	23.5	240	4562					●	●			●	●	●	●	●	●			●	●	●	●	●
TG-401A	11	24	25.5	260	4000					●	●			●	●	●	●	●	●			●	●	●	●	●
TG-21Q	13	24	29.4	300	4350					●	●			●	●	●	●	●	●			●	●	●	●	●
TG-21R	17	12	29.4	300	5650					●	●			●	●	●	●	●	●			●	●	●	●	●
TG-77A	26	24	98	1000	2550					●	●			●	●	●	●	●	●			●	●	●	●	●
TG-78A	46	24	147	1500	3000					●	●			●	●	●	●	●	●			●	●	●	●	●
TG-22A	2.6	24	5.88	60	4270				●																	
TG-22D	2.6	12	5.88	60	4270				●																	
TG-611B	3.5	24	5.88	60	5700				●																	
TG-55L	5.4	24	19.6	200	2650					●	●					●		●				●	●	●	●	●
TG-55L	1.4	12	19.6	200	700					●	●					●		●				●	●	●	●	●
TG-55M	8.4	24	14.7	150	5450					●	●					●		●				●	●	●	●	●
TG-55M	3.3	12	14.7	150	2150					●	●					●		●				●	●	●	●	●
TG-55N	7.5	24	9.8	100	7350					●	●					●		●				●	●	●	●	●
TG-55N	3.2	12	9.8	100	3120					●	●					●		●				●	●	●	●	●
TG-609A			78.4	800	2870																					
TG-609B	24	24	78.4	800	3270																					
TG-609C			78	800	3270																					●

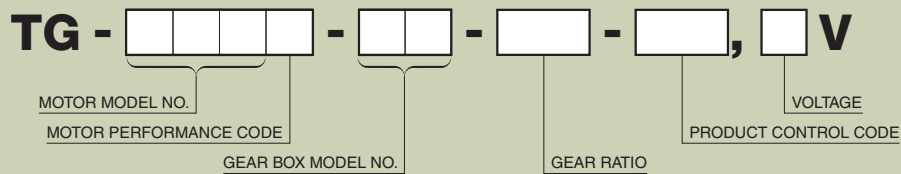
● Can be assembled. ▲ Please feel free to ask Sales Dept. Possibly available.

EXPLANATION OF MODEL NUMBER



- HA**  Standard product.
- HB**  Std., with leads (1=200mm Red, Black)
- HC**  AGD, AMD with M3 mounting holes.
- HD**  M3 mounting holes and leads.
- KA-KD** Shape is HA~HD but spur gear.
- D,E and F** Custom made product.
- V,S and Q,R** Sample or pre-production unit.

Example

TG-05K-SG-150-HA, 24V



TG-05K-SG-150-F038, 24V

