



UBS series

-The situation of simple operation and easy control

Page

- 51 System wiring diagrams
- 52 Specifications and characteristics of Motor/Driver
- 53 Gearhead specifications & allowable speed range/allowable torque/allowable inertia load (GD^2)
- 53 Motor allowable radial load/axial load
- 54 Speed - Torque characteristic diagrams
- 55 Driver panel functions and wiring instructions
- 56 Motor electromagnetic brake wiring instructions
- 57 Dimensions - Motor/Gearhead
- 59 Dimensions - Driver
- 59 Dimensions - Power supply noise filter

DC brushless Motor- UBS series

System wiring diagrams

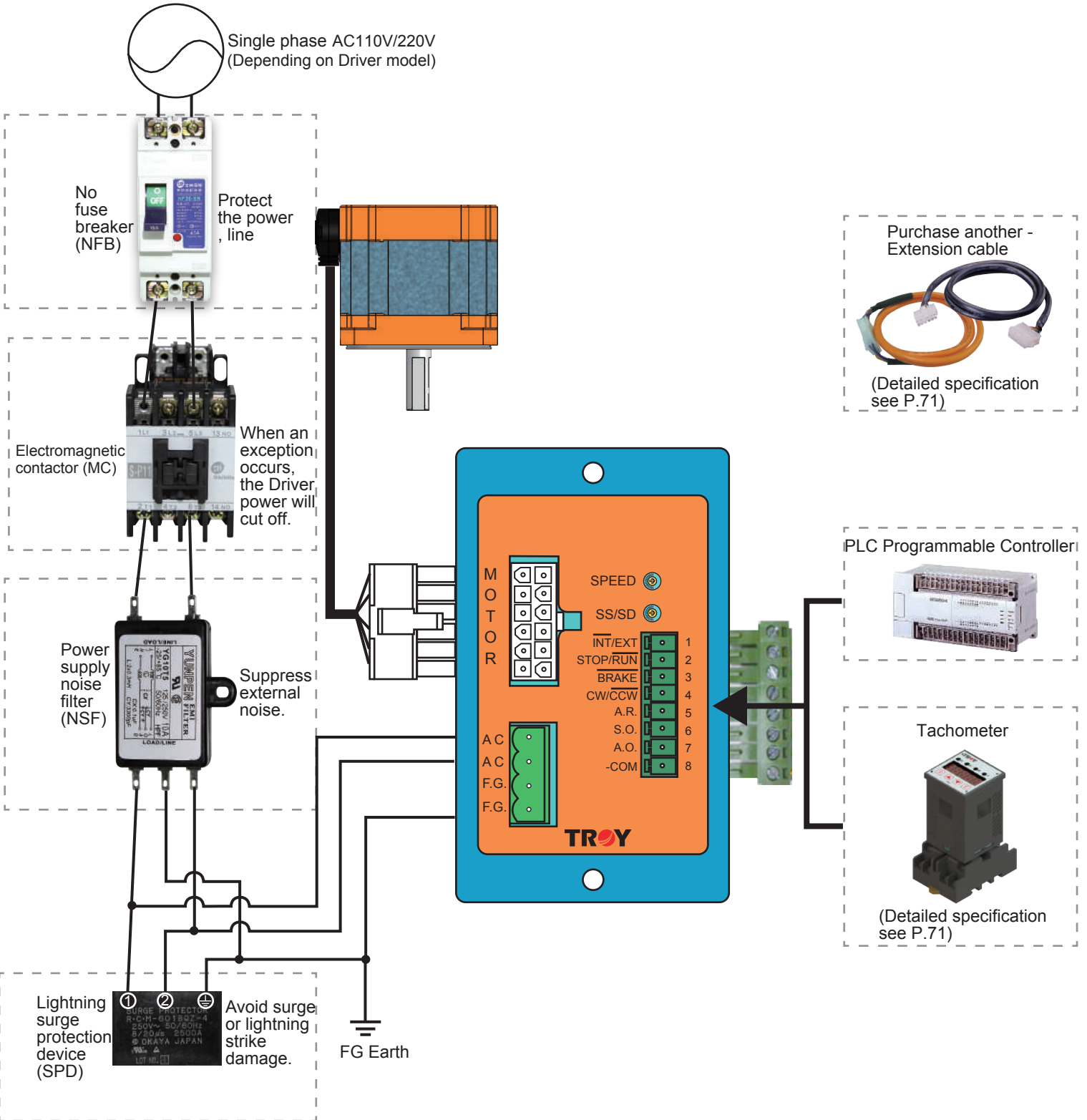

- Power supply noise filter (NSF):
Our company's products comes with 10A power supply noise filter.
- Lightning surge protection device (SPD) wiring precautions:
Different brands have different wiring , refer to each original proposal to do the wiring diagram wiring.



■ Specifications and characteristics of Motor/Driver

Motor output power		20W	40W	60W	90W	
Round shaft Motor (M: E/M brake type)		6B020S-□N(M) (Note 1)	6B040S-□N(M)	9B060S-□N(M)	9B090S-□N(M)	
Pinion shaft Motor (M: E/M brake type)		6B020P-□N(M)	6B040P-□N(M)	9B060PD-□N(M)	9B090PD-□N(M)	
Motor specification certificates	-1 Type					
	-2 Type			(Note 2)		
Driver		UBD020-□N	UBD040-□N	UBD060-□N	UBD090-□N	
Driver specification certificates						
Input power voltage	-1 Type Single Phase AC110~115V 50/60 HZ	Max. Current (A)	2.4	2.4	2.5	2.9
		Rated Current (A)	0.59	0.99	1.48	1.93
	-2 Type Single Phase AC220~230V 50/60 HZ	Max. Current (A)	1.7	1.7	1.7	1.7
		Rated Current (A)	0.33	0.56	0.82	1.05
Starting Torque (Nm)		0.15	0.25	0.45	0.65	
Rated Torque (Nm)		0.10	0.20	0.30	0.50	
Allowable load inertia GD ² (Kgcm ²)		14.01	23.23	39.42	54.23	
E/M Brake ※ Only E/M brake series have E/M	Input line voltage(V)		DC24		DC24	
	Consumption power(W)		6.5		7.5	
	Maintenance(Nm)		0.3		0.5	
	Attraction time(ms)		30		33	
	Release time(ms)		87		95	
Speed control range(r/min)		250~2000				
Speed variation rate	To load	-1%Max.	at 2000r/min, no load~rated load.			
	To voltage	±2%	Voltage variation ±15%, at 2000r/min, no load.			
	To Temperature	±2%	0~+40°C at 2000r/min, no load.			
Slow start/Slow down time set up		Slow start 0.5~8sec, Motor from 0~2000r/min when no load Slow stop 0.5~7sec, Motor from 2000~0r/min when no load				
Speed control method		<ul style="list-style-type: none"> Controlled by front panel knob for speed Controlled by back panel knob for speed 				
Signal input/output methods		<ul style="list-style-type: none"> Photo coupler input interface Transistor Open Collector output interface 				
Function		<ul style="list-style-type: none"> Directly switch to control the Motor start /stop from the front panel "RUN / STOP" Motor constant torque output (FLAT TORQUE) within the speed control range Instantaneous brake to stop, slow start / slow stop (SLOW START / SLOW DOWN) When brake to stop all electric type holding role 				
Protection function		When protective function is activated, Motor will coast to a stop drive ALARM contact signal output <ul style="list-style-type: none"> Overload Protection : When exceeding the rated torque of Motor running at least 7 seconds, it starts operation Overheat Protection : When Driver is internal heat sink temperature exceeds 80 ° C, starts operation Overvoltage Protection : (1)Up and down, winding or exceeds the allowable load inertia during operation, starts operation (2)When Driver voltage of the AC power input more than about 35%, starts operation Lowvoltage Protection : Driver input AC power voltage is lower than about 20%, starts operation Offline Protection : When Motor cable disconnect, starts operation 				
Insulation impedance		Applies DC500V high resistance meter test, power, F.G grounding, I/O terminal resistance value is over 100MΩ				
Insulation high voltage		Power and F.G connect to ground, terminals pass with 1.8KV/60Hz high voltage, power and I/O connectors pass with 3KV/60Hz high voltage for 1 minute, no abnormal condition				
Ambient temperature/Humidity range		0~+40°C, under 85% relative humidity (avoid dust and erosion, combustion gas)				

Note1 : -□, Please fill power voltage in □. □ indicates single phase AC110~115V · □: indicates single phase AC220~230V * 1 Nm=10.19716 Kgcm
 Note2 : 9B060PD-2N、9B090PD-2N have passed IP54 certificate.

■ Gearhead specifications & allowable speed range/allowable torque/allowable inertia load (GD²)

Gear ratio		3	3.6	5	6	7.5	9	10	12.5	15	18	20	25	30
Speed range (r/min)	High speed	666	555	400	333	266	222	200	160	133	111	100	80	66
	Low speed	83.4	69.5	50	41.7	33.4	27.8	25	20	16.7	13.9	12.5	10	8.4
Allowable torque (Nm)	6B020P-□N(M) + 6D□	0.27	0.32	0.45	0.54	0.68	0.81	0.9	1.1	1.4	1.6	1.8	2.2	2.6
Allowable inertia load GD ² (kgcm ²)		6.30	9.08	17.5	25.2	39.4	56.7	70.1	109	158	227	280	438	625
Allowable torque (Nm)	6B040P-□N(M) + 6D□	0.54	0.65	0.9	1.1	1.4	1.6	1.8	2.3	2.7	3.2	3.6	4.3	5.2
Allowable inertia load GD ² (kgcm ²)		10.5	15.1	29.0	41.8	65.3	94.1	116	181	261	376	465	625	
Allowable torque (Nm)	9B060PD-□N(M) + 9D□	0.81	0.97	1.4	1.6	2	2.4	2.7	3.4	4.1	4.9	5.4	6.5	7.7
Allowable inertia load GD ² (kgcm ²)		63.1	90.8	175	252	394	568	701	1095	1577	2271	2803	4380	6307
Allowable torque (Nm)	9B090PD-□N(M) + 9D□	1.4	1.6	2.3	2.7	3.4	4.1	4.5	5.6	6.8	8.1	9	10.8	12.9
Allowable inertia load GD ² (kgcm ²)		86.8	125	241	347	542	781	964	1506	2169	3124	3856	6026	8677

Gear ratio		36	50	60	75	90	100	120	150	180	200	250	300	360	
Speed range (r/min)	High speed	55	40	33	26	22	20	16	13	11	10	8	6	5	
	Low speed	7	5	4.2	3.4	2.8	2.5	2.1	1.7	1.4	1.3	1	0.9	0.7	
Allowable torque (Nm)	6B020P-□N(M) + 6D□	3.1	4.3	5.2	6.5				6.5						
Allowable inertia load GD ² (kgcm ²)		625						625							
Allowable torque (Nm)	6B040P-□N(M) + 6D□	6.2	6.5				6.5								
Allowable inertia load GD ² (kgcm ²)		625						625							
Allowable torque (Nm)	9B060PD-□N(M) + 9D□	9.3	12.9	15.5	19.4	23.2	25.8	29.2	36.5	40					
Allowable inertia load GD ² (kgcm ²)		9082	11000				11000								
Allowable torque (Nm)	9B090PD-□N(M) + 9D□	15.5	21.5	25.8	32.3	38.7	40	40							
Allowable inertia load GD ² (kgcm ²)		11000						11000							

* Motor 6B020P-□(M)...etc, please fill in □ with line power voltage. ① : stand for single phase AC110~115V, ② : stand for single phase AC220~230V.

* Gearhead 6D□/9D□/9D□H, please fill gear ratio in □.

In above table stands for after installation of Gearhead, the axis rotation direction is reversed with Motor axis direction; without marking stands for the same direction as Motor axis rotation.

* 1Nm = 10.197Kgcm.

* The Gearheads of all series have  certificate.

* Also available orthogonal Gearhead: hollow shaft type 9VD□(H), the solid single shaft type 9VD□A(H), the solid biaxial shaft type 9VD□B(H), and size please refer to P.10.

■ Motor allowable radial load/axial load

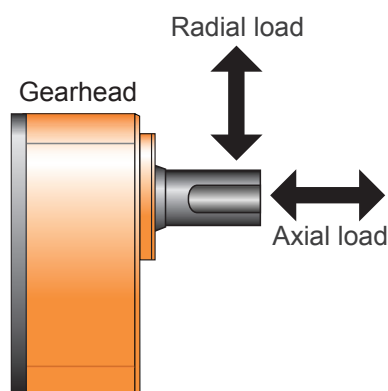

- ① Radial load (hanging load): loading is vertical to Gearhead axis power output
- ② Axial load (thrust load): loading is in the direction of Gearhead axis power output

◆ Round shaft type

Model	Permissible overhung load (Unit: Kg f)		Permissible thrust load (Unit: Kg f)
	10mm from output shaft front	20mm from output shaft front	
6B020S-□N(M)	8	9	Permissible axial loading, not more than 1/2 of motor weight. But please try to avoid applying force in the horizontal direction (axial) of motor shaft, when exceeds that will reduce motor service life. If axial loading is needed, we recommend applying indirect transmission, such as: couplings, belts, chains, etc...
6B040S-□N(M)	8	9	
9B060S-□N(M)	13	15	
9B090S-□N(M)	16	17	

◆ Pinion shaft type (Gearhead attached)

Model	Gear ratio	Permissible overhung load (Unit: Kg f)		Permissible thrust load (Unit: Kg f)
		10mm from output shaft front	20mm from output shaft front	
6B020P-□N(M) + 6D□	3, 3.6, 5	10	15	4
	6, 7.5, 9, 10, 12.5, 15, 18, 20	15	20	
6B040P-□N(M) + 6D□	25, 30, 36, 50, 60, 75, 90, 100, 120, 150, 180, 200, 250, 300, 360	20	30	15
	3, 3.6, 5	30	40	
9B060PD-□N(M) + 9D□	6, 7.5, 9, 10, 12.5, 15, 18, 20	40	50	15
	25, 30, 36, 50, 60, 75, 90, 100, 120, 150, 180, 200, 250, 300, 360	50	65	

* Motor 6B020S-□N(M)... etc., please fill power voltage in □. □ : indicate single phase AC110V~115V, □ : indicate single phase AC220~230V

* Gearhead 6D□/9D□, please fill Gearhead in □.

■ Speed - Torque characteristic diagrams

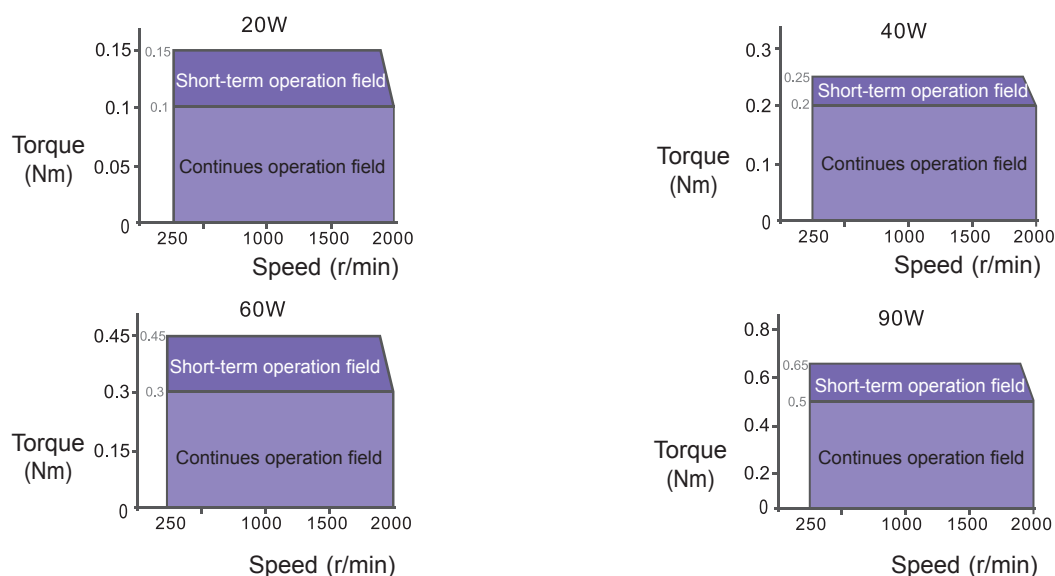

■ Driver panel functions and wiring instructions

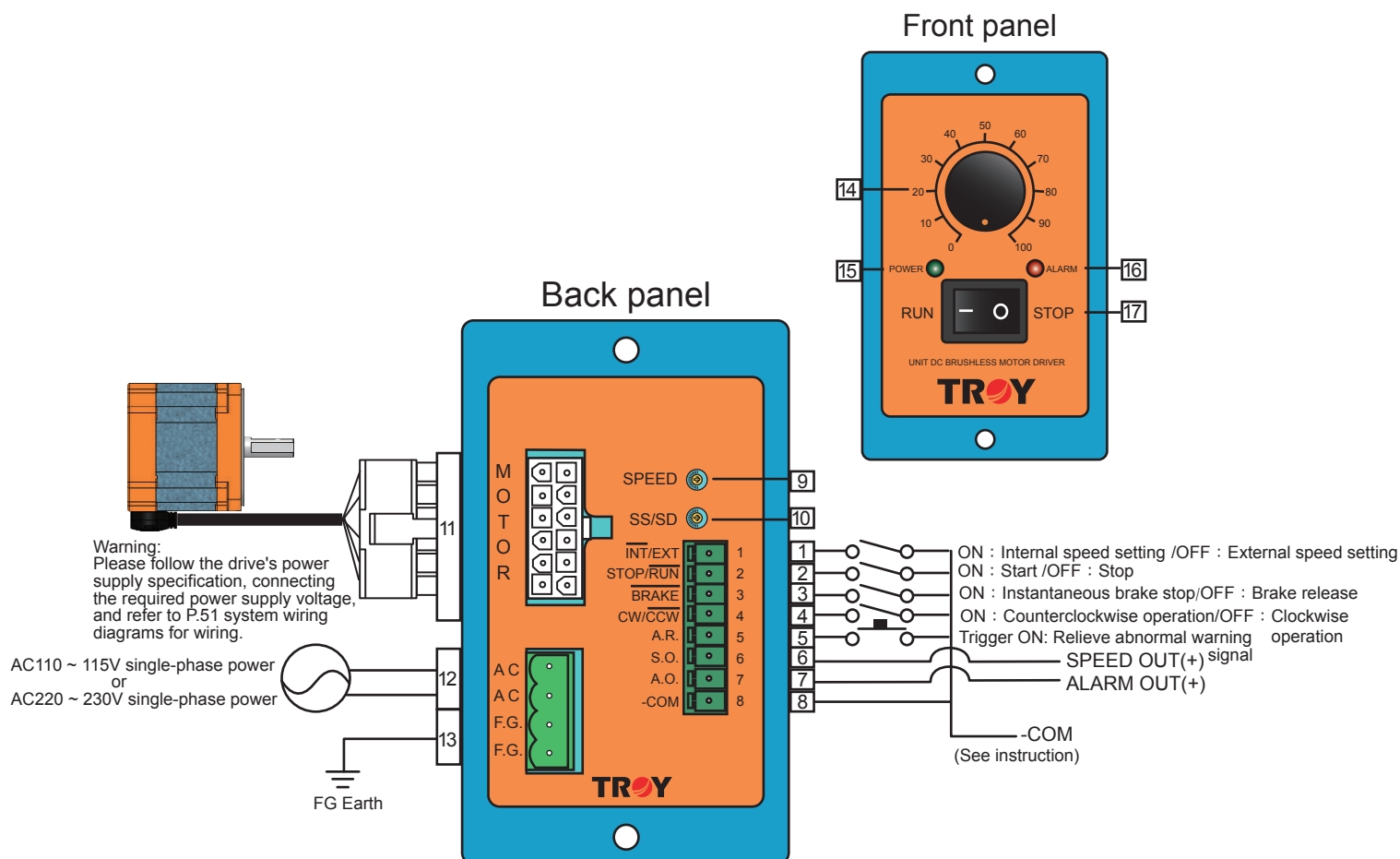

Number	Panel marked	Function	Explanation
1	INT/EXT	Speed setting mode switch to select the input	Internal / external speed setting mode switching selection
2	STOP/RUN	Stop/Start signal input	Stop / start signal switching input
3	BRAKE	Instantaneous brake stop signal input	Executive instantaneous brake stop / brake release signal switch input
4	CW/CCW	The direction of rotation switch to select the input	Clockwise/counterclockwise operation switch selection
5	A.R.	Warning signs release abnormal input	AR trigger input contacts (continuous "L" state 10ms) to release the error warning signal
6	S.O.	Speed signal output	When Motor speed is detected using, digital signal output 12 Pulse / rev
7	A.O.	Abnormal warning signal output	Overload, overheating, over voltage, low voltage, disconnection of any of a protective function is activated, Motor stops naturally, and outputs an abnormality warning signal
8	-COM	Controlling signal grounding	GND contact inputs and outputs a control signal common ground wire, and the external DC power
9	SPEED	Speed setting button	20~90W speed control range : 250~2000r/min
10	SS/SD	Slow start, stop time setting button	Slow start 0.5~8sec; slow stop 0.5~7sec
11	MOTOR	Motor wiring connector	Motor and Driver connection
12	AC	Power voltage input terminal	AC power voltage input connection
13	FG	Power ground terminal	Power ground connection
14	Scale button	Speed setting button	Rotating the knob clockwise to adjust the Motor speed from slow to fast speed range: 250 ~ 2000r/ min
15	POWER	Power indicator	Input Power LED (green) lights
16	ALARM	Unusual indicator	Overload, overheating, over-voltage, low voltage, disconnection of any of a protective function is activated LED (red) lights
17	RUN/STOP	Start / stop switch	Start / stop switch

■ Motor electromagnetic brake wiring instructions

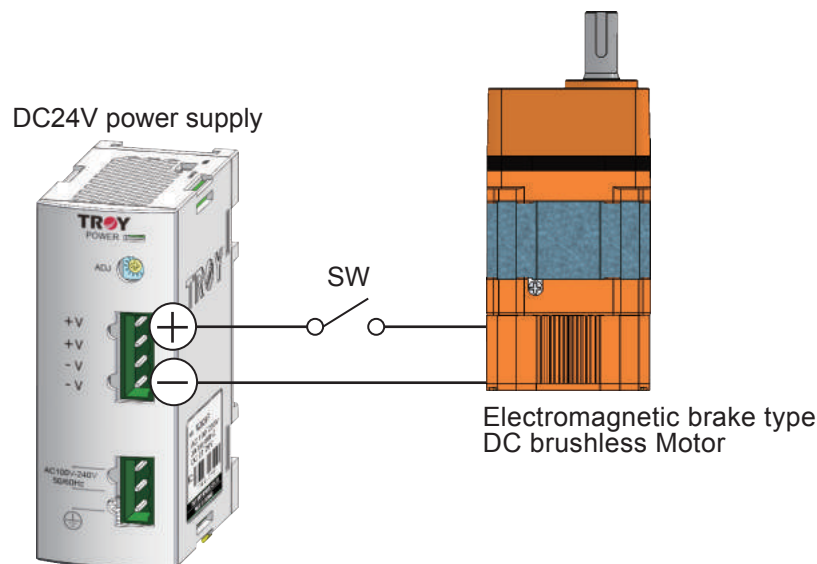

◆ Operation instruction

Motor start/Motor stop with external electromagnetic brake operating procedures:
 Motor start: Must energize external electromagnetic brake before the Motor starts

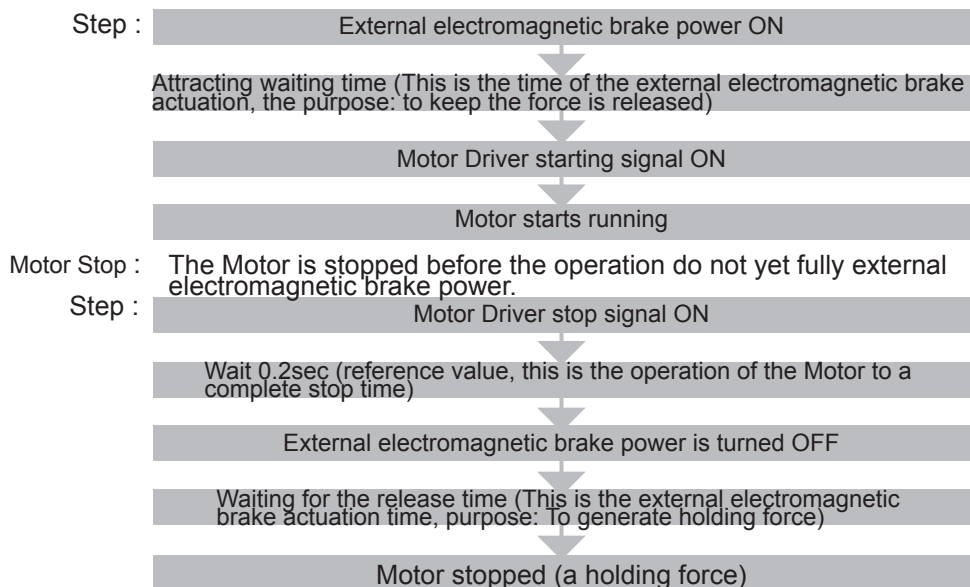

◆ Precautions

- 1.This series of external electromagnetic brake using the brake power is part of the hold-type.
- 2.External electromagnetic brake is designed to allow the Motor stops when the holding force has to be used as a safety brake, electromagnetic brake, do not use this as a Motor positioning or emergency brake applications.
- 3.Always to pull the Motor before starting the external electromagnetic brake energized (means no brakes); Motor stopped before the operation do not yet fully external electromagnetic brake power (expressed brakes).
- 4.External electromagnetic brake suction time and release time value refer to the product specification.
- 5.Motor brakes to stop for about 0.2sec (test conditions in the Motor no-load speed 3000r / min, the electromagnetic brake is energized, the brake actuator signal ON time of the Driver, this time as a reference base, but the actual length of time will stop according to the inertia load or frictional load ... different load patterns and has fluctuated.
- 6.We recommend to do the actual measuring device operating time at the time of commissioning.

■ Dimensions - Motor/Gearhead

Unit : mm

Round shaft type

Gear shaft type

20W/□60mm

◆ 6B020S-□N

Weight : 655g

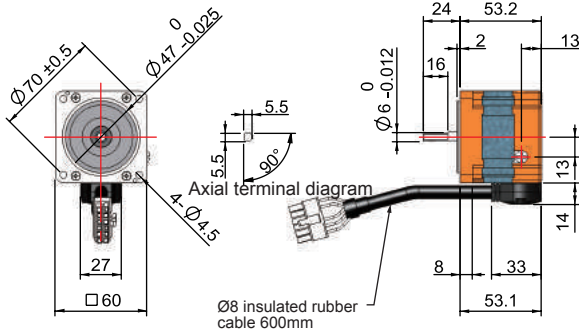

◆ 6B020P-□N + 6D□

Weight : 650g+W

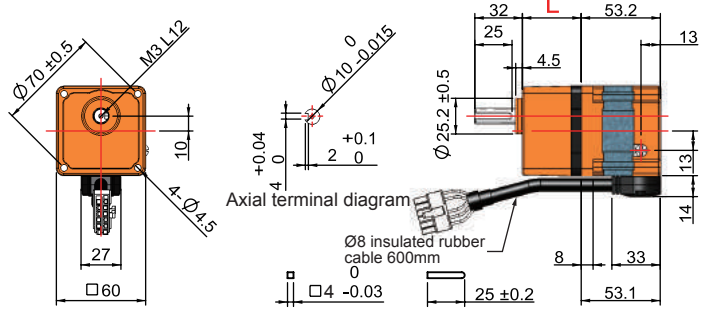

◆ 6B020S-□NM

Weight : 1055g

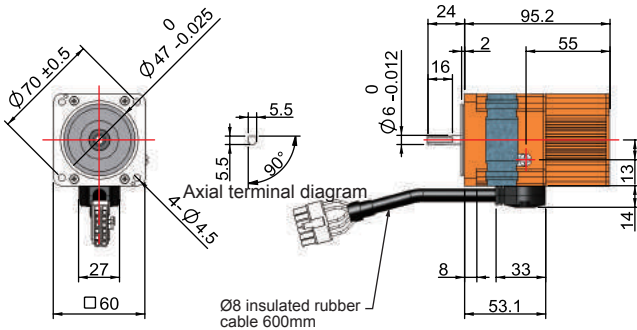

◆ 6B020P-□NM + 6D□

Weight : 1050g+W

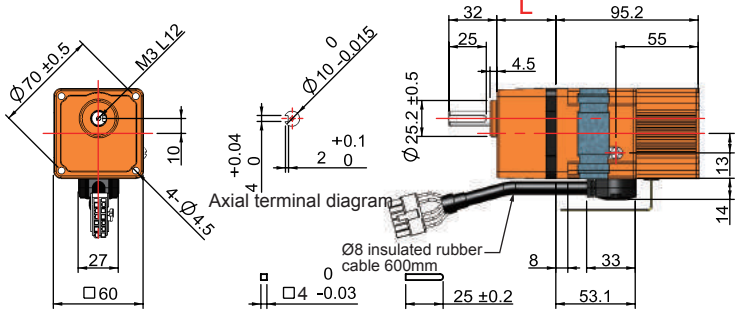

40W/□60mm

◆ 6B040S-□N

Weight : 1050g

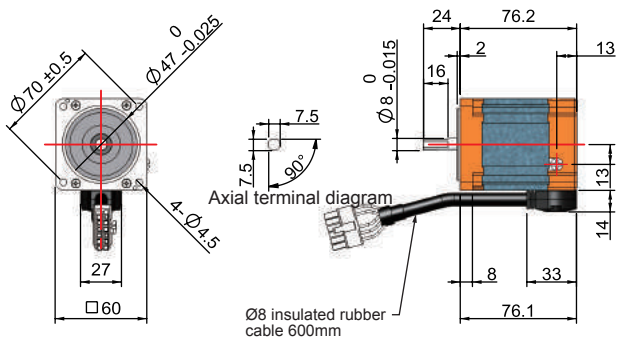

◆ 6B040P-□N + 6D□

Weight : 1040g+W

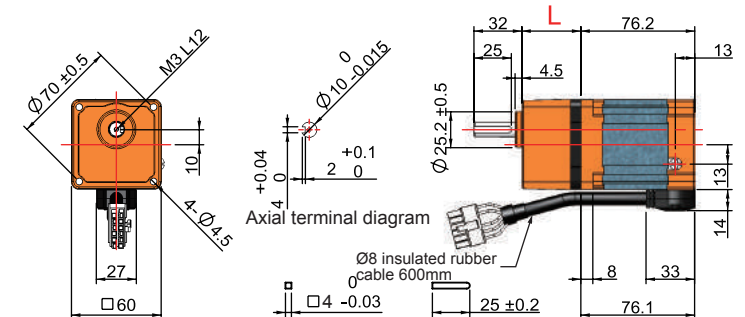

◆ 6B040S-□NM

Weight : 1450g

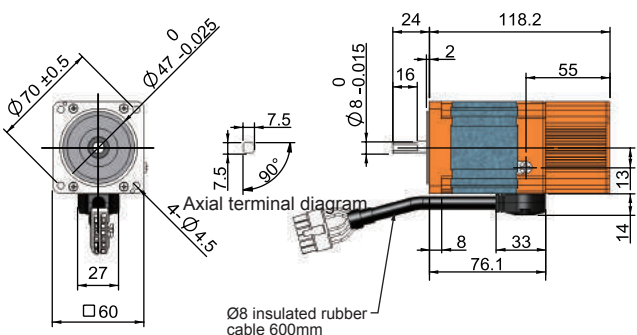

◆ 6B040P-□NM + 6D□

Weight : 1440g+W

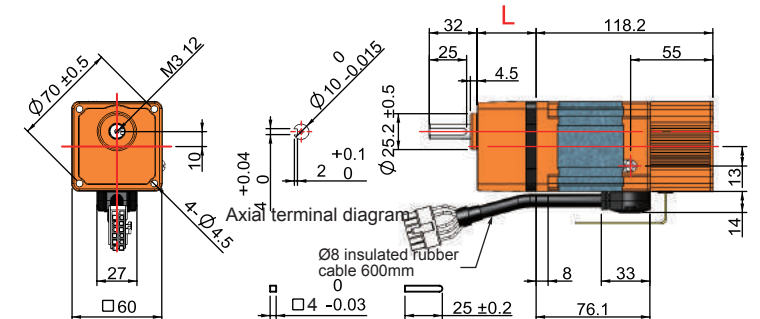

* 6B pinion shaft type 6D3-6D360, Gearhead length L and weight W specification as following:

Model	6D3~6D20	6D25~6D100	6D120~6D360
Gearhead Length L (mm)	39.5	39.5	43.5
Weight W (g)	300	325	365

* Figure above dimensions tolerance values are not labeled a general machining tolerances, the control mode, refer to P.12, others have marked tolerance values according to the drawing labeled based.

Dimensions - Motor/Gearhead

Unit : mm

Round shaft type

Gear shaft type

60W/□90mm

◆ 9B060S-□N

Weight : 1465g

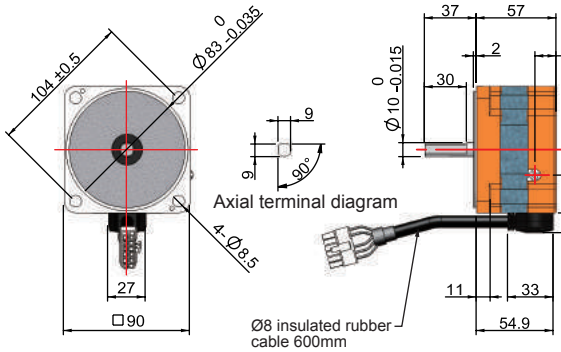

◆ 9B060PD-□N + 9D□

Weight : 1440g+W

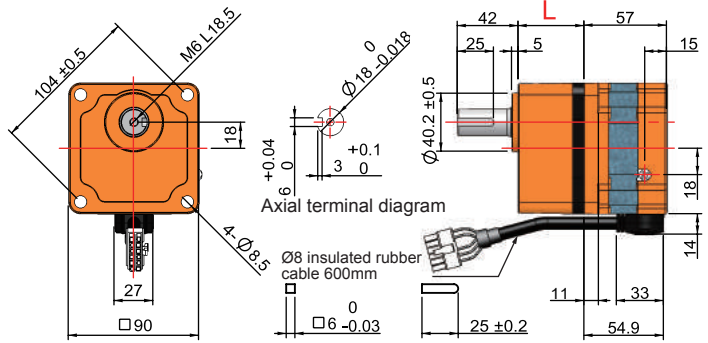

◆ 9B060S-□NM

Weight : 2215g

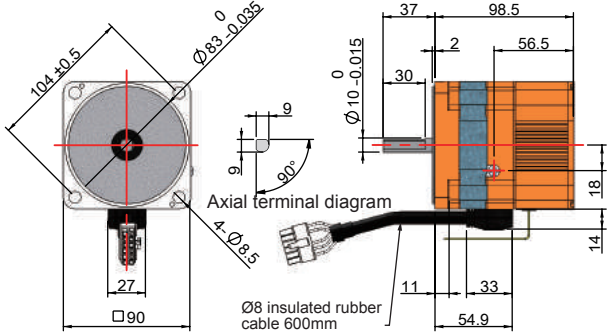

◆ 9B060PD-□NM + 9D□

Weight : 2190g+W

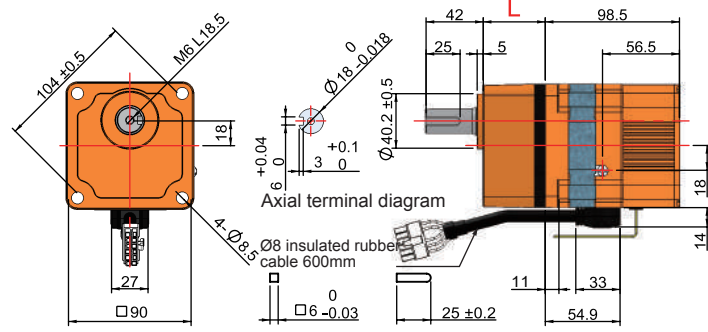

90W/□90mm

◆ 9B090S-□N

Weight : 2380g

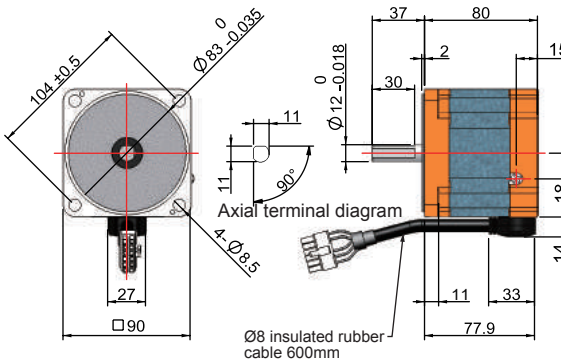

◆ 9B090PD-□N + 9D□

Weight : 2350g+W

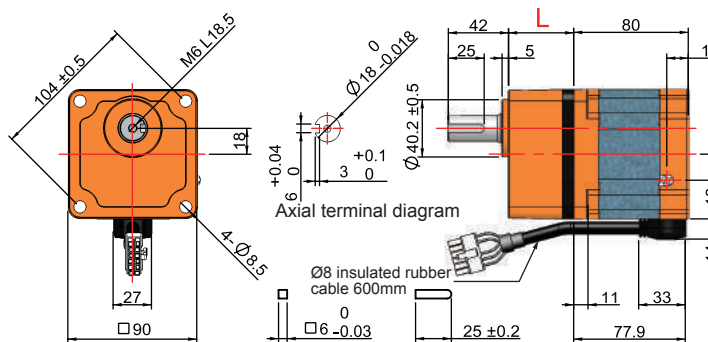

◆ 9B090S-□NM

Weight : 3130g

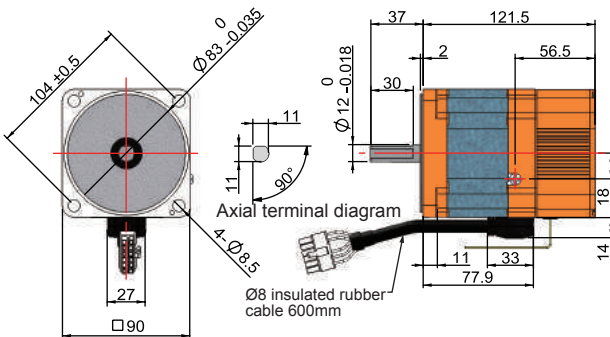

◆ 9B090PD-□NM + 9D□

Weight : 3100g+W

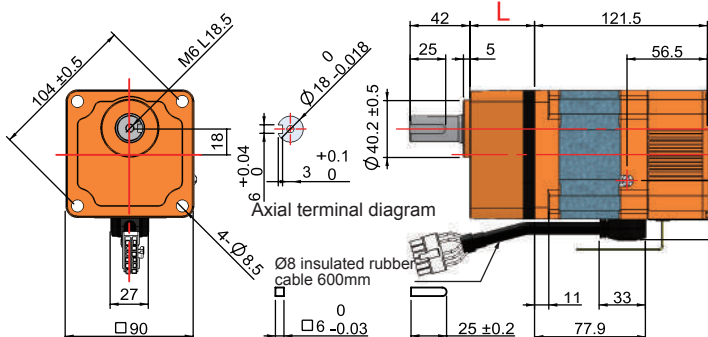

* 9B pinion shaft type 9D3-9D360, Gearhead length L and weight W specification as following:

Model	9D3~9D20	9D25~9D100	9D120~9D360
Gearhead Length L (mm)	45.5	58.5	64.5
Weight W (g)	860	1125	1265

* Figure above dimensions tolerance values are not labeled a general machining tolerances, the control mode, refer to P.12, others have marked tolerance values according to the drawing labeled based.

TRV - Characteristics of Motor Product index Product names Product weight Technical Information Gearhead Installation Certificates Model naming BMS BSS SSS CDS DSS Accessories Motor selection

■ Dimensions - Driver

Model : UBD020-□N/UBD040-□N UBD060-□N/UBD090-□N Dimensions are common Unit : mm

Weight : 520g

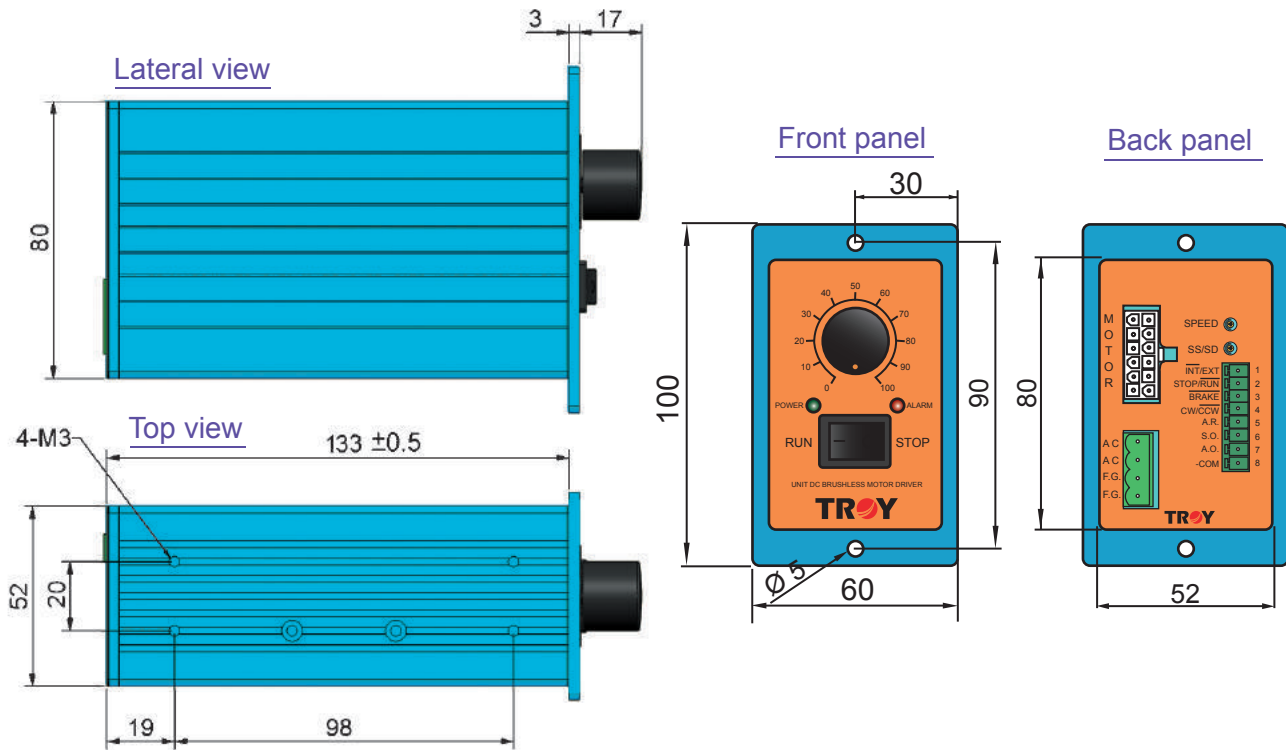

■ Dimensions - Power supply noise filter

Weight : 50g

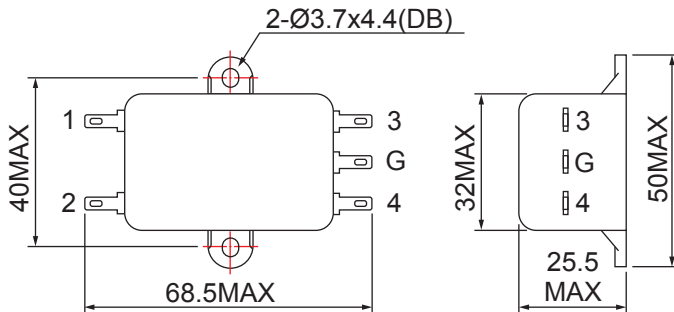

* Figure above dimensions tolerance values are not labeled a general machining tolerances, the control mode, refer to P.12, others have marked tolerance values according to the drawing labeled based.

Motor selection sheet

■ Mechanism: [Operating of large index table]

Date dd / mm / yy

Company name: _____ Contact person: _____ Department/Title: _____

TEL: _____ FAX: _____ Application: _____ Use area: _____

Power input: Single -phase AC: ___ V Three -phase AC: ___ V DC: ___ V Frequency: Hz

Activated mode: Single direction operating continuously → Rated speed
 Regulated speed (Range: ___ rpm ~ ___ rpm)
 Single direction run 、 stop 、 run 、 stop → (Activated time: ___ Second/Sequence, stop time: ___ Second/Sequence; Run, stop total ___ Sequence /Minutes)
 Clockwise/counter clockwise repeated → (CW: ___ Second/Sequence 、 Stop: ___ Second/Sequence 、 CCW: ___ Second/Sequence 、 Stop: ___ Sequence/Minute)

Required motor: AC induction motor: Induction Reversible Speed control Magnetic brake Torque
 DC brushless motor: BMS Series BS Series SBS Series UBS Series DBS Series
 Stepping motor: 2 phase 3 phase 5 phase

【Mechanism reference】

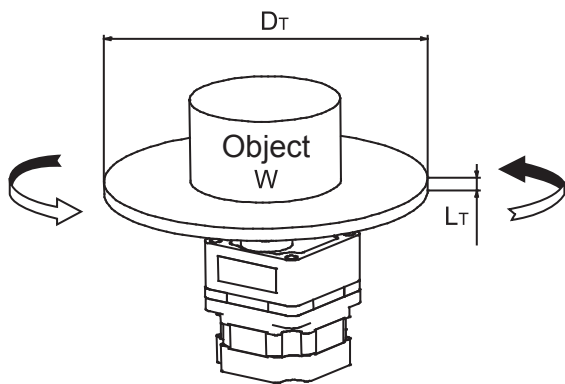

【Please sketch your actual transmission part of mechanism】

【Drive mechanism and operating data】

Object mass	W = _____ kg
Index table diameter	D _T = _____ cm
Width	L _T = _____ cm
Material	ρ = _____
Positioning angle *(note)	θ = _____ deg
Positioning time *(note)	T ₀ = _____ sec
Stopping accuracy	± _____ mm

*(note)Please enter the max speed

Recommendation products (Selected specs) :

After complete above information, please fax it to nearby regional business office, we will select applicable product for you as soon as possible

Motor selection sheet

■ Mechanism: 【Lead screw】

Date dd / mm / yy

Company name: _____ Contact person: _____ Department/Title: _____

TEL: _____ FAX: _____ Application: _____ Use area: _____

Power input: Single -phase AC: ___V Three -phase AC: ___V DC: ___V Frequency: Hz

Activated mode: Single direction operating continuously → Rated speed
 Regulated speed (Range: ___ rpm ~ ___ rpm)
 Single direction run、stop、run、stop → (Activated time: ___ Second/Sequence, stop time: ___ Second/Sequence; Run, stop total ___ Sequence /Minutes)
 Clockwise/counter clockwise repeated → (CW: ___ Second/Sequence、Stop: ___ Second/Sequence、CCW: ___ Second/Sequence、Stop: ___ Sequence/Minute)

Required motor: AC induction motor: Induction Reversible Speed control Magnetic brake
 Torque
 DC brushless motor: BMS Series BS Series SBS Series UBS Series
 DBS Series
 Stepping motor: 2 phase 3 phase 5 phase

【Mechanism reference】

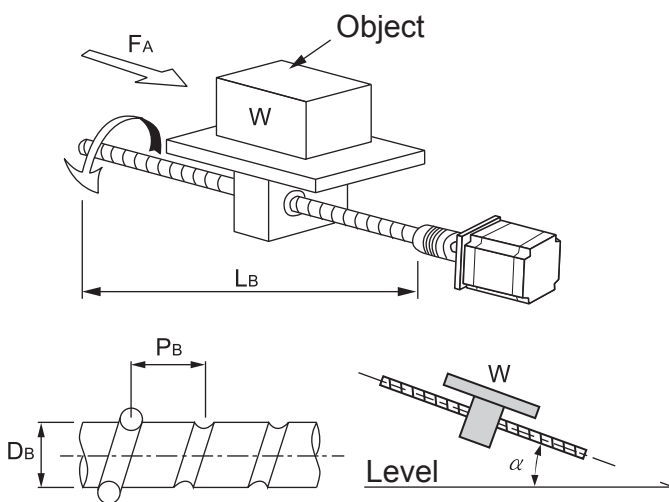

【Please sketch your actual transmission part of mechanism】

【Drive mechanism and operating data】

Work+Table mass	W = _____ kg	frictional coefficient of sliding surfaces	$\mu =$ _____
Screw angle	$\alpha =$ _____ deg	Positioning distance	L = _____ cm
Screw shaft diameter	$D_B =$ _____ cm	Positioning time	$T_O =$ _____ sec
Screw Length	$L_B =$ _____ cm	Push / Pull force	$F_A =$ _____ kg
Screw pitch	$P_B =$ _____ cm	Stopping accuracy	\pm _____ mm
Material	$\rho =$ _____		
Screw efficiency	$\eta =$ _____		
Internal frictional coefficient of pilot pressure nut	$\mu_0 =$ _____		

*(note)Please enter the max speed

Recommendation products (Selected specs) :

* After complete above information, please fax it to nearby regional business office, we will select applicable product for you as soon as possible

This page can be copied

Motor selection sheet

■ Mechanism: **[Belt and pulley]**

Date dd / mm / yy

Company name: _____ Contact person: _____ Department/Title: _____

TEL: _____ FAX: _____ Application: _____ Use area: _____

Power input: Single -phase AC: V Three -phase AC: V DC: V Frequency: Hz

Activated mode: Single direction operating continuously → Rated speed
 Regulated speed (Range: rpm ~ rpm)
 Single direction run、stop、run、stop → (Activated time: Second/Sequence, stop time: Second/Sequence; Run, stop total Sequence /Minutes)
 Clockwise/counter clockwise repeated → (CW: Second/Sequence、Stop: Second/Sequence、CCW: Second/Sequence、Stop: Sequence/Minute)

Required motor: AC induction motor: Induction Reversible Speed control Magnetic brake Torque
 DC brushless motor: BMS Series BS Series SBS Series UBS Series DBS Series
 Stepping motor: 2 phase 3 phase 5 phase

【 Mechanism reference 】

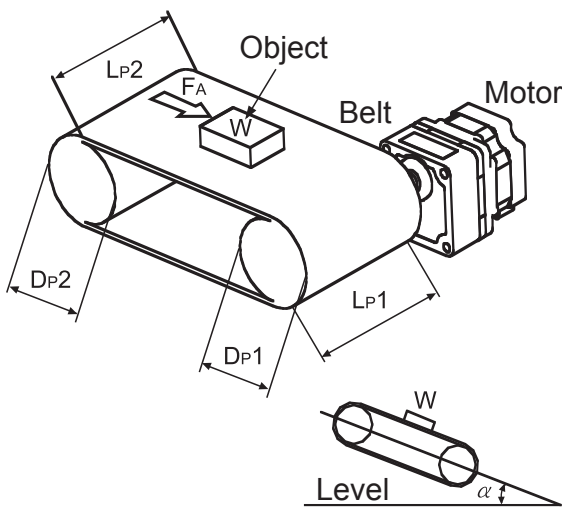

【 Please sketch your actual transmission part of mechanism 】

【 Drive mechanism and operating data 】

Work + Table + Pulley	$W = \text{_____ kg}$	Belt、pulley efficiency	$\eta = \text{_____}$
Screw angle	$\alpha = \text{_____ deg}$	frictional coefficient of sliding surfaces	$\mu = \text{_____}$
Pulley diameter	$D_{P1} = \text{_____ cm}$	Positioning distance *(note)	$L = \text{_____ cm}$
Width	$L_{P1} = \text{_____ cm}$	Positioning time *(note)	$T_O = \text{_____ sec}$
Material	$\rho 1 = \text{_____}$	Push / Pull force	$F_A = \text{_____ kg}$
Pulley diameter	$D_{P2} = \text{_____ cm}$	Stopping accuracy	$\pm \text{_____ mm}$
Width	$L_{P2} = \text{_____ cm}$		
Material	$\rho 2 = \text{_____}$	*(note)Please enter the max speed	

Recommendation products (Selected specs) :

※ After complete above information, please fax it to nearby regional business office, we will select applicable product for you as soon as possible

This page can be copied

TRV-
 Characteristics of Motor
 Product index
 Product names
 Product weight
 Technical Information
 Gearhead
 Installation
 Certificates
 Model naming
 BMS
 BS
 SBS
 CBS
 DBS
 Accessories
 Motor selection

Motor selection sheet

■ Mechanism: [Others]

Date dd / mm / yy

Company name: _____ Contact person: _____ Department/Title: _____

FAX: _____ Application: _____ Use area: _____

Power input: Single -phase AC: ___V Three -phase AC: ___V DC: ___V Frequency: Hz

Activated mode: Single direction operating continuously → Rated speed
 Regulated speed (Range: ___ rpm ~ ___ rpm)
 Single direction run、stop、run、stop → (Activated time: ___ Second/Sequence, stop time: ___ Second/Sequence; Run, stop total ___ Sequence /Minutes)
 Clockwise/counter clockwise repeated → (CW: ___ Second/Sequence、Stop: ___ Second/Sequence、CCW: ___ Second/Sequence、Stop: ___ Sequence/Minute)

Required motor: AC induction motor: Induction Reversible Speed control Magnetic brake Torque
 DC brushless motor: BMS Series BS Series SBS Series UBS Series DBS Series
 Stepping motor: 2 phase 3 phase 5 phase

【Drive mechanism and operating data】 : Use the space below to draw the outline of your drive mechanism and fill in the operating conditions required

Recommendation products (Selected specs) :

※ After complete above information, please fax it to nearby regional business office, we will select applicable product for you as soon as possible