





DBS series

-The situation needs DC power control

Page

- | | |
|----|--|
| 61 | Specifications and characteristics of Motor/Driver |
| 62 | Gearhead specifications & allowable speed range/allowable torque/allowable inertia load (GD^2) |
| 63 | Motor allowable radial load/axial load |
| 64 | Speed - Torque characteristic diagrams |
| 65 | Driver panel functions and wiring instructions |
| 66 | Motor electromagnetic brake wiring instructions |
| 67 | Dimensions - Motor/Gearhead |
| 69 | Dimensions - Driver |
| 69 | Dimensions - Variable resistor |

■ Specifications and characteristics of Motor/Driver

Motor output power		20W	40W	60W	100W	
Round shaft Motor (M: E/M brake type)		6B020S-D(M)	6B040S-D(M)	9B060S-D(M)	9B100S-D(M)	
Pinion shaft Motor (M: E/M brake type)		6B020P-D(M)	6B040P-D(M)	9B060PD-D(M) 9B060PH-D	9B100PD-D(M) 9B100PH-D	
Motor specification certificate		 ※9B060PH-D、9B100PH-D no RoHS certificate				
Driver		DBD020-D	DBD040-D	DBD060-D	DBD100-D	
Driver specification certificate						
Input Power Voltage	DC23~26V	Current Min.(A)	2	4	6	10
		Rated current(A)	1.48	3.65	4.37	6.73
Starting Torque (Nm)		0.08	0.16	0.25	0.4	
Rated Torque (Nm)		0.07	0.14	0.2	0.33	
Allowable load inertia GD ² (Kgcm ²)		4.78	9.55	11.3	20.8	
E/M Brake	※ Only E/M brake series have E/M	Input power voltage(V)	DC24		DC24	
		Consumption power(W)	6.5		7.5	
		Maintenance(Nm)	0.3		0.5	
		Attraction time(ms)	30		33	
		Release time(ms)	87		95	
Speed control range(r/min)		250~3000				
To load		-2%Max.	In 3000r / min, no-load ~rated load			
Speed variation rate To voltage		±2%	Power voltage variation DC24V ± 10%, while in 3000r / min with no load			
To Temperature		±3%	When 0 ~ + 40 ° C, at 3000r / min, while no load			
Slow start/Slow down time set up		When slow start 0.5 ~ 10 sec, Motor from the 0 ~ 3000r / min, while no load When slow stop 0.5 ~ 5 sec, Motor from the 3000 ~ 0r / min, while no load				
Speed control method		<ul style="list-style-type: none"> •Controlled by an external variable resistor (resistance value 20KΩ) •Controlling by internal variable resistor (1mA or more) •By an external DC voltage control (DC0 ~ 5V) •Can be used with D / A speed setter TRAC (optional) 				
Signal input/output method		<ul style="list-style-type: none"> •Photo coupler(PHOTO COUPLER) •Open collector transistor circuit(OPEN COLLECTOR) output interface 				
Function		<ul style="list-style-type: none"> •Contactless control (ZERO POINT), direct PLC or transistor type, relay-style I / O modules •Within speed control range, Motor constant torque output (FLAT TORQUE) •Instantaneous brake stop, slow start/slow stop (SLOW START/SLOW DOWN) •When brake stop all electrical type cage effect 				
Protection function		Protection function will be the following two kinds of situation: ○Motor will naturally stop, Driver ALARM contact signal output <ul style="list-style-type: none"> •Overload Protection: Exceeding the rated torque of Motor running more than 7 seconds, it operates •Low voltage Protection: Driver input AC power voltage less than about 20%, it operates •Offline Protection: When Motor cable disconnected, it operates •Internal automatic disconnection from multiple fuse, and disconnect power supply of internal controller, POWER light goes out •Over voltage protection: When Driver input DC power voltage exceeds about 25%, it operates •Reverse power protection: DC power voltage polarity is reversed, it operates polarity 				
Insulation impedance	Motor	When using DC500V megger test, the impedance between coil and housing is more than 100MΩ				
	Driver	When using DC500V megger test between power input terminal and cabinet impedance value is above 100MΩ				
Insulation pressure	Motor	Between coil and casing, through to AC 1.8KV / 60Hz high pressure, sustained 1sec, no abnormal condition				
	Driver	Between power input terminal and cabinet, through to AC 0.5KV / 60Hz high pressure, for 1 minute, no abnormal condition				
Ambient temperature/Humidity range		Motor 0 ~ + 50 ° C, Driver 0 ~ + 40 ° C, 85% RH or less (to avoid dust and corrosive, flammable gas)				

*1 Nm=10.19716 Kgcm



■ Gearhead specifications & allowable speed range/allowable torque/allowable inertia load (GD²)

Gear ratio		3	3.6	5	6	7.5	9	10	12.5	15	18	20	25	30
Speed range (r/min)	High speed	1000	883	600	500	400	333	300	240	200	166	150	120	100
	Low speed	83.4	69.5	50	41.7	33.4	27.8	25	20	16.7	13.9	12.5	10	8.4
Allowable torque (Nm)	6B020P-D(M) + 6D□	0.18	0.21	0.29	0.35	0.44	0.53	0.59	0.73	0.88	1.1	1.2	1.4	1.7
Allowable inertia load GD ² (kgcm ²)		2.25	3.24	6.25	9.00	14.1	20.3	25.0	39.1	56.3	81.0	100	156	225
Allowable torque (Nm)	6B040P-D(M) + 6D□	0.35	0.42	0.59	0.7	0.88	1.1	1.2	1.5	1.8	2.1	2.3	2.8	3.4
Allowable inertia load GD ² (kgcm ²)		4.50	6.48	12.5	18.0	28.1	40.5	50.0	78.1	113	162	200	313	450
Allowable torque (Nm)	9B060PD-D(M) + 9D□	0.54	0.65	0.9	1.1	1.4	1.6	1.8	2.3	2.7	3.2	3.6	4.3	5.2
Allowable inertia load GD ² (kgcm ²)		18.0	25.9	50.0	72.1	113	162	200	313	450	649	801	1251	1802
Allowable torque (Nm)	9B060PH-D + 9D□H	0.54	0.65	0.9	1.1	1.4	1.6	1.8	2.3	2.7	3.2	3.6	4.3	5.2
Allowable inertia load GD ² (kgcm ²)		181	260	501	722	1128	1624	2006	3134	4512	6498	8022	12534	18050
Allowable torque (Nm)	9B100PD-D(M) + 9D□	0.89	1.1	1.5	1.8	2.2	2.7	3.0	3.7	4.5	5.3	5.9	7.1	8.5
Allowable inertia load GD ² (kgcm ²)		33.3	48.0	92.5	133	208	300	370	578	832	1199	1480	2312	3330
Allowable torque (Nm)	9B100PH-D + 9D□H	2.2	2.6	3.6	4.3	5.4	6.5	7.2	9	10.8	13	14.4	17.2	20.6
Allowable inertia load GD ² (kgcm ²)		181	260	501	722	1128	1624	2006	3134	4512	6498	8022	12534	18050

Gear ratio		36	50	60	75	90	100	120	150	180	200	250	300	360	
Speed range (r/min)	High speed	83	60	50	40	33	30	25	20	16	15	12	10	8	
	Low speed	7	5	4.2	3.4	2.8	2.5	2.1	1.7	1.4	1.3	1	0.9	0.7	
Allowable torque (Nm)	6B020P-D(M) + 6D□	2	2.8	3.4	4.2	5	5.6	6.3	6.5						
Allowable inertia load GD ² (kgcm ²)		324	625						625						
Allowable torque (Nm)	6B040P-D(M) + 6D□	4	5.6	6.5						6.5					
Allowable inertia load GD ² (kgcm ²)		625						625							
Allowable torque (Nm)	9B060PD-D(M) + 9D□	6.2	8.6	10.3	12.9	15.5	17.2	19.4	24.3	29.2	32.4	40			
Allowable inertia load GD ² (kgcm ²)		2594	5004	7206	11000			11000							
Allowable torque (Nm)	9B060PH-D + 9D□H	6.2	8.6	10.3	12.9	15.5	17.2	19.4	24.3	29.2	32.4	40			
Allowable inertia load GD ² (kgcm ²)		25991	45000						45000						
Allowable torque (Nm)	9B100PD-D(M) + 9D□	10.2	14.2	17	21.3	25.5	28.4	32.1	40						
Allowable inertia load GD ² (kgcm ²)		4795	9249	11000				11000							
Allowable torque (Nm)	9B100PH-D + 9D□H	24.8	34.4	41.3	50			50							
Allowable inertia load GD ² (kgcm ²)		25991	45000						45000						

* Gearhead 6D□/9D□/9D□H, please fill gear ratio in □.

* ■ In above table stands for after installation of Gearhead, the axis rotation is reversed with Motor axis direction; without marking stands for the same direction as Motor axis rotation.

* 1 Nm=10.19716 Kgcm

* In addition to Gearhead 9D□H120~360 without certificate, other series of Gearhead have certificate

* Also available orthogonal Gearhead: hollow shaft type 9VD□(H), the solid single shaft type 9VD□A(H), the solid biaxial shaft type 9VD□B(H), and size please refer to P.10.

Motor allowable radial load/axial load

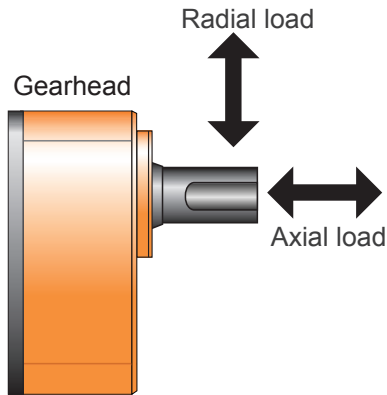

- ① Radial load (hanging load): loading is vertical to Gearhead axis power output
- ② Axial load (thrust load): loading is in the direction of Gearhead axis power output

◆ Round shaft type

Model	Permissible overhung load (Unit: Kg f)		Permissible thrust load (Unit: Kg f)
	10mm from output shaft front	20mm from output shaft front	
6B020S-D(M)	8	9	Permissible axial loading, not more than 1/2 of Motor weight. But please try to avoid applying force in the horizontal direction (axial) of motor shaft, when exceeds that will reduce Motor service life. If axial loading is needed, we recommend applying indirect transmission, such as: couplings, belts, chains, etc...
6B040S-D(M)	8	9	
9B060S-D(M)	16	17	
9B100S-D(M)	16	17	

◆ Pinion shaft type (Gearhead attached)

Model	Gear ratio	Permissible overhung load (Unit: Kg f)		Permissible thrust load (Unit: Kg f)
		10mm from output shaft front	20mm from output shaft front	
6B020P-D(M) + 6D□	3, 3.6, 5	10	15	4
	6, 7.5, 9, 10, 12.5, 15, 18, 20	15	20	
6B040P-D(M) + 6D□	25, 30, 36, 50, 60, 75, 90, 100, 120, 150, 180, 200, 250, 300, 360	20	30	
9B060PD-D(M)+9D□ 9B060PH-D+9D□H 9B100PD-D(M)+9D□ 9B100PH-D+9D□H	3, 3.6, 5	30	40	15
	6, 7.5, 9, 10, 12.5, 15, 18, 20	40	50	
	25, 30, 36, 50, 60, 75, 90, 100, 120, 150, 180, 200, 250, 300, 360	50	65	

* Gearhead 6D□/9D□/9D□H, please fill gear ratio in□



■ Speed - Torque characteristic diagrams

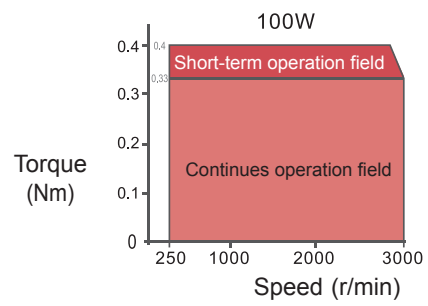
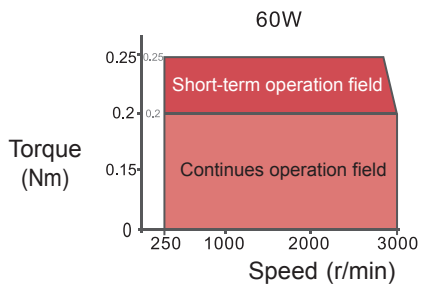
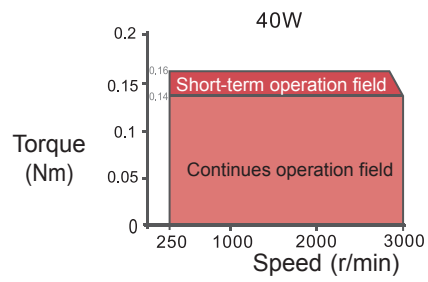
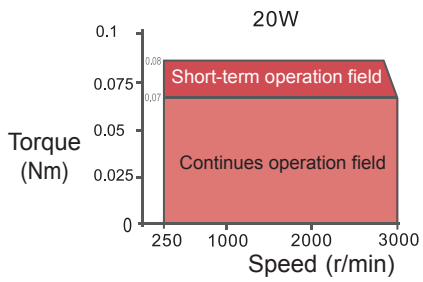

Driver panel functions and wiring instructions

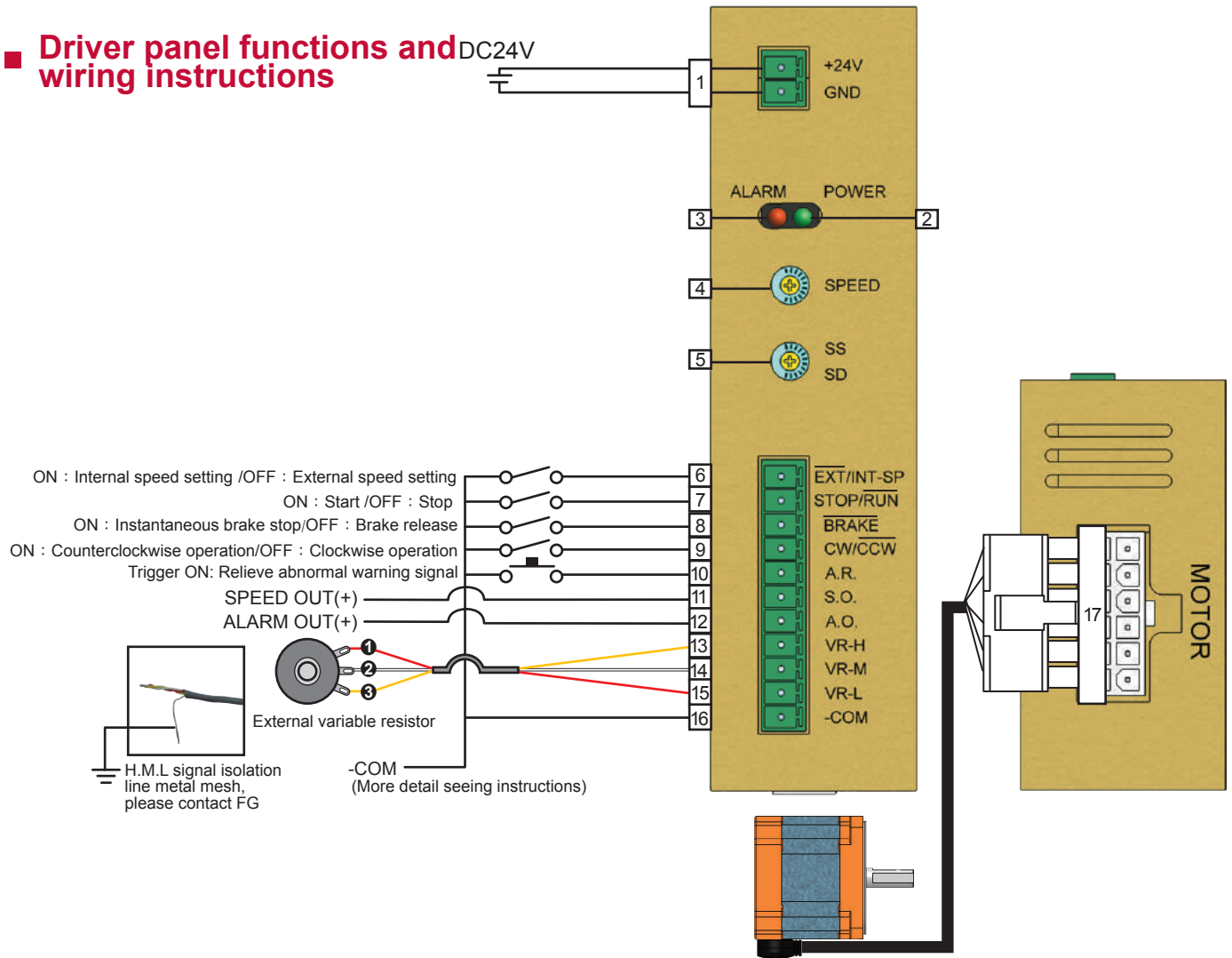

Number	Panel marked	Function	Explanation
1	+24V \ GND	DC power voltage input terminal	DC power voltage input connection
2	POWER	Power indicator	LED (green) lights when input power
3	ALARM	Unusual indicator	Overload, low voltage, disconnection any protective function is activated LED (red) lights
4	SPEED	Internal speed setting button	20 ~ 100W speed control range: 250 ~ 3000r/min
5	SS/SD	Slow start, stop time setting button	Slow start 0.5 ~ 10 sec; slow stop 0.5 ~ 5 sec
6	EXT/INT-SP	Speed setting switch to select the input mode	External/internal speed setting mode switch selection
7	STOP/RUN	Stop/start signal input	Stop/start signal switch input
8	BRAKE	Instantaneous brake stop signal input	Executive instantaneous brake stop / brake release signal switch input
9	CW/CCW	The direction of rotation switch to select input	CW/CCW operation switch selection
10	A.R.	Abnormal warning signal release input	A.R. trigger input contacts (Length "L" state 10ms) to release the error of warning signal
11	S.O.	Speed signal output	Using while monitoring Motor speed, digital signal output 12Pulse/rev
12	A.O.	Abnormal warning signal output	Overload, low voltage, disconnection any protective function is activated, Motor stops naturally, and outputs an abnormality warning signal.
13	VR-H	Motor wiring connector	An external connection terminal variable resistor or external DC voltage (0 ~ 5V) control of speed control range: 250 ~ 3000r / min
14	VR-M		
15	VR-L		
16	-COM	Control signal grounding	GND contact inputs and outputs a control signal common ground wire, and the external DC power contact
17	MOTOR	Motor wiring connector	Motor and Driver connection



■ Electromagnetic brake wiring instructions

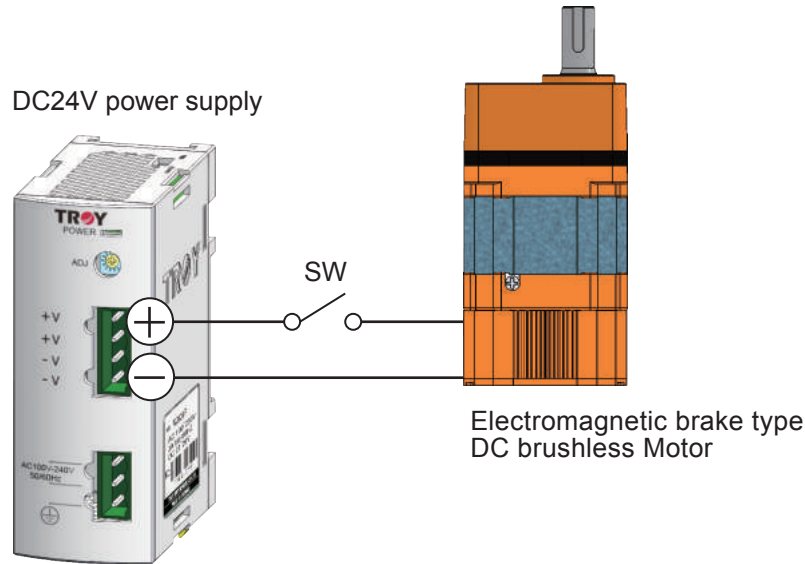

◆ Operation instruction

Motor start/Motor stop with external electromagnetic brake operating procedures:

Motor start: Must energize external electromagnetic brake before the Motor starts

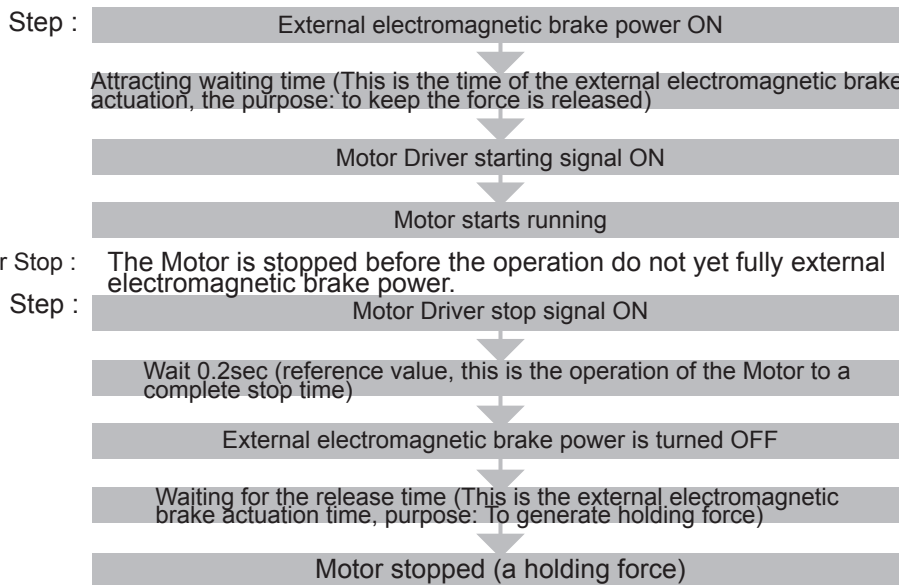

◆ Precautions

- 1.This series of external electromagnetic brake using the brake power is part of the hold-type.
- 2.External electromagnetic brake is designed to allow the Motor stops when the holding force has to be used as a safety brake, electromagnetic brake, do not use this as a Motor positioning or emergency brake applications.
- 3.Always to pull the Motor before starting the external electromagnetic brake energized (means no brakes); Motor stopped before the operation do not yet fully external electromagnetic brake power (expressed brakes).
- 4.External electromagnetic brake suction time and release time value refer to the product specification.
- 5.Motor brakes to stop for about 0.2sec (test conditions in the Motor no-load speed 3000r / min, the electromagnetic brake is energized, the brake actuator signal ON time of the Driver, this time as a reference base, but the actual length of time will stop according to the inertia load or frictional load ... different load patterns and has fluctuated.
- 6.We recommend to do the actual measuring device operating time at the time of commissioning.

■ Dimensions - Motor/Gearhead

Unit : mm

Round shaft type

Gear shaft type

60W/□90mm

◆ 9B060S-D

Weight : 655g

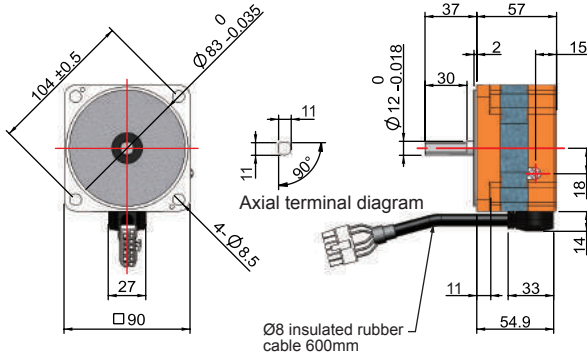

◆ 9B060PD-D + 9D□

Weight : 1500g+W

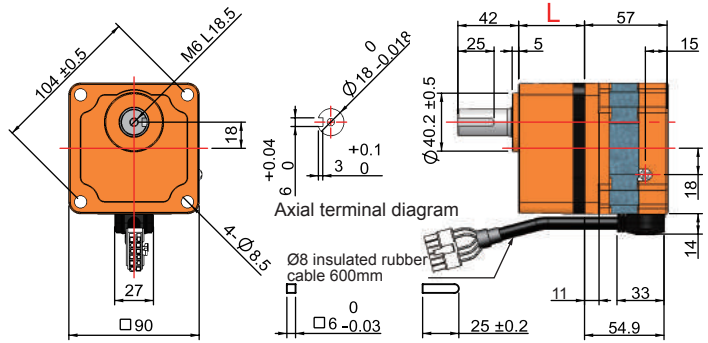

◆ 9B060S-DM

Weight : 2275g

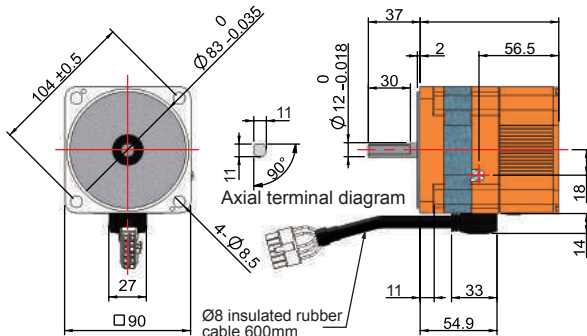

◆ 9B060PD-DM + 9D□

Weight : 2250g+W

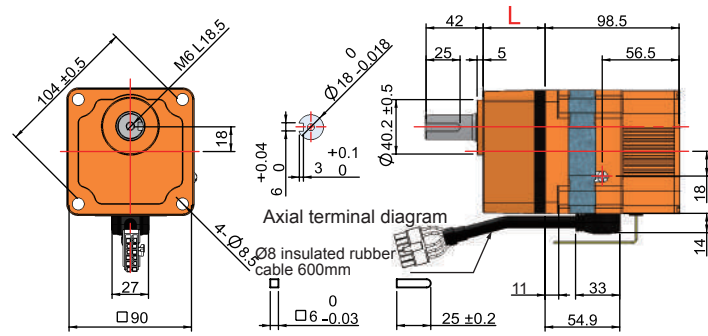

100W/□90mm

◆ 9B100S-D

Weight : 1525g

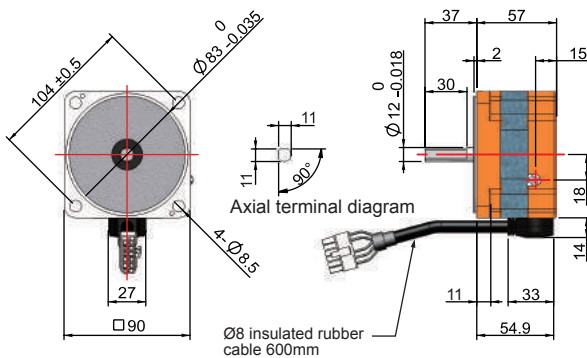

◆ 9B100PD-D + 9D□

Weight : 1500g+W

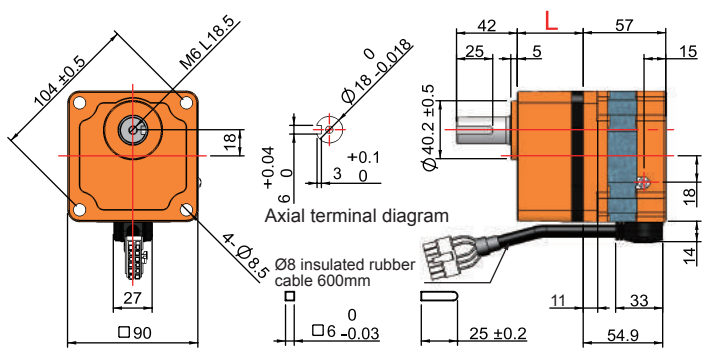

◆ 9B100S-DM

Weight : 2275g

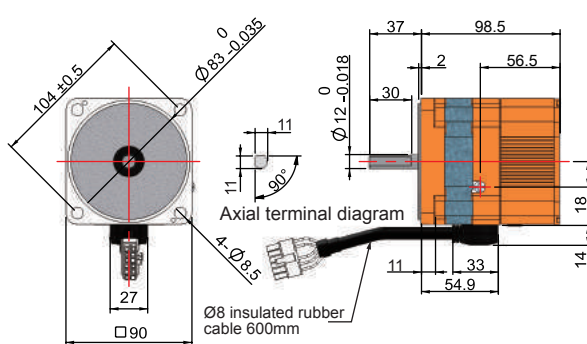

◆ 9B100PD-DM + 9D□

Weight : 2250g+W

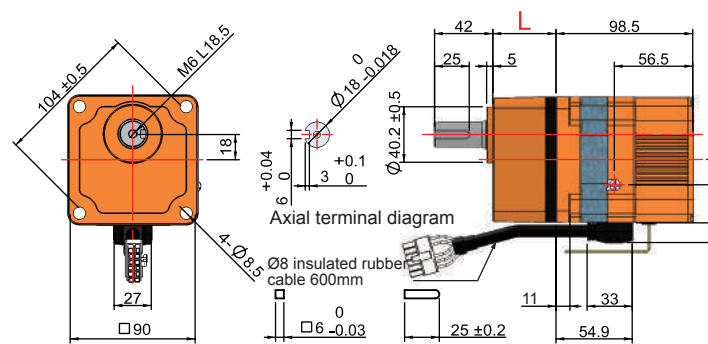

* Figure above dimensions tolerance values are not labeled a general machining tolerances, the control mode, refer to P.12, others have marked tolerance values according to the drawing labeled based.

* 9B pinion shaft type 9D3-9D360, Gearhead length L and weight W specification as following:

Model	9D3~9D20	9D25~9D100	9D120~9D360
Gearhead Length L (mm)	45.5	58.5	64.5
Weight W (g)	860	1125	1265

TRV-
Characteristics of Motor
Product index
Product names
Product weight
Gearhead
Installation
Certificates
Model naming
BMS
BS
SSS
CAS
Accessories
Motor selection

■ Dimensions - Driver

Unit : mm

Model : DBD020-D / DBD040-D
Weight : 210g
Dimensions are common

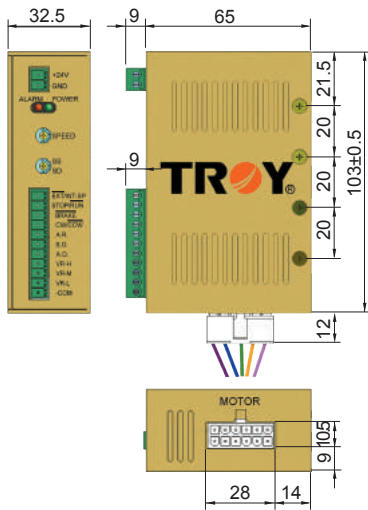

Model : DBD060-D / DBD100-D
Weight : 290g
Dimensions are common

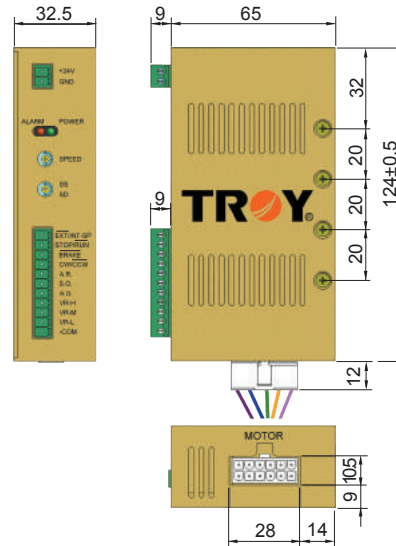

Mounting sheet

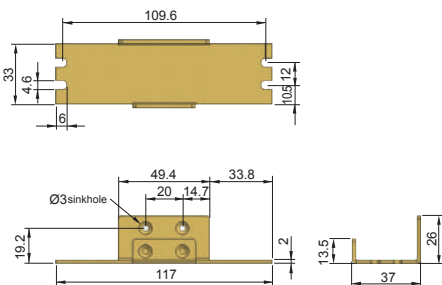

Mounting sheet

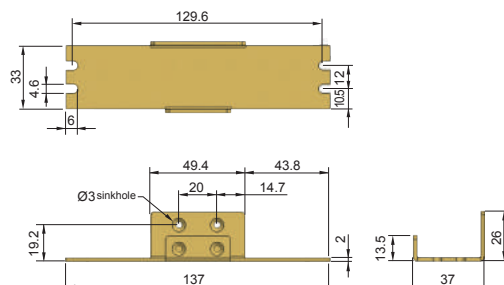

■ Dimensions - Variable resistor

Weight : 30g

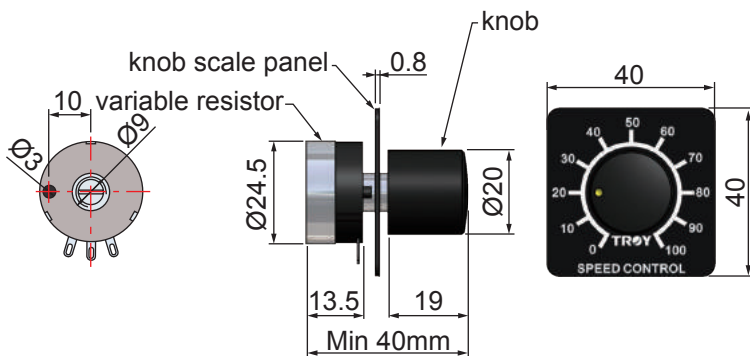

* Figure above dimensions tolerance values are not labeled a general machining tolerances, the control mode, refer to P.12, others have marked tolerance values according to the drawing labeled based.

Motor selection sheet

■ Mechanism: [Operating of large index table]

Date dd / mm / yy

Company name: _____ Contact person: _____ Department/Title: _____

TEL: _____ FAX: _____ Application: _____ Use area: _____

Power input: Single -phase AC: ___ V Three -phase AC: ___ V DC: ___ V Frequency: Hz

Activated mode: Single direction operating continuously → Rated speed
 Regulated speed (Range: ___ rpm ~ ___ rpm)
 Single direction run 、 stop 、 run 、 stop → (Activated time: ___ Second/Sequence, stop time: ___ Second/Sequence; Run, stop total ___ Sequence /Minutes)
 Clockwise/counter clockwise repeated → (CW: ___ Second/Sequence 、 Stop: ___ Second/Sequence 、 CCW: ___ Second/Sequence 、 Stop: ___ Sequence/Minute)

Required motor: AC induction motor: Induction Reversible Speed control Magnetic brake Torque
 DC brushless motor: BMS Series BS Series SBS Series UBS Series DBS Series
 Stepping motor: 2 phase 3 phase 5 phase

【Mechanism reference】

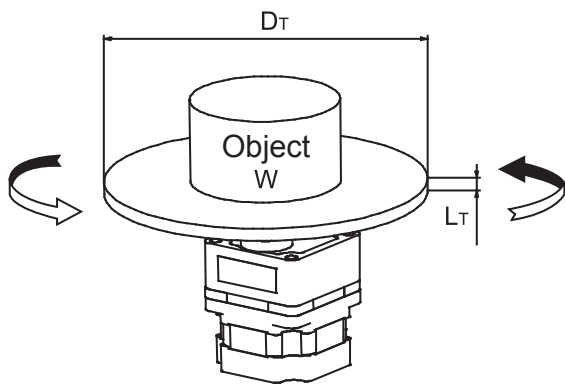

【Please sketch your actual transmission part of mechanism】

【Drive mechanism and operating data】

Object mass	W = _____ kg
Index table diameter	D _T = _____ cm
Width	L _T = _____ cm
Material	ρ = _____
Positioning angle *(note)	θ = _____ deg
Positioning time *(note)	T ₀ = _____ sec
Stopping accuracy	± _____ mm

*(note)Please enter the max speed

Recommendation products (Selected specs) :

After complete above information, please fax it to nearby regional business office, we will select applicable product for you as soon as possible

Motor selection sheet

■ Mechanism: 【Lead screw】

Date dd / mm / yy

Company name: _____ Contact person: _____ Department/Title: _____

TEL: _____ FAX: _____ Application: _____ Use area: _____

Power input: Single -phase AC: ___V Three -phase AC: ___V DC: ___V Frequency: Hz

Activated mode: Single direction operating continuously → Rated speed
 Regulated speed (Range: ___ rpm ~ ___ rpm)
 Single direction run、stop、run、stop → (Activated time: ___ Second/Sequence, stop time: ___ Second/Sequence; Run, stop total ___ Sequence /Minutes)
 Clockwise/counter clockwise repeated → (CW: ___ Second/Sequence、Stop: ___ Second/Sequence、CCW: ___ Second/Sequence、Stop: ___ Sequence/Minute)

Required motor: AC induction motor: Induction Reversible Speed control Magnetic brake
 Torque
 DC brushless motor: BMS Series BS Series SBS Series UBS Series
 DBS Series
 Stepping motor: 2 phase 3 phase 5 phase

【Mechanism reference】

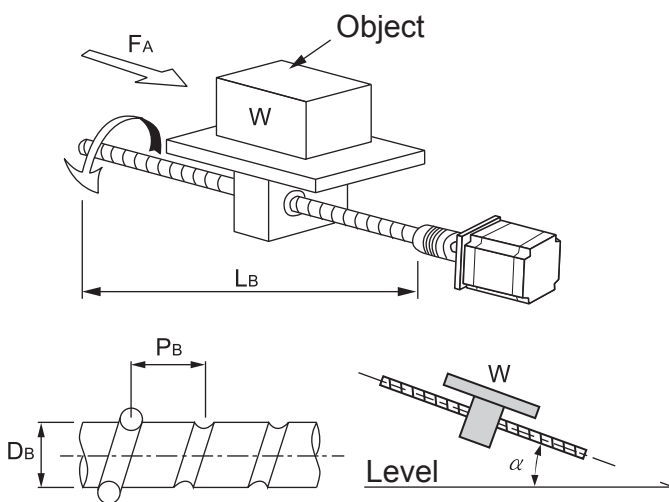

【Please sketch your actual transmission part of mechanism】

【Drive mechanism and operating data】

Work+Table mass	W = _____ kg	frictional coefficient of sliding surfaces	$\mu =$ _____
Screw angle	$\alpha =$ _____ deg	Positioning distance	L = _____ cm
Screw shaft diameter	$D_B =$ _____ cm	Positioning time	$T_O =$ _____ sec
Screw Length	$L_B =$ _____ cm	Push / Pull force	$F_A =$ _____ kg
Screw pitch	$P_B =$ _____ cm	Stopping accuracy	\pm _____ mm
Material	$\rho =$ _____		
Screw efficiency	$\eta =$ _____		
Internal frictional coefficient of pilot pressure nut	$\mu_0 =$ _____		

*(note)Please enter the max speed

Recommendation products (Selected specs) :

* After complete above information, please fax it to nearby regional business office, we will select applicable product for you as soon as possible

This page can be copied

Motor selection sheet

■ Mechanism: **[Belt and pulley]**

Date dd / mm / yy

Company name: _____ Contact person: _____ Department/Title: _____

TEL: _____ FAX: _____ Application: _____ Use area: _____

Power input: Single -phase AC: V Three -phase AC: V DC: V Frequency: Hz

Activated mode: Single direction operating continuously → Rated speed
 Regulated speed (Range: rpm ~ rpm)
 Single direction run、stop、run、stop → (Activated time: Second/Sequence, stop time: Second/Sequence; Run, stop total Sequence /Minutes)
 Clockwise/counter clockwise repeated → (CW: Second/Sequence、Stop: Second/Sequence、CCW: Second/Sequence、Stop: Sequence/Minute)

Required motor: AC induction motor: Induction Reversible Speed control Magnetic brake Torque
 DC brushless motor: BMS Series BS Series SBS Series UBS Series DBS Series
 Stepping motor: 2 phase 3 phase 5 phase

【 Mechanism reference 】

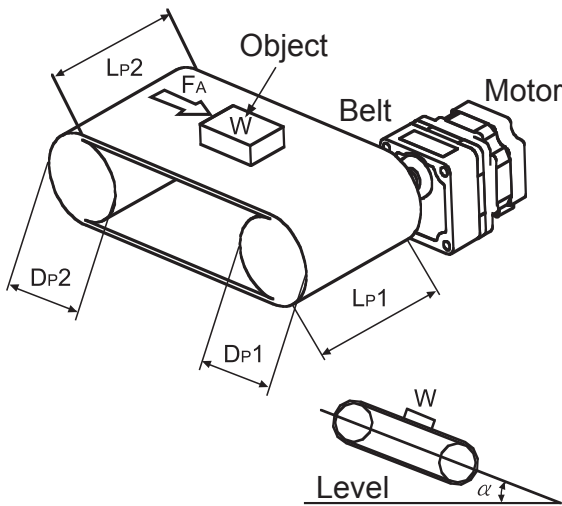

【 Please sketch your actual transmission part of mechanism 】

【 Drive mechanism and operating data 】

Work + Table + Pulley	$W = \text{_____ kg}$	Belt、pulley efficiency	$\eta = \text{_____}$
Screw angle	$\alpha = \text{_____ deg}$	frictional coefficient of sliding surfaces	$\mu = \text{_____}$
Pulley diameter	$D_{P1} = \text{_____ cm}$	Positioning distance *(note)	$L = \text{_____ cm}$
Width	$L_{P1} = \text{_____ cm}$	Positioning time *(note)	$T_O = \text{_____ sec}$
Material	$\rho 1 = \text{_____}$	Push / Pull force	$F_A = \text{_____ kg}$
Pulley diameter	$D_{P2} = \text{_____ cm}$	Stopping accuracy	$\pm \text{_____ mm}$
Width	$L_{P2} = \text{_____ cm}$		
Material	$\rho 2 = \text{_____}$	*(note)Please enter the max speed	

Recommendation products (Selected specs) :

※ After complete above information, please fax it to nearby regional business office, we will select applicable product for you as soon as possible

This page can be copied

TRV-
 Characteristics of Motor
 Product index
 Product names
 Product weight
 Technical Information
 Gearhead
 Installation
 Certificates
 Model naming
 BMS
 BS
 SBS
 CBS
 DBS
 Accessories
 Motor selection

Motor selection sheet

■ Mechanism: [Others]

Date dd / mm / yy

Company name: _____ Contact person: _____ Department/Title: _____

FAX: _____ Application: _____ Use area: _____

Power input: Single -phase AC: ___V Three -phase AC: ___V DC: ___V Frequency: Hz

Activated mode: Single direction operating continuously → Rated speed
 Regulated speed (Range: ___ rpm ~ ___ rpm)
 Single direction run、stop、run、stop → (Activated time: ___ Second/Sequence, stop time: ___ Second/Sequence; Run, stop total ___ Sequence /Minutes)
 Clockwise/counter clockwise repeated → (CW: ___ Second/Sequence、Stop: ___ Second/Sequence、CCW: ___ Second/Sequence、Stop: ___ Sequence/Minute)

Required motor: AC induction motor: Induction Reversible Speed control Magnetic brake Torque
 DC brushless motor: BMS Series BS Series SBS Series UBS Series DBS Series
 Stepping motor: 2 phase 3 phase 5 phase

【Drive mechanism and operating data】 : Use the space below to draw the outline of your drive mechanism and fill in the operating conditions required

Recommendation products (Selected specs) :

※ After complete above information, please fax it to nearby regional business office, we will select applicable product for you as soon as possible