

SPEED CONTROL UNIT

NEW H-SERIES

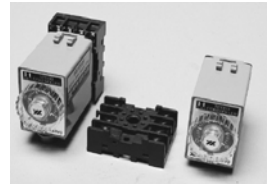

SPEED CONTROL UNIT

CONNECTOR TYPE

Q-CON HC

■GENERAL SPECIFICATION

可變速度範圍 90~1400rpm(50Hz), 90~1700rpm(60Hz)

TACHO GENERATOR付 Q-CON MOTOR

- 速度設定器內裝
CASE 前面의 速度設定用 可變抵抗器로 回轉速度를 設定
- CONNECTOR로 ONE TOUCH 接續
(OPTION의 連結CORD로 最大 5m까지 延長可能)
- Speed controller with tacho-generator
- Built-in speed setting
- One-touch connection by 8 pin connector
(extension cord 5m long max, optional)



■PERFORMANCE DATA

| MOTOR TYPE | HC□I-11G | HC□I-11Y | HC□I-22G | HC□I-22Y |
|--------------------|-----------------------------|----------|----------|----------|
| RATED VOLTAGE | 110V | | 220V | |
| VOLTAGE RANGE | RATED VOLTAGE ± 10 % | | | |
| LINE FREQ. | 50 / 60 Hz | | | |
| MOTOR OUTPUT | 6 ~120 W | | | |
| TG VOLTAGE | 24 V | 12 V | 24 V | 12 V |
| SPEED RANGE | 90 ~1400 rpm / 90 ~1700 rpm | | | |
| SPEED VARIATION | 5 % (STANDARD) | | | |
| SPEED SETTING | BUILT-IN | | | |
| PARALLEL OPERATION | NOT APPLICABLE | | | |
| SLOW UP · DOWN | NOT APPLICABLE | | | |
| OPERATION TEMP. | -10 ~ 40 °C | | | |
| STORAGE TEMP. | -20 ~ 60 °C | | | |
| HUMIDITY | BELOW 85 % | | | |

OUTLINE DIMENSION

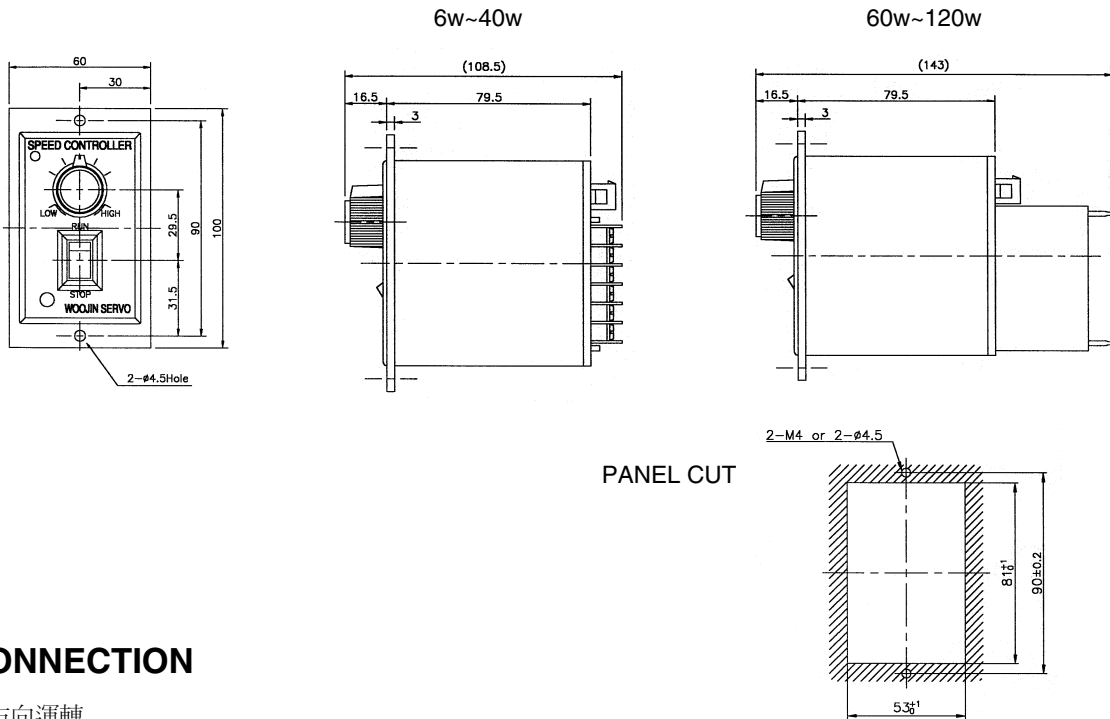

CONNECTION

· 一方向運轉

SPEED CONTROLLER 뒷면 端子臺의 結線을 바꾸면 回轉方向이 反對로 됩니다.

正方向運轉 : 端子臺의 “COM” 과 “CW” 를 接續합니다.

逆方向運轉 : 端子臺의 “COM” 과 “CCW” 를 接續합니다.

· 正逆運轉

“CW” · “CCW” 端子에 SWITCH를 連結하여 正 · 逆運轉을 할수 있습니다.

· 延長CORD

標準MOTOR의 LEAD선 길이는 250mm입니다.

이보다 먼곳에 MOTOR를 設置할때는 延長 CORD(OPTION으로 供給함)를 使用하십시오.

延長 CORD의 길이는 0.5m, 1m, 2m, 3m, 4m, 5m입니다.

- For CW operation, please connect terminal “COM” and “CW”
- For CCW operation, please connect terminal “COM” and “CCW”
- For reversible operation, please install change-over switch as shown on drawing.
- Extension cord(optional) is conveniently used when motor is located more than 250mm apart from control unit. Standard length is 0.5, 1m, 2m, 3m, 4m and 5m(max).

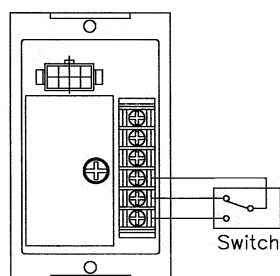

SWITCH

SINGLE POLE CHANGE-OVER SWITCH

FOR INPUT 110V : 250V AC 5A

220V : 400V AC 3A

SPEED CONTROL UNIT

PLUG-IN TYPE

Q-CON HS

■ GENERAL SPECIFICATION

가변속도범위 90~1400rpm (50Hz), 90~1700rpm (60Hz)

TACHO GENERATOR부 Q-CON MOTOR

- 속도설정기내장
CASE전면의 속도설정용 가변저항기로 회전속도를 설정
(외부저항기로 별도의 속도설정도 가능함)
- 전기 BRAKE에 의한 순시정지기능이 가능함
- 표준4각 8P SOCKET 사용(원형 SOCKET도 사용가능)

- Speed Controller with Tacho Generator
- Plug-in type for standard 8 pin socket
- Built-in speed setting (external speed setting applicable)
- Instantaneous stop by electric brake circuit
- Various application

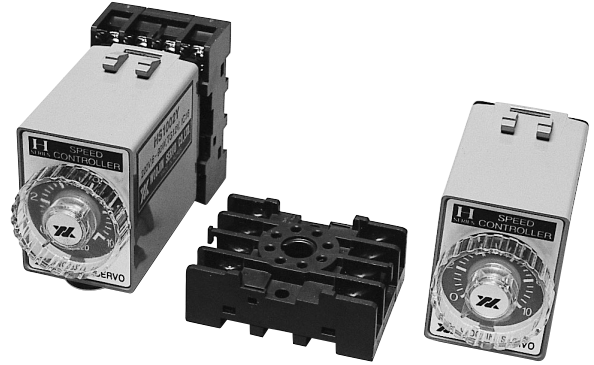

■ PERFORMANCE DATA

| CONTROLLER | HS□-11-G | HS□-11-Y | HS□-22-G | HS□-22-Y |
|--------------------|--|----------|----------|----------|
| RATED VOLTAGE | 110V | | 220V | |
| VOLTAGE RANGE | RATED VOLTAGE ± 10 % | | | |
| LINE FREQ. | 50 / 60 Hz | | | |
| MOTOR OUTPUT | 6 ~120 W, 120W | | | |
| TG VOLTAGE | 24 V | 12 V | 24 V | 12 V |
| SPEED RANGE | 90 ~1400 rpm / 90 ~1700 rpm | | | |
| SPEED VARIATION | 5 % (STANDARD) | | | |
| SPEED SETTING | BUILT-IN(EXTERNAL SETTING ATTATCHABLE) | | | |
| BRAKE | ELECTRIC(BY BREAKING CURRENT) | | | |
| BRAKE TIME | 0.5 sec (STANDARD) | | | |
| PARALLEL OPERATION | NOT APPLICABLE | | | |
| SLOW UP · DOWN | NOT APPLICABLE | | | |
| OPERATION TEMP. | -10 ~ 40 °C | | | |
| STORAGE TEMP. | -20 ~ 60 °C | | | |
| HUMIDITY | BELOW 85 % | | | |

OUTLINE DIMENSION

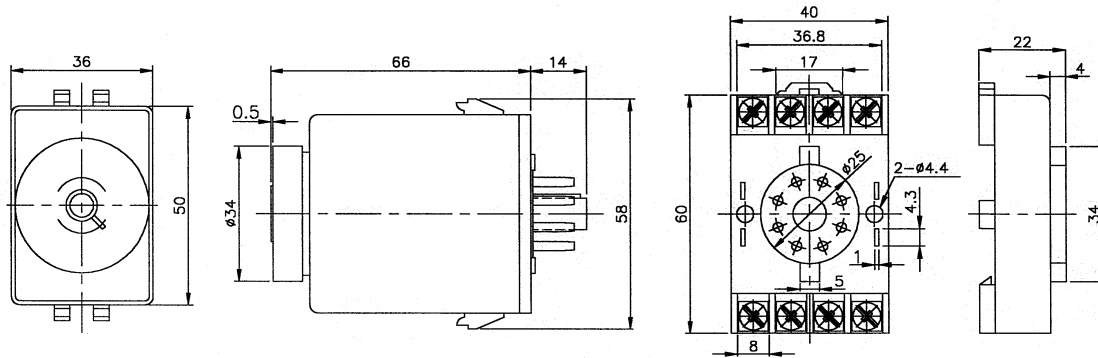

WIRING DIAGRAM

① INDUCTION (一方向運轉) + VARIABLE SPEED (變速) 6w ~ 120w

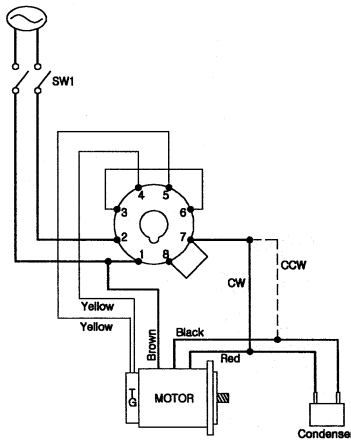

- * 1 굵은 실선은 MOTOR의 회전방향이 축끝에서 보아 시계방향(CW)입니다
반시계방향(CCW)은 점선의 결선으로 하십시오

SW1 : AC125V or AC250V 5A

- To reverse the rotation from "CW" to "CCW", change the connection as per dotted line.

② INDUCTION + VARIABLE SPEED + BRAKE (制動) 6w ~ 25W

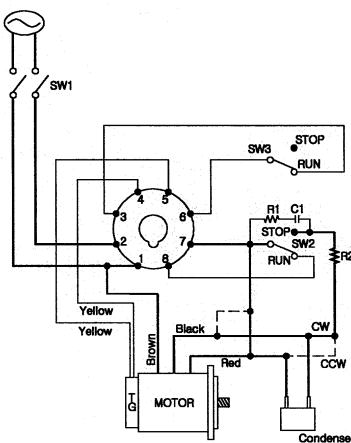

- * 1 굵은 실선은 MOTOR의 회전방향이 축끝에서 보아 시계방향(CW)입니다
반시계방향(CCW)은 점선의 결선으로 하십시오

- 2 RUN에서 STOP으로하면 제동(전기BRAKE)이 약0.5초간 작동하여 MOTOR가 순시정지합니다.

SW1, SW 2 : AC125V or AC250V 5A

SW3 : DC 10V 10mA

R1 : 10 ~ 200Ω 1/4w min.

C1 : 0.1 ~ 0.33μF
AC125V(INPUT 110V)
AC250V(INPUT 220V)

R2 : 5.6Ω 10w

- To reverse the rotation from "CW" to "CCW", change the connection as per dotted line.
- When switch from "RUN" to "STOP", electric brake acts for approx. 0.5sec and motor stops instantaneously.

③INDUCTION(一方向運轉) + VARIABLE SPEED(變速) + BRAKE(制動) 40w~120w

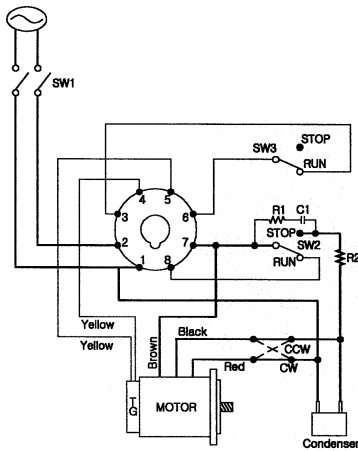

- * 1 굵은 실선은 MOTOR의 회전방향이 축끝에서 보아 시계방향(CW)입니다.
반시계방향(CCW)은 점선의 결선으로 하십시오
- 2 RUN 에서 STOP 으로하면 제동(전기BRAKE)가 약 0.5초간 작동하여 MOTOR가 순시정지합니다.

SW1 SW 2 : AC125V or AC250V 5A
 SW3 : DC 10V 10mA
 R1 : 10~200Ω 1/4W min.
 C1 : 0.1~0.33μF
 AC125V(INPUT 110V)
 AC250V(INPUT 220V)
 R2 : 5.6Ω 10W

- To reverse the rotation from “CW” to “CCW”, change the connection as per dotted line.
- When switch from “RUN” to “STOP”, electric brake acts for approx. 0.5sec and motor stops instantaneously.

④REVERSIBLE(正·逆運轉) + VARIABLE SPEED(變速) 6w~120w

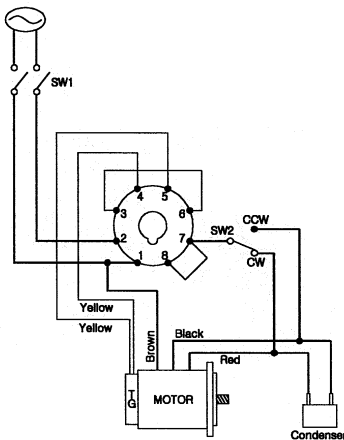

- * 1 정지시간을 설정하여 회전이 정지한후 SW2를 절채 하십시오

SW1, SW 2 : AC125V or AC250V 5A

- Operate SW2 after motor stops completely.

⑤REVERSIBLE(定·逆運轉) + VARIABLE SPEED(變速) + BRAKE(制動) 6w~25w

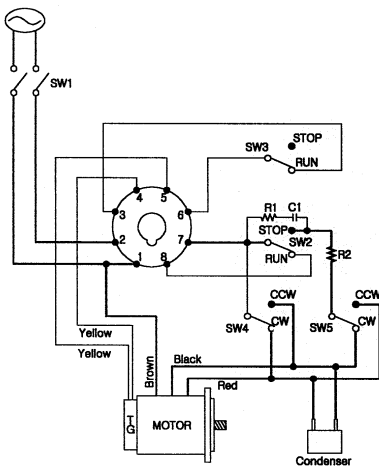

- * 1 RUN 에서 STOP 으로하면 제동(전기BRAKE)가 약 0.5초간 작동하여 MOTOR가 순시정지합니다
- 2 이 0.5초동안은 SW4, SW5를 조작하지 마십시오
- 3 SW4, SW5의 절채는 SW2, SW3의 STOP에서 RUN의 절채 보다 빨리 하십시오.

SW1, SW2 : AC125V or AC250V 5A
 SW3 : DC 10V 10mA
 SW4, SW5 : AC125V or AC250V 5A
 R1 : 10~200Ω 1/4W min..
 C1 : 0.1~0.33μF
 AC125V(INPUT 110V)
 AC250V(INPUT 220V)
 R2 : 5.6Ω 10W

- When switch from “RUN” to “STOP”, electric brake acts for approx. 0.5sec and motor stops instantaneously.
- During this period, do not operate switch SW4 SW5
- Switching of SW4 SW5 should be earlier than switching of SW2 SW3 from STOP to RUN.

⑥ REVERSIBLE(正·逆運轉) + VARIABLE SPEED(變速 + 制動) 40w~120W

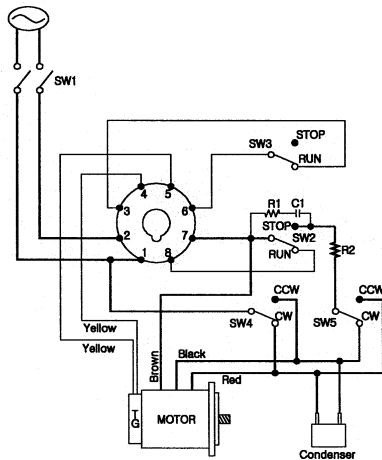

- * 1 RUN 에서 STOP 으로하면 제동(전기BRAKE)가 약 0.5초간 작동하여 MOTOR가 순시정지합니다
- 2 이 0.5초동안은 SW4, SW5를 조작하지 마십시오
- 3 SW4, SW5의 절차는 SW2, SW3의 STOP에서 RUN의 절체보다 빨리 하십시오.

SW1 SW2 : AC125V OR AC250V 5A
 SW3 : DC 10V 10mA
 SW4 SW5 : AC125V OR AC250V 5A
 R1 : 10~200Ω 1/4W이상
 C1 : 0.1~0.33μF
 AC125V(INPUT 110V)
 AC250V(INPUT 220V)
 R2 : 5.6Ω 10W

- When switch from “RUN” to “STOP”, electric brake acts for approx. 0.5sec and motor stops instantaneously.
- During this period, do not operate switch SW4 SW5
- Switching of SW4 SW5 should be earlier than switching of SW2 SW3 from STOP to RUN.

◎ EXTERNAL SPEED SETTING(外部速度設定)

REMOTE SPEED CONTROL(遠隔操作)

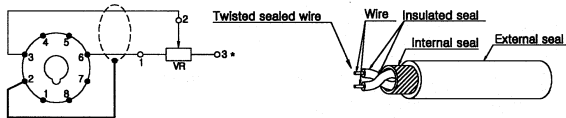

- * 1 본체의 속도설정기는 “0” 에 설정하십시오
- 2 배선은 될수 있는한 짧게 하십시오
 TWIST된 SHIELD선을사용하시고
 SHIELD부를 SOCKET의 2번 단자에 접속하십시오.

VR : SPEED SETTING RESISTOR 20kΩ TYPE B 1/4W

- Set the built-in speed setting knob to “0”.
- Recommend twisted shield wire and grounding this shield to socket terminal No.2.

MULTI-STEP SPEED SETTING(多段階速度設定)

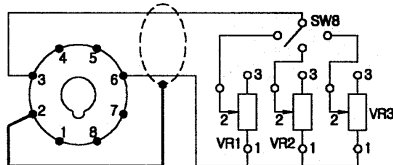

VR1, VR2, VR3 : 20kΩ 1/4W TYPE B
 SW3 : DC 10V 1mA

- * 1 본체의 속도설정기는 0에 설정하십시오
- 2 외부속도설정기 VR1, VR2, VR3 로 각각의 속도를 설정하고 SWITCH SW8로 절체하십시오.

- Set the built-in speed setting knob to “0”.and external resistor VR1, VR2, VR3 to multi-step speed.
- Recommend twisted shield wire and grounding this shield to socket terminal No.2.

⑦ REVERSIBLE (正 · 逆運轉) + VARIABLE SPEED (變速) + BRAKE (制動)

CONTROLLER의 전기 BRAKE는 사용안할때 * 6w~120w

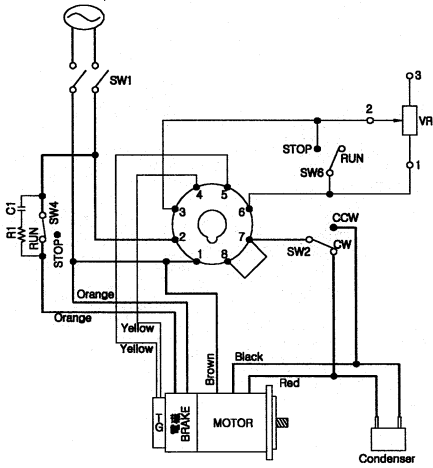

- 1 정지시간을 설정하여 회전이 정지한후 SW2를 절체하십시오.
- 2 전원SWITCH SW1의 투입시간은 SW4, SW6에 의한 운전개시 신호보다 약 0.5초 빠르게 하십시오.
- 3 운전-정지의 조작을 할때는 SW1을 "ON"으로 두고 SW4, SW6로 조작하십시오. 장시간 정지시킬때는 SW1을 끊어 주십시오.

| | |
|---------------|---|
| SW1, SW2, SW4 | : AC125V or AC250V 5A |
| SW6 | : DC 10V 10mA |
| R1 | : 10~200Ω 1/4W min |
| C1 | : 0.1~0.33μF AC125V(INPUT 110V) AC250V(INPUT 220V) |
| VR | : 20kΩ 1/W TYPE B |

- Electric brake of control unit is NOT USED simultaneously.
- Operate SW2 after motor stops completely.
- Closing of switch SW1 should be 0.5sec earlier than starting signal of SW4 and SW6.
- Switching for START-STOP should be done by switch SW4 and SW6 leaving switch SW1 as "ON".

⑦ REVERSIBLE (正 · 逆運轉) + VARIABLE SPEED (變速) + BRAKE (制動)

CONTROLLER의 전기 BRAKE를 사용할때 * 6w~25w

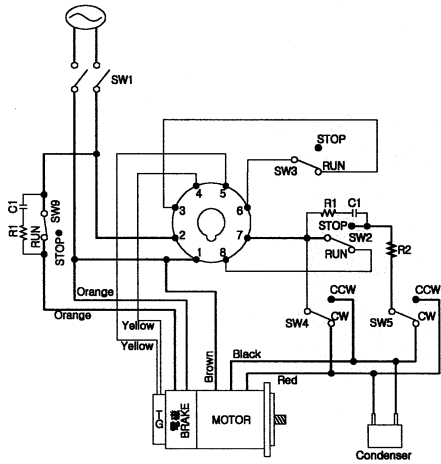

- 1 "RUN"으로부터 "STOP"으로 하면 제동(전기BRAKE)이 동작하여 MOTOR가 급정지합니다.
- 2 MOTOR가 정지한후 SW4, SW5를 조작하십시오
- 3 SW4, SW5의 절체는 SW2, SW3, SW9의 "STOP"으로부터 "RUN"에의 절체보다 빠르게 하십시오
- 4 전원 SWITCH SW1투입의 시간은 SW2, SW3, SW9에의한 운전시동의 신호보다 약 0.5초이상 빠르게 하십시오
- 5 운전-정지의 조작을 할때는 SW1을 "ON"으로 두고 SW2, SW3, SW9로 조작하십시오. 장시간 정지시킬때는 SW1을 끊어 주십시오.

| | |
|---------------|---|
| SW1, SW2, SW9 | : AC125V or AC250V 5A |
| SW4, SW5 | : DC 10V 10mA |
| SW3 | : DC 10V 10mA |
| R2 | : 5.6Ω 10W |
| R1 | : 10~200Ω 1/4W min |
| C1 | : 0.1~0.33μF AC125V(input 110V) AC250V(input 220V) |
| VR | : 20kΩ 1/W type B |

- Electric brake of control unit is USED simultaneously.
- When switch from "RUN" to "STOP", electric brake acts and motor stops instantaneously.
- Operate SW4 SW5 after motor stops completely.
- Switching of switch SW4 and SW5 should be earlier than switching of SW2 SW3 SW9 from "STOP" to "RUN".
- Closing of switch SW1 should be 0.5sec earlier than starting signal of SW2, SW3 and SW9.
- Switching for START-STOP should be done by switch SW2, SW3 and SW9 leaving switch SW1 as "ON".

40w~120w

